

PART NUMBER	REV	DESCRIPTION
2430648-1	1	Mini Applicator - LP
7-2430648-1	1	Mini Applicator - LP w/spare parts Kit
7-2430648-7	1	Applicator Kit

CRIMP DATA		
TERMINAL DESCRIPTION [HSD 0.5MMM2]		
WIRE ADJUSTMENT DISC POSITION	CRIMP HEIGHT	WIRE SIZE
-	-	4X0.5mm ²
WIRE STRIP LENGTH		TERMINAL APPLICATION SPECIFICATION 114-94396
CRIMPER	CRIMP WIDTH	CRIMPER PROFILE
CLINCHER?	x.xx mm (.xyz in)	x
INSULATION RANGE	WIRE RANGE	GAUGE
5.80 - 6.20 mm	-	1707132-1
TERMINALS APPLIED:		
SHIELDING ASM	PROTECTIVE COVER	
2294477-1	2294473-1	

- NOTES:
- ① RECOMMENDED SPARE PARTS
 - ② GREASE BEARING SURFACES LIGHTLY
 - ③ MAGNET, ITEM 45, MUST BE ORIENTED CORRECTLY IN ORDER TO PROPERLY ACTUATE THE COUNTER.
 - 4. UNLESS SPECIFIED OTHERWISE TORQUE VALUES SHALL BE USED PER DOCUMENT, 101-35000.
 - 5. APPLICATOR TO BE USED ON BENCH TERMINATORS ONLY.
 - 6. RECOMMENDED TERMINATORS:
G11 TERMINATOR FOR LOOSE PIECE APPLICATORS PN 2374600-1 OR 2374600-2 (W/ COM).
G11+ TERMINATOR FOR LOOSE PIECE APPLICATORS PN 2844810-1 OR 2844810-2 (W/ COM).
 - ④ WHEN WORKING IN THE G11 OR G11+ TERMINATOR THE INSTALLATION OF MICROSWITCH ITEM #46 IS NOT NEEDED. THE INSTALLATION OF THE MICROSWITCH IS MANDATORY ONLY FOR OTHER TERMINATORS.

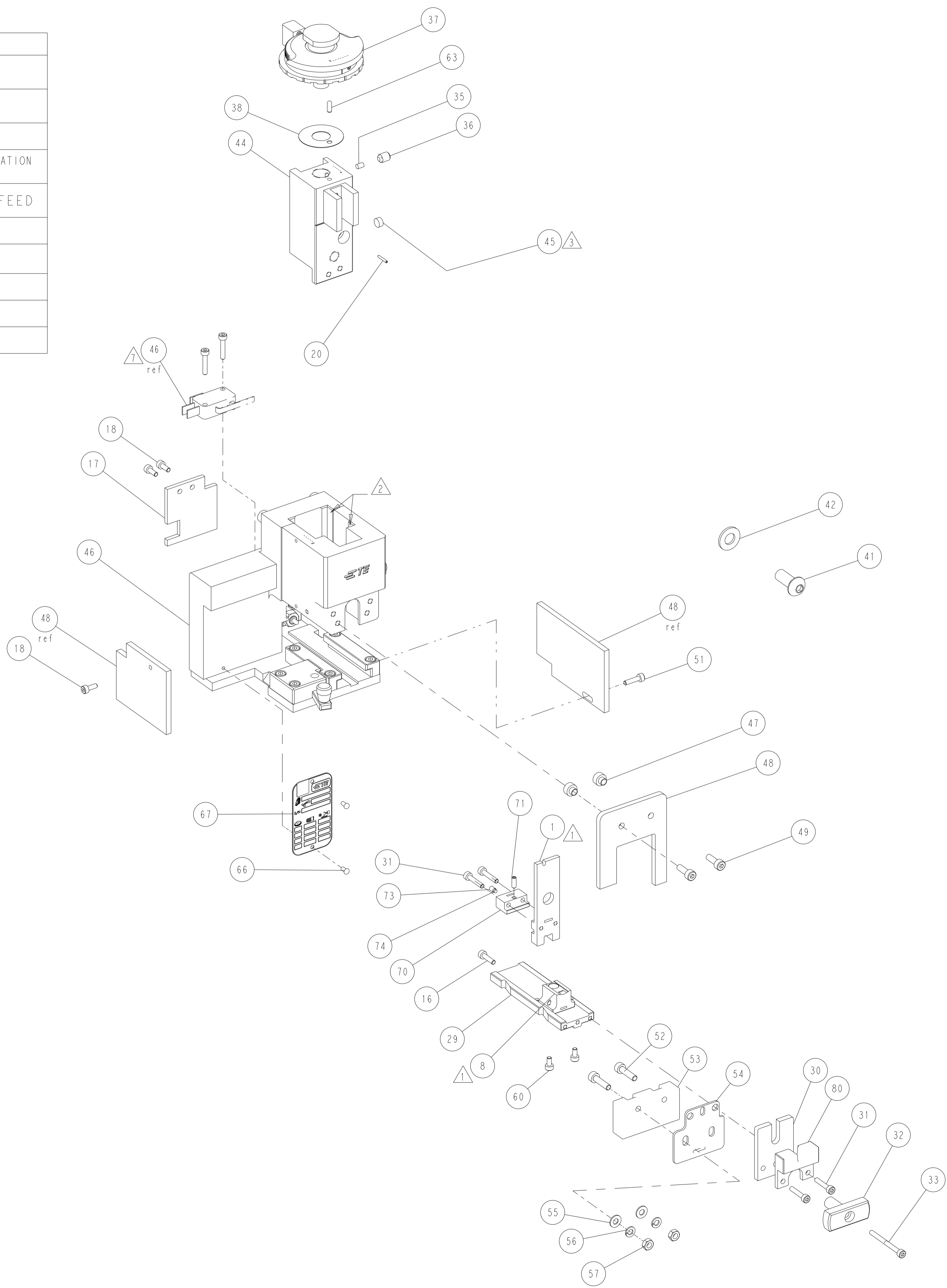

REVISIONS				
P	LTN	DESCRIPTION	DATE	APVD
1		DEVELOPMENT	29SEP2022	LS GS

-	1	1	2415445-1	CABLE CLAMP	80
-	1	1	690191-6	PLUG, NYLON	74
-	1	1	18032-1	SCR, SET, FLT PNT, M3 X 5.0	73
-	1	1	2168468-4	PLUNGER, SPRING, INTERNAL HEX, HI	71
-	1	1	2432170-1	SPACER, TONKER	70
-	1	1	2119740-1	TAG, IDENTIFICATION	67
-	2	2	2168078-1	SCREW, DRIVE, RH, RoHS, 2 x .188	66
-	1	1	1-992946-4	PIN, DOWEL 3 X 8	63
-	2	2	18023-2	SCR, SKT HD CAP M3 X 6.0	60
-	2	2	5018030-2	NUT, HEX, REG, RoHS, M4	57
-	2	2	1-18026-0	WASHER, SPRG LOCK, REG M4	56
-	2	2	1-18028-2	WASHER, FLAT, REG M4	55
-	1	1	2844821-1	BRACKET, ACTUATOR, MINI-SIZE	54
-	1	1	2168489-1	ACTUATOR, SPARE, MC1	53
-	2	2	2168083-8	SCR, SKT HD CAP, RoHS, M4 X 16	52
-	1	1	18023-5	SCR, SKT HD CAP M3 X 12.0	51
-	2	2	1-18023-2	SCR, SKT HD CAP M4 X 12.0	49
-	1	1	1707831-7	APPLICATOR GUARD	48
-	2	2	1707368-1	SPACER, APPL. GUARD	47
-	1	1	2077852-1	APPLICATOR BASIC ASSEMBLY, MINI-LP	46
-	1	1	994969-1	MAGNET, RARE EARTH, HIGH ENERGY	45
-	1	1	1707115-1	RAM, MINI APPLICATOR	44
-	1	1	1-18028-0	WASHER, FLAT, REG M8	42
-	1	1	2-18024-5	SCR, BTN SKT HD CAP (M8 X 20.0)	41
-	1	1	1707150-1	WASHER, FLAT	38
-	1	1	2077830-1	WIRE DISC, FINE ADJUST.	37
-	1	1	18032-8	SCR, SET, FLT PNT, M6 X 8.0	36
-	1	1	690191-1	PLUG, NYLON	35
-	1	1	9-18023-4	SCR, SKT HD CAP M3 X 35.0	33
-	1	1	1707779-1	KNOB	32
-	4	4	18023-6	SCR, SKT HD CAP M3 X 16.0	31
-	1	1	1-624887-1	APPLICATOR GUARD	30
-	1	1	1707825-7	GUIDE BLOCK	29
-	1	1	1-9931111-0	PIN, SLOTTED SPRING 1.5 X 10.0	20
-	3	3	18023-3	SCR, SKT HD CAP M3 X 8.0	18
-	1	1	2076888-1	REAR APPLICATOR GUARD	17
-	1	1	18023-5	SCR, SKT HD CAP M3 X 12.0	16
①	1	2	2430425-1	SPECIAL ANVIL, MINI LP	8
①	1	2	2430426-1	SPECIAL CRIMPER, MINI LP	1
-	77	-71	-1	PART NO	ITEM NO

THIS DRAWING IS A CONTROLLED DOCUMENT.		OWN L. SANDHU 29SEP2022	TE Connectivity	
DIMENSIONS:		CHK L. SANDHU 29SEP2022	NAME LOOSE PIECE MINI APPLICATOR	
TOLERANCES UNLESS OTHERWISE SPECIFIED:		APVD G. STEGMAYER 29SEP2022	SIZE A	
MATERIAL TBD		PRODUCT SPEC	SCALE 3:5	
WEIGHT		APPLICATION SPEC	SHEET 1 OF 1	
CUSTOMER ACCESSIBLE PRODUCTION DRAWING		RESTRICTED TO	REV 1	

单击下面可查看定价，库存，交付和生命周期等信息

[>>TE Connectivity\(泰科\)](#)