

4

3

2

1

This drawing involves proprietary design rights of Tyco Electronics Corporation, and all design, manufacture, reproduction, use and sale rights regarding the same are expressly reserved. It is submitted for a specific purpose and the recipient by accepting this drawing, assumes custody and control and agrees to take reasonable precautions: (a) that this drawing will not be copied and reproduced, in whole or in part, or its contents revealed in any manner, or to any person except to meet the purpose for which it was delivered and (b) that any special features peculiar to this design will not be incorporated in other projects without the expressed written permission of Tyco Electronics Corporation.

| REVISIONS | | | |
|-----------|-----|-------------|----------|
| EC | REV | DESCRIPTION | DATE |
| CPR | A | NEW RELEASE | 05/30/06 |

NOTES: UNLESS OTHERWISE SPECIFIED;

1. PART NUMBER CHANGES AND OR DESIGN CHANGES AFFECTING ITEM INTERCHANGEABILITY REQUIRE PRIOR TYCO APPROVAL AND AUTHORIZATION BY REVISION TO THIS DRAWING.

2. MATERIALS:

INSULATORS: THERMOPLASTIC, GLASS REINFORCED, COLOR-BLACK UL94V-0 FLAMMABILITY RATED.

COMPLIANT PRESS FIT: COPPER ALLOY

3. FINISHES:

CONTACTS: SELECTIVE GOLD PLATED, .000030" MIN THICK OVER NICKEL PLATED, .000050" MIN THICK.

TERMINALS: TIN PLATED, .000040" MIN THICK OVER NICKEL PLATED, .000050" MIN THICK.

4. ITEMS PROVIDED TO THIS SPECIFICATION TO BE PERMANENTLY IDENTIFIED PER THE FOLLOWING IDENTIFIER:

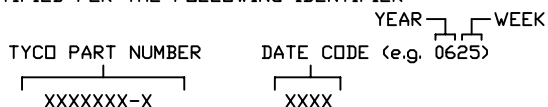



5. CONNECTOR INFORMATION

| CONNECTOR | CONTACT | QTY | PIN/BLADE SIZE | MAX CURRENT (PER CONTACT) | CONTACT SPACING | VOLTAGE RATING* |
|-----------|------------|-----|------------------------------|---------------------------|-----------------|-----------------|
| SOCKET | DC POWER 1 | 3 | 1.25 X 7.00 [.049 X .276] | 35 AMPERES | 4.50 [1.771] | 125 VOLTS |

*IAW IEC-950

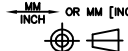
| | |
|-------------|-------------|
| 1766976-1 | AS SHOWN |
| PART NUMBER | DESCRIPTION |

| | | | | |
|--|---|---------------------------------|---|---|
|  <small>THIRD ANGLE PROJECTION</small> <small>UNLESS OTHERWISE SPECIFIED DIMENSIONS ARE IN METRIC [INCHES]</small> <small>TOLERANCES</small> <small>ANGLES ± .5°</small> <small>DECIMALS</small> <small>.XX ± .25 [.010]</small> <small>.X ± .5 [.020]</small> | <small>DRAWN</small> R. F. A. | <small>DATE</small> 11/15/05 |  Tyco Electronics Corporation Menlo Park, Ca 94025  | |
| | <small>CHECKED</small> | | | <small>TITLE</small> CONNECTOR, SOCKET STRAIGHT, COMPLIANT PRESS FIT MINIPAK |
| | <small>APPROVED</small> STEVE FLICKINGER | 05/30/06 | | <small>SIZE</small> B |
| | <small>DCA APPROVED</small> HA NGUYEN | 05/30/06 | | <small>DWG NUMBER</small> C = 1766976 |
| <small>ACAD FILE NUMBER</small> C1766976A.DWG | <small>DWG SCALE</small> 2=1 | <small>SH</small> 1 OF 3 | <small>REV.</small> A | |

4

3

2

1

This drawing involves proprietary design rights of Tyco Electronics Corporation, and all design, manufacture, reproduction, use and sale rights regarding the same are expressly reserved. It is submitted for a specific purpose and the recipient by accepting this drawing, assumes custody and control and agrees to take reasonable precautions: (a) that this drawing will not be copied and reproduced, in whole or in part, or its contents revealed in any manner, or to any person except to meet the purpose for which it was delivered and (b) that any special features peculiar to this design will not be incorporated in other projects without the expressed written permission of Tyco Electronics Corporation.

| REVISIONS | | | |
|-----------|-----|-------------|------|
| EC | REV | DESCRIPTION | DATE |
| | | SEE SHEET 1 | |

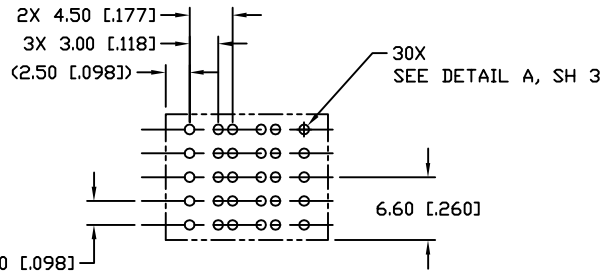
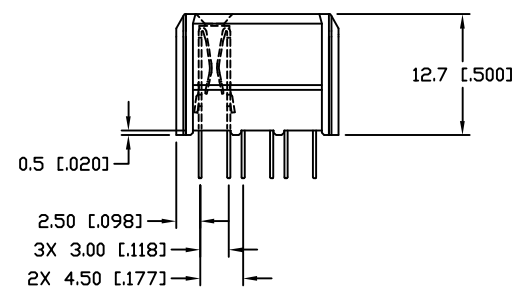
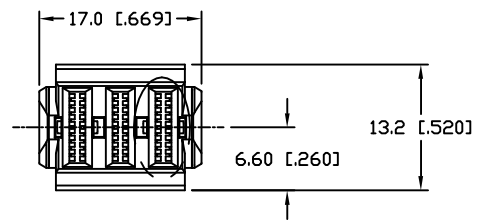
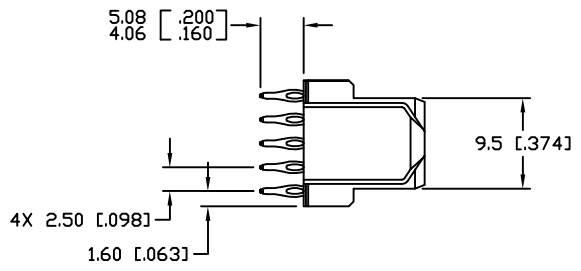

PRINTED CIRCUIT BOARD LAYOUT

| | | | | |
|--|--|---|--|--|
| <small>MM OR MM [INCH]</small> <small>INCH</small> <small>THIRD ANGLE PROJECTION</small> <small>UNLESS OTHERWISE SPECIFIED DIMENSIONS ARE IN METRIC [INCHES]</small> <small>TOLERANCES</small> <small>ANGLES ± .5°</small> <small>DECIMALS</small> <small>.XX ± .25 [.010]</small> <small>.X ± .5 [.020]</small> | <small>DRAWN</small> R. F. A. | <small>DATE</small> 11/15/05 | Tyco Electronics Corporation Menlo Park, Ca 94025 | |
| | <small>CHECKED</small> | <small>TITLE</small> CONNECTOR, SOCKET STRAIGHT, COMPLIANT PRESS FIT MINIPAK | | |
| | <small>APPROVED</small> STEVE FLICKINGER | <small>DATE</small> 05/30/06 | <small>SIZE</small> B | <small>DWG NUMBER</small> C = 1766976 |
| | <small>APPROVED</small> DCA APPROVED HA NGUYEN | <small>DATE</small> 05/30/06 | <small>REV.</small> A | <small>ACAD FILE NUMBER</small> C1766976A.DWG |
| <small>DWG SCALE</small> 2=1 | | | <small>SH</small> 2 OF 3 | |

This drawing involves proprietary design rights of Tyco Electronics Corporation, and all design, manufacture, reproduction, use and sale rights regarding the same are expressly reserved. It is submitted for a specific purpose and the recipient by accepting this drawing, assumes custody and control and agrees to take reasonable precautions: (a) that this drawing will not be copied and reproduced, in whole or in part, or its contents revealed in any manner, or to any person except to meet the purpose for which it was delivered and (b) that any special features peculiar to this design will not be incorporated in other projects without the expressed written permission of Tyco Electronics Corporation.

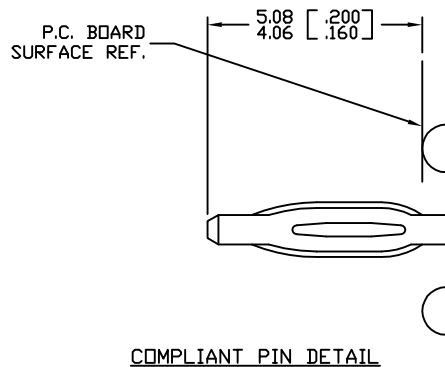

COMPLIANT PIN DETAIL
 SCALE: 10 : 1
 INSERTION/EXTRACTION FORCES
 MAXIMUM PUSH IN: 133.3N PER PIN [30 LBS]
 MINIMUM PUSH OUT: 44.4N PER PIN [10 LBS]

| REVISIONS | | | |
|-----------|-----|-------------|------|
| EC | REV | DESCRIPTION | DATE |
| | | SEE SHEET 1 | |

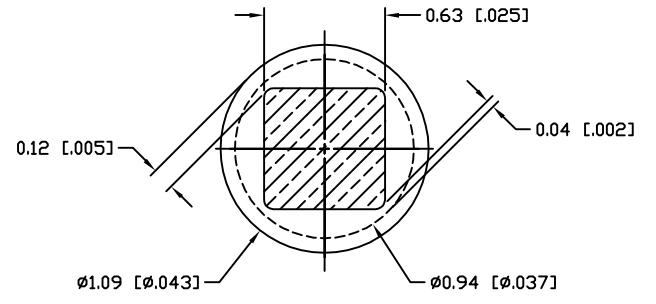

SOLDER TERMINATION AREA
 SCALE: 40 : 1
 RECOMMENDED PRINTED CIRCUIT HOLE
 COMPLIANT PRESS FIT
 DRILLED HOLE: $\phi 1.15 \pm 0.013$ [$\phi 0.0453 \pm 0.0005$]
 COPPER PLATE: 0.025 [0.0010] - 0.050 [0.0020]
 TIN PLATE: .0005 [0.00002] MINIMUM (PER SURFACE)

DETAIL A

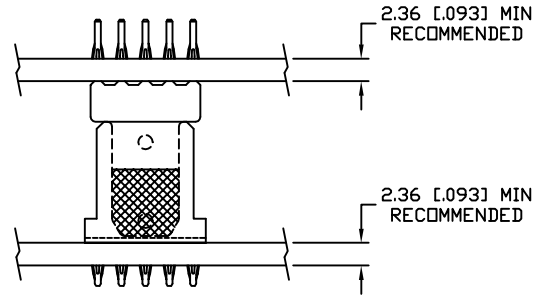

MATED CONDITION

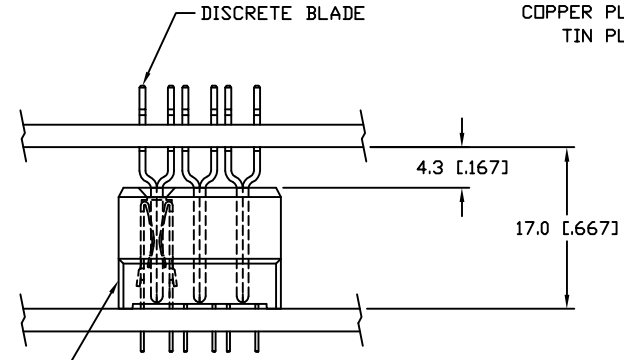

SOCKET CONNECTOR
1766976-1

| | | | | | |
|---|---------------------------------------|---|--|---------------------------|-----------|
| UNLESS OTHERWISE SPECIFIED DIMENSIONS ARE IN METRIC [INCHES] TOLERANCES ANGLES $\pm .5^\circ$ DECIMALS .XX $\pm .25$ [.010] .X $\pm .5$ [.020] | DRAWN R. F. A. | DATE 11/15/05 | Tyco Electronics Corporation Menlo Park, Ca 94025 | | |
| | CHECKED | TITLE USER INFORMATION COMPLIANT TAIL TERMINATION AND MATED CONDITION | | | |
| | APPROVED STEVE FLICKINGER | DATE 05/30/06 | SIZE B | DWG NUMBER C = 1766976 | REV. A |
| | APPROVED DCA APPROVED HA NGUYEN | DATE 05/30/06 | ACAD FILE NUMBER C1766976A.DWG | DWG SCALE 2=1 | SH 3 OF 3 |

单击下面可查看定价，库存，交付和生命周期等信息

[>>TE Connectivity\(泰科\)](#)