

THIS DRAWING IS UNPUBLISHED.
VERTRAULICHE UNVEROFFENTLICHTE ZEICHNUNG

RELEASED FOR PUBLICATION
FREI FUER VEROFFENTLICHUNG

MATED WITH:
PASSEND ZU:

LOC
A1

DIST
-

REVISIONS
AENDERUNGEN

© COPYRIGHT 2011

ALL RIGHTS RESERVED.
ALLE RECHTE VORBEHALTEN.

PROJEKT NR.:

P

LTR

DESCRIPTION
BESCHREIBUNG

DATE

DWN

APVD

E PLATING ADJUSTED

23JUL2013 TSA DWE

E1 NOTE 7 ADDED

22MAR2018 SGS FW I

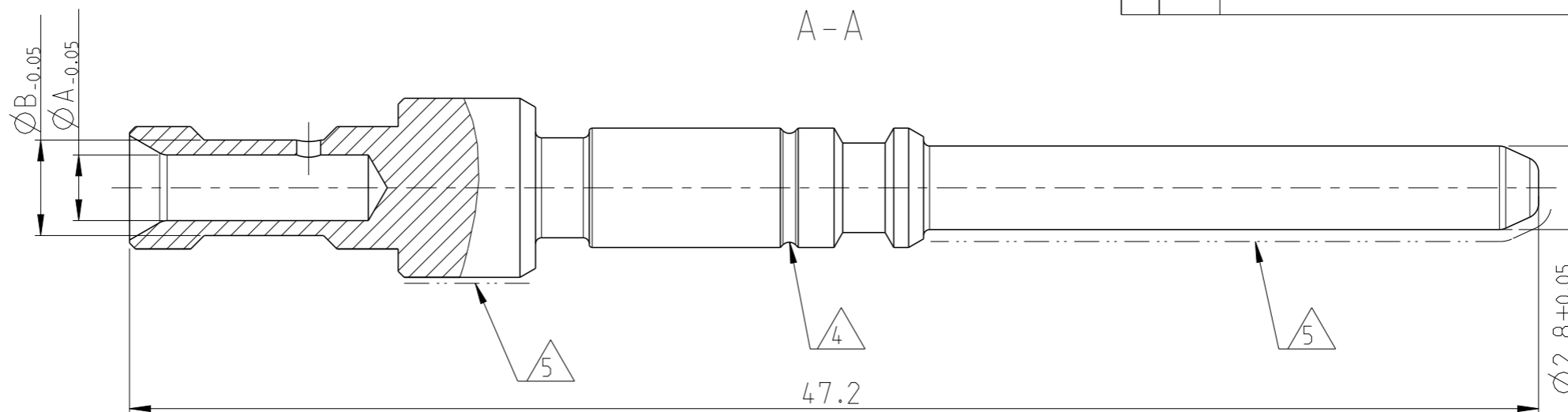
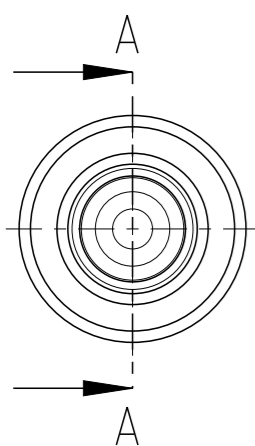

NOTES
Bemerkungen

- 1 IN CASE OF DISCREPANCIES BETWEEN GERMAN AND ENGLISH TEXT THE GERMAN TEXT IS BINDING
Im Falle von Unterschieden zwischen dem deutschen und dem englischen Text ist der deutsche Text verbindlich
- 2 MAX ALLOWABLE PARTICLE SIZE ACC. VDA BAND 19: 0.5mm
Max. zulaessige Partikelgroesse gemass VDA Band 19: 0.5mm
- 4 CROSS SECTION MARKING:
NUMBER OF GROOVES ACC. TABLE
Leitungsquerschnitt Kennzeichnung:
Anzahl Einschnitte gemass Tabelle
- 5 CONTACT AREA
Kontaktierflaeche
- 6 BULK PACKAGING IN PLASTIC BAG IN FOLDING CARTON
PN 0-973171-1 AND CORRUGATED SHIPPING BOX PN 0-973058-3
Schuetzguet in Beutel in Faltschachtel PN 0-973171-1 und
Versandkarton PN 0-973058-3
- 7 ALTERNATE CRIMP FOR 3mm² CONDUCTOR-DMC CRIMP PER
WE-20160346ACL
Alternativ Crimp fuer 3mm² Leiter DMC CRIMP PER
WE-20160346ACL

PART NUMBERS	REV	[mm ²]	MARKING	DIMENSIONS		MATERIAL	SURFACE/ COLOR
				A	B		
9-2177817-3	E	6	3	3.4	4.8	BRASS	SILVER
9-2177817-2	E	4	2	2.85	3.9		
9-2177817-1	E	2.5	1	2.2	3.2		

2:1

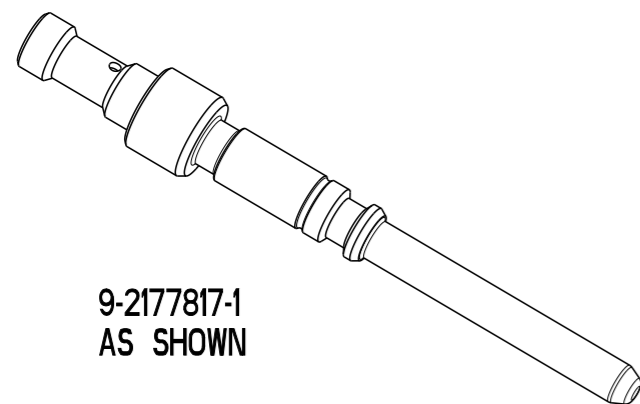

DIESE ZEICHNUNG IST EIN KONTROLLIERTES DOKUMENT.
BEMASSUNGEN UND TOLERANZEN GEMAESS GPS (ISO STANDARDS).

THIS DRAWING IS A CONTROLLED DOCUMENT.
DIMENSIONING AND TOLERANCING PER GPS (ISO STANDARDS).

DIMENSIONS: MASSEINHEITEN: mm	TOLERANCES UNLESS OTHERWISE SPECIFIED: ALLGEMEINTOLERANZEN	DWN Vishwa A 13MAR2012
	0 PLC ± DIN ISO 1 PLC ± 2768-fH 2 PLC ± 3 PLC ± 4 PLC ± ANGLES/WINKEL ±	CHK F. Wittrock 02APR2012
MATERIAL	FINISH/OBERFLAECHE/FARBE	APVD D. Weyrauch 04APR2012
-	-	PRODUCT SPEC PRODUKTSPEZ. -
-	-	APPLICATION SPEC VERARBEITUNGSSPEZ. -
-	-	WEIGHT GEWICHT 3g



NAME
PIN CONTACT, DIA2.8, PE
Rundkontakt, 2,8mm, PE

SIZE A3 CAGE CODE 00779 DRAWING NO. ZEICHNUNGS-NR. C=2177817 RESTRICTED TO NUR FUER

CUSTOMER DRAWING /KUNDENZEICHNUNG SCALE MASSSTAB: 5:1 SHEET BLATT 1 OF VON 1 REV E1

单击下面可查看定价，库存，交付和生命周期等信息

[>>TE Connectivity\(泰科\)](#)