

THIS DRAWING IS UNPUBLISHED. RELEASED FOR PUBLICATION
 © COPYRIGHT BY TYCO ELECTRONICS CORPORATION. ALL RIGHTS RESERVED.

LOC	DIST	REVISIONS			
P	LTR	DESCRIPTION	DATE	DWN	APVD
FT	0	A1	REVISED PER ECO-05-8197	8/30/05	SS CR

MATERIAL:
 HOUSING: POLYAMIDE 6/6, WHITE.
 TRACKING RESISTANCE PTI 600.
 SCREWS: STEEL, ZINC PLATED.
 CONDUCTOR SIZE: $\phi 5.5-11.0\text{mm}$.

ENVIRONMENTAL:
 CONTINUOUS WORKING TEMP.: 100°C.
 SHORT TIME TEMP.: 160°C.

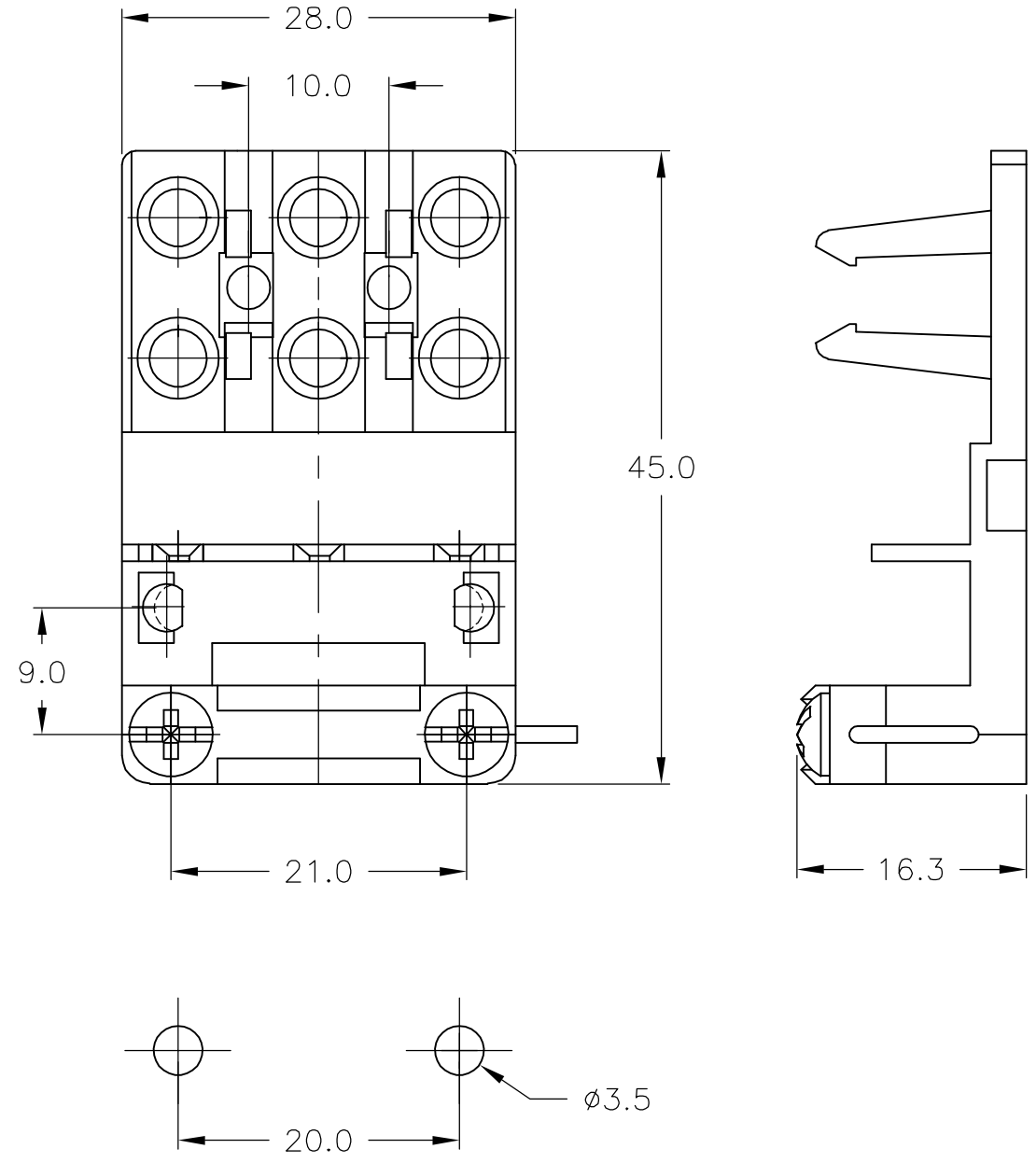

HOLE PATTERN

1546182-2
 PART NUMBER

THIS DRAWING IS A CONTROLLED DOCUMENT.		DWN S SCHLEGEL	30AUG05	 Tyco Electronics Corporation Harrisburg, Pa 17105-3608
DIMENSIONS: mm		CHK C RICHARD	8/30/05	
		APVD C RICHARD	8/30/05	
TOLERANCES UNLESS OTHERWISE SPECIFIED:		PRODUCT SPEC		NAME STRAIN RELIEF TYPE 500 ZEL RZ
0 PLC ± - 1 PLC ± - 2 PLC ± - 3 PLC ± - 4 PLC ± - ANGLES ± -		APPLICATION SPEC		SIZE A3
MATERIAL		WEIGHT		CAGE CODE 00779
FINISH		CUSTOMER DRAWING		DRAWING NO 1546182
		SCALE NTS		RESTRICTED TO -
		SHEET 1 OF 1		REV A1

单击下面可查看定价，库存，交付和生命周期等信息

[>>TE Connectivity\(泰科\)](#)