

- $\triangle 1$  HOUSING: LIQUID CRYSTAL POLYMER, COLOR BLACK.  
CONTACTS: HIGH RELIABILITY COPPER ALLOY.  
GROUND BUSES: PHOSPHOR BRONZE ALLOY, UNS C51100.
- $\triangle 2$  CONTACTS & GROUND BUSES: NICKEL UNDERPLATE ALL OVER,  
MATING SURFACE PLATED TO MEET LEVEL 1 PERFORMANCE  
REQUIREMENTS OF TE PRODUCT SPECIFICATION 108-1422,  
SOLDER TAILS PLATED MATTE TIN.
- $\triangle 3$  DATE CODE MARKED IN AREA INDICATED ON SIDE OPPOSITE  
POSITION #1.
- $\triangle 4$  ONE GROUND BUS WITH 5 TAILS PER EACH MODULE.
- $\triangle 5$  TOLERANCE NON-ACCUMULATIVE.
- $\triangle 6$  FOR STANDARD APPLICATIONS, ORIENTATION HOLE TO BE  
 $\phi .094 \pm .002 [2.39 \pm 0.05]$ .  
FOR SLIP-FIT APPLICATIONS, ORIENTATION HOLE TO BE  
 $\phi .079 \pm .001 [2.00 \pm 0.03]$ .
- $\triangle 7$  OBSOLETE

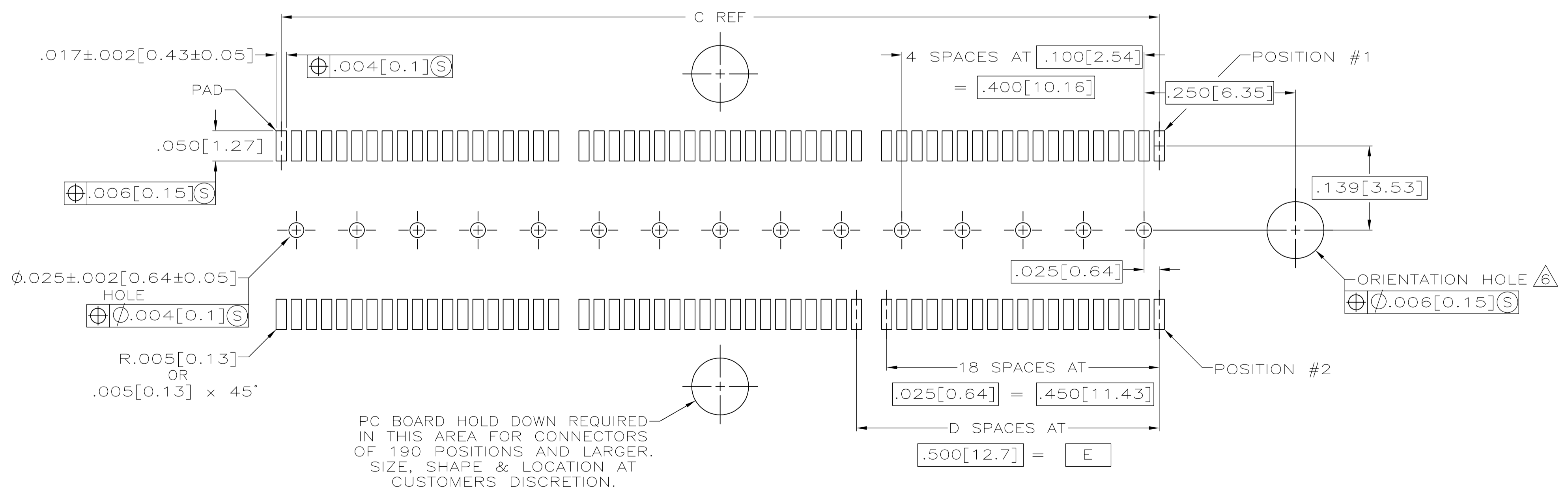
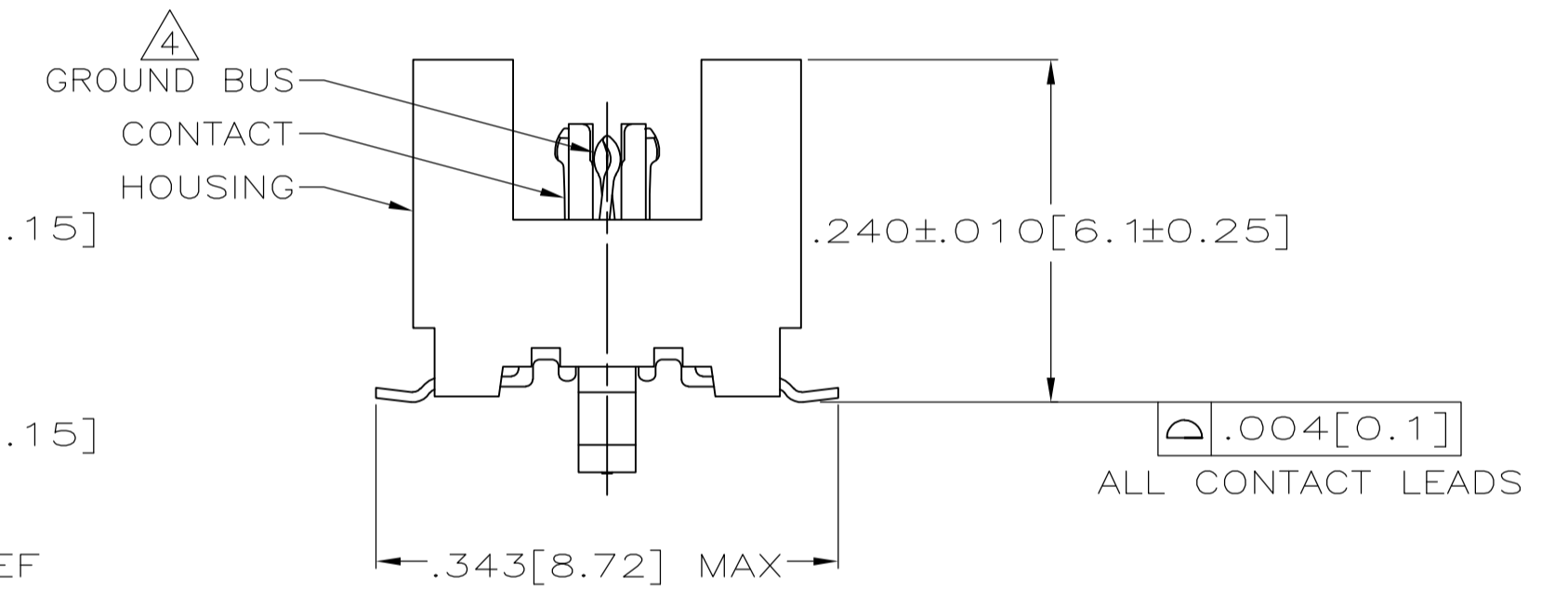
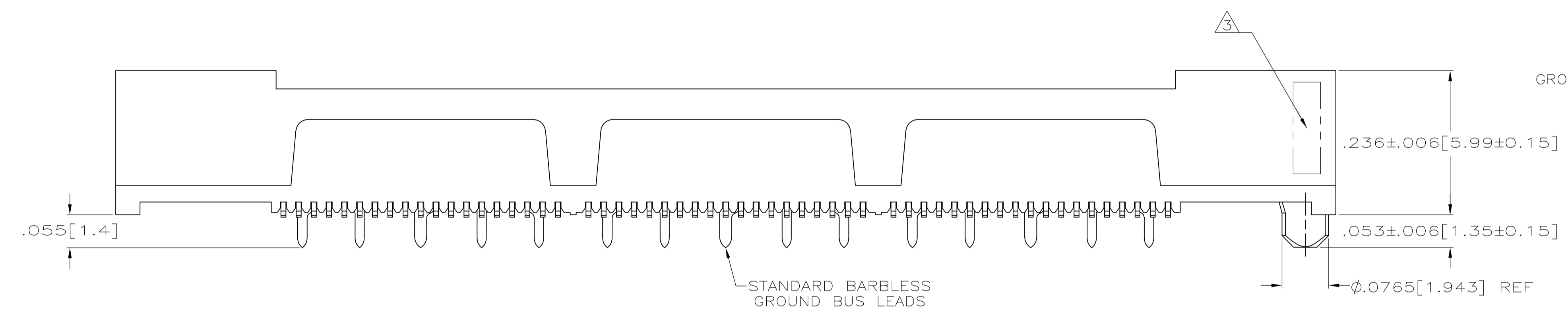

PC BOARD HOLD DOWN REQUIRED  
IN THIS AREA FOR CONNECTORS  
OF 190 POSITIONS AND LARGER.  
SIZE, SHAPE & LOCATION AT  
CUSTOMERS DISCRETION.

RECOMMENDED PC BOARD LAYOUT  
(VIEWED FROM CONNECTOR SIDE)

4.724 [120]	3.000 [76.2]	6	3.450 [87.63]	3.900 [99.06]	4.000 [101.6]	266	5767110-7
4.094 [104]	2.500 [63.5]	5	2.950 [74.93]	3.400 [86.36]	3.500 [88.9]	228	5767110-6
3.465 [88]	2.000 [50.8]	4	2.450 [62.23]	2.900 [73.66]	3.000 [76.2]	190	5767110-5
3.465 [88]	1.500 [38.1]	3	1.950 [49.53]	2.400 [60.96]	2.500 [63.5]	152	5767110-4
2.835 [72]	1.000 [25.4]	2	1.450 [36.83]	1.900 [48.26]	2.000 [50.8]	114	5767110-3
2.205 [56]	.500 [12.7]	1	.950 [24.13]	1.400 [35.56]	1.500 [38.1]	76	5767110-2
1.732 [44]	.000 [0]	0	.450 [11.43]	.900 [22.86]	1.000 [25.4]	38	5767110-1
F	E	D	C	B	A	NO OF POS	PART NUMBER

THIS DRAWING IS A CONTROLLED DOCUMENT.

DIMENSIONS: INCHES	TOLERANCES UNLESS OTHERWISE SPECIFIED:	DWN: S. ATTADIA 27 OCT 04	CHK: D. DIXON 27 OCT 04	APVD: D. DIXON 27 OCT 04	NAME: Tyco Electronics Corporation Harrisburg, Pa 17105-3608
0 PLC ± -	1 PLC ± -	2 PLC ± -	3 PLC ± .005 [0.13]	4 PLC ± -	ANGLES ± -
MATERIAL: $\triangle 1$	FINISH: $\triangle 2$	PRODUCT SPEC: 108-1422	APPLICATION SPEC: 114-11004	SIZE: A1	CAGE CODE: 000779
CUSTOMER DRAWING		SCALE: 8:1	SHEET: 1 OF 1	REV: B	RESTRICTED TO: -

单击下面可查看定价，库存，交付和生命周期等信息

[>>TE Connectivity\(泰科\)](#)