

LOC	DIST	REVISIONS					
GP	00	P	LTN	DESCRIPTION	DATE	DWN	APVD
		A		PROMOTED TO PRODUCTION	04NOV2016	TX	SH

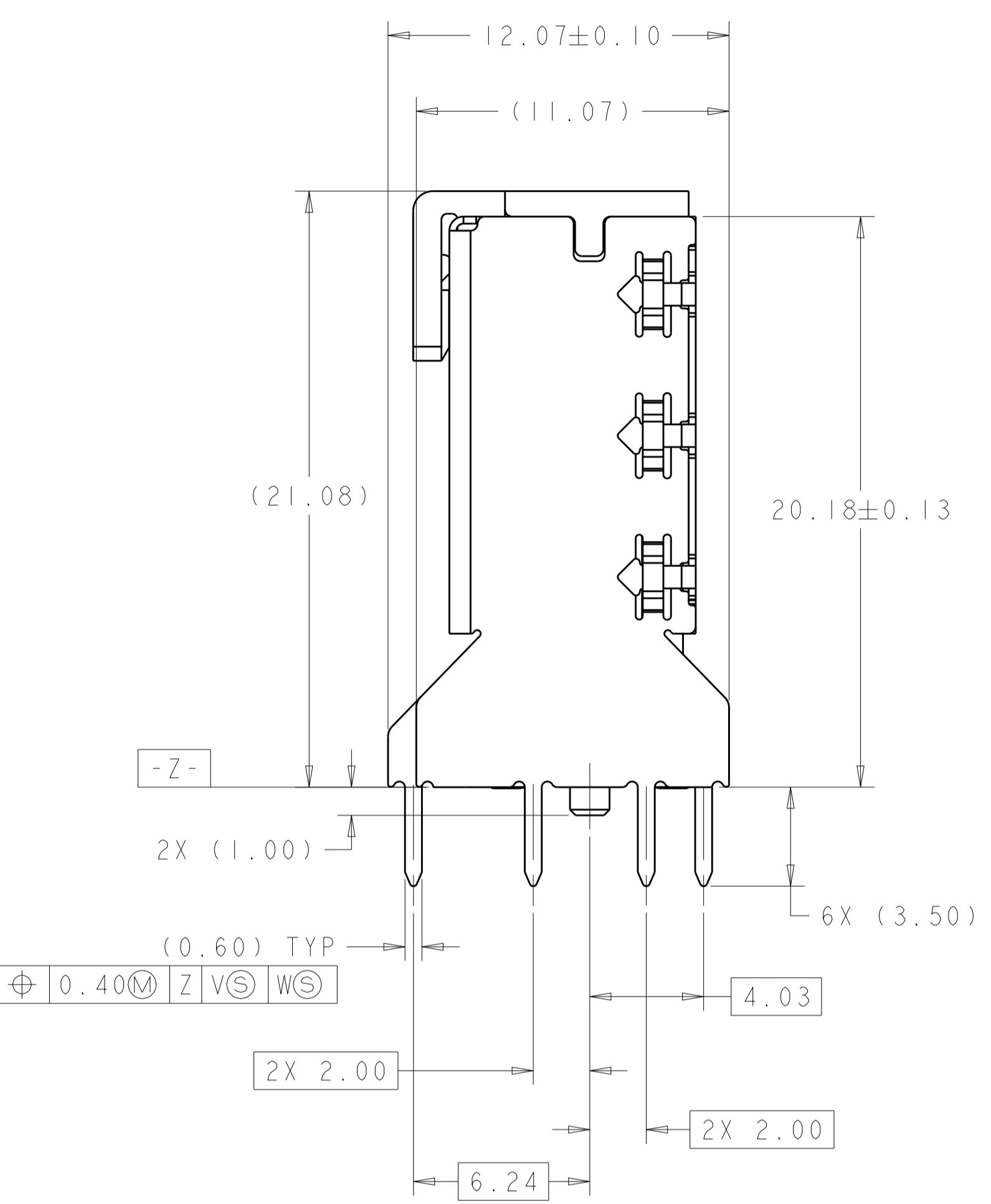

- 1 MATERIAL: LCP, BLACK.
- 2 MATERIAL: PHOSPHOR BRONZE PER ASTM B 103.
- 3 FINISH: 0.76µm MIN GOLD PLATE PER ASTM B 488, APPLIES TO INTERFACE AREA AND 2.03µm MIN TIN PLATE SOLDER TAILS, ALL OVER 3.81µm MIN NICKEL PLATE PER QQ-N-290.
- 4 MATERIAL: NICKEL-SILVER PER ASTM B 122.
- 5 DATUM AND BASIC DIMENSION ESTABLISHED BY CUSTOMER.
- 6 CONTACT TAILS TO BE 0.25 MAX BELOW OR FLUSH WITH DATUM 2.
- 7. REFER TO CUSTOMER DRAWING 1888020 FOR CONNECTOR DETAILS.
- 8 FINISH: 0.38µm MIN GOLD PLATE PER ASTM B 488, APPLIES TO INTERFACE AREA AND 2.03µm MIN TIN PLATE SOLDER TAILS, ALL OVER 3.81µm MIN NICKEL PLATE PER QQ-N-290.

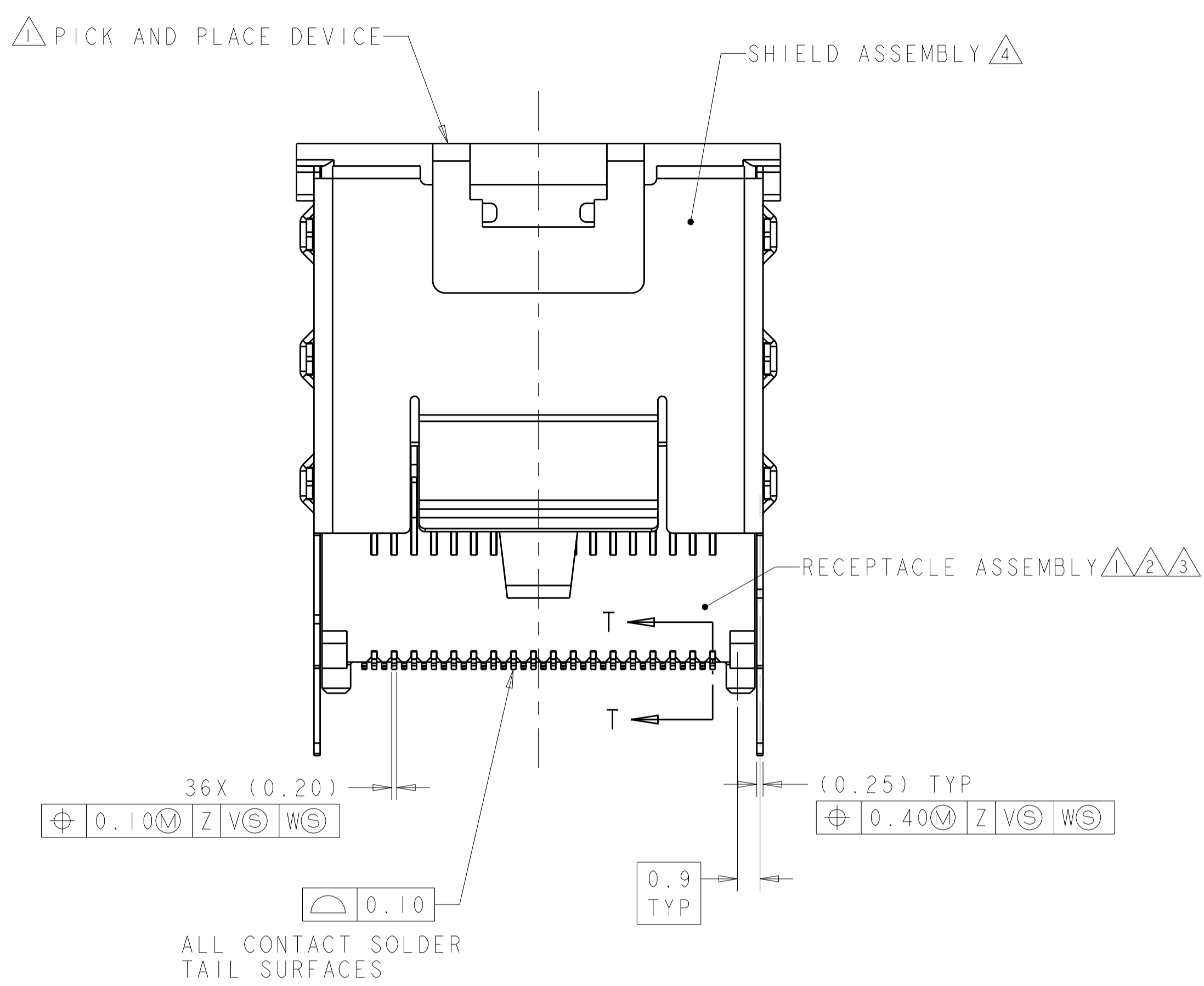
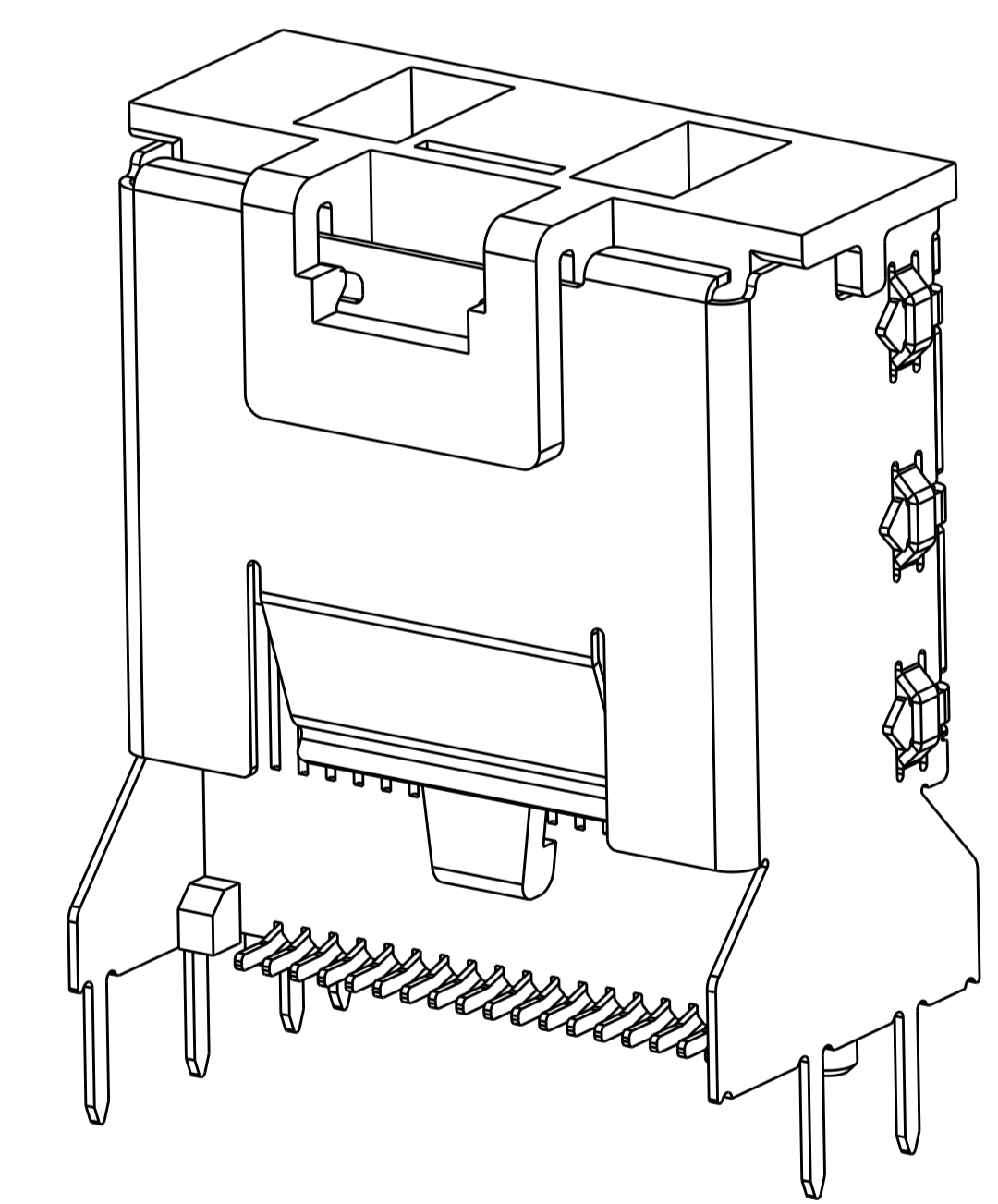
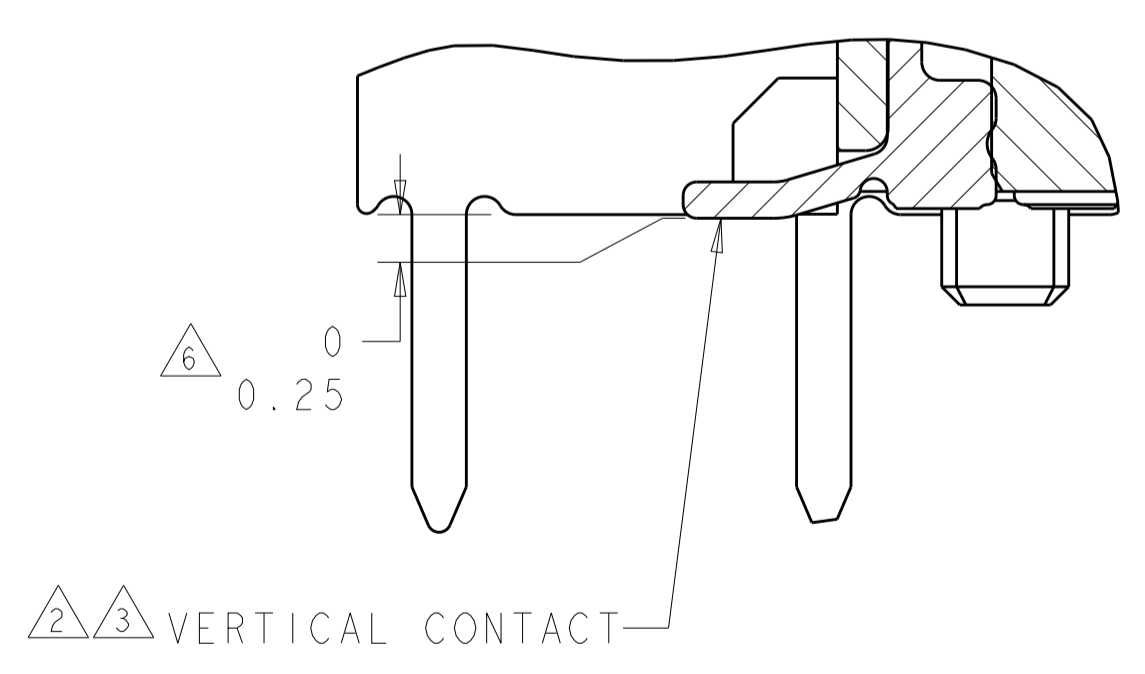
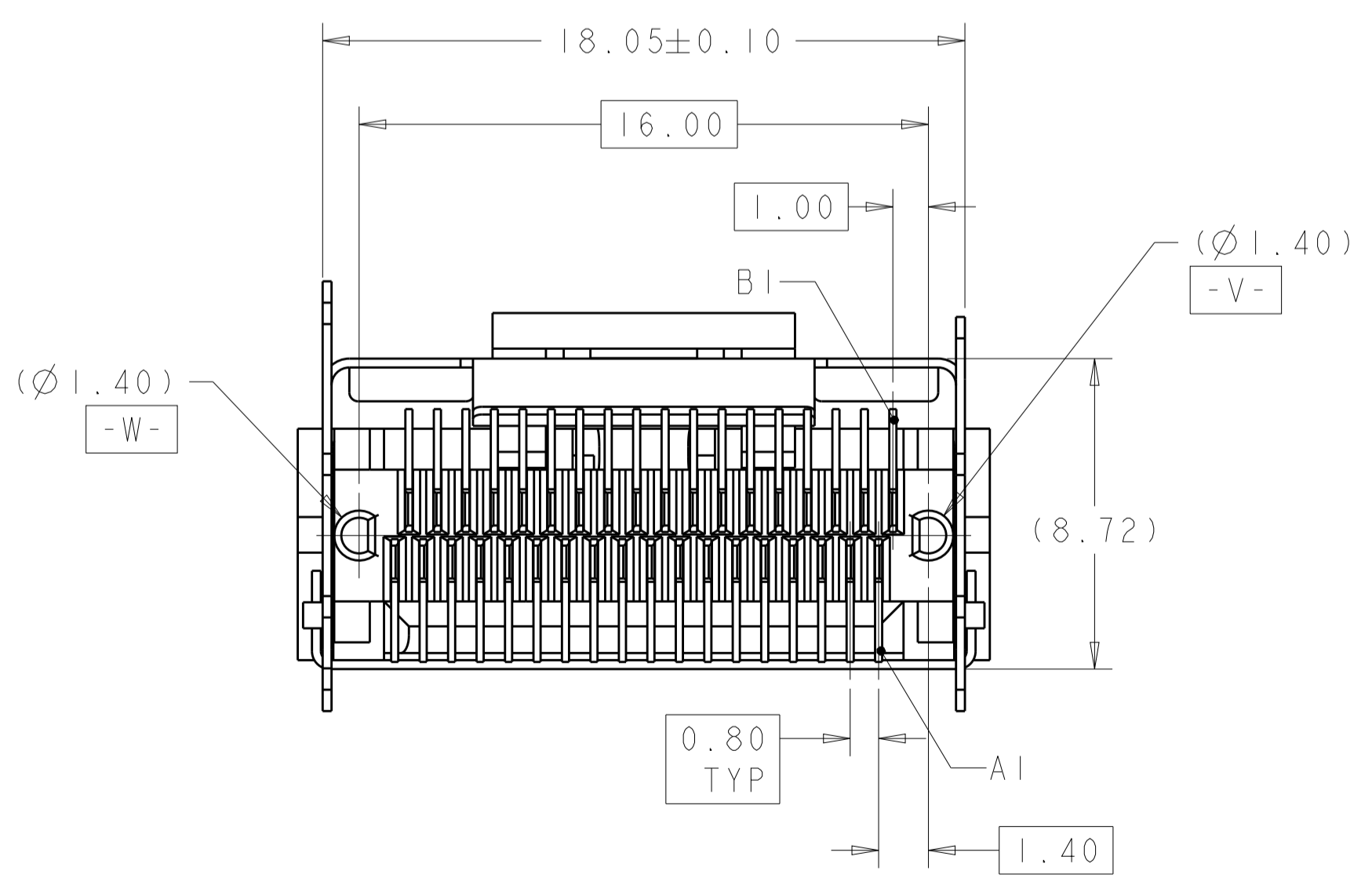

FINISH	POSN	PART NUMBER
8	36	1888957-2
3	36	1888957-1

DIMENSIONS: mm 		TOLERANCES UNLESS OTHERWISE SPECIFIED: 0 PLC ± 1 PLC ±0.10 2 PLC ± 3 PLC ± 4 PLC ± ANGLES ± FINISH ±		DWN B. MCMASTER 23FEB07 CHK D. GORENC 23FEB07 APVD D. GORENC 23FEB07 NAME PRODUCT SPEC 108-2234 APPLICATION SPEC WEIGHT CUSTOMER DRAWING		Tyco Electronics Harrisburg, PA 17105-3608 EVERCLEAR Mini-SAS, VERTICAL, INTERNAL RECEPTACLE ASSEMBLY, WITH SHIELD SIZE CAGE CODE DRAWING NO A 100779 C=1888957 SCALE 6:1 SHEET 1 OF 2 REV A	
-----------------------	--	---	--	---	--	---	--

LOC	DIST	REVISIONS			
P.	LTN	DESCRIPTION	DATE	DMN	APVD
-	-	SEE SHEET 1	-	-	-

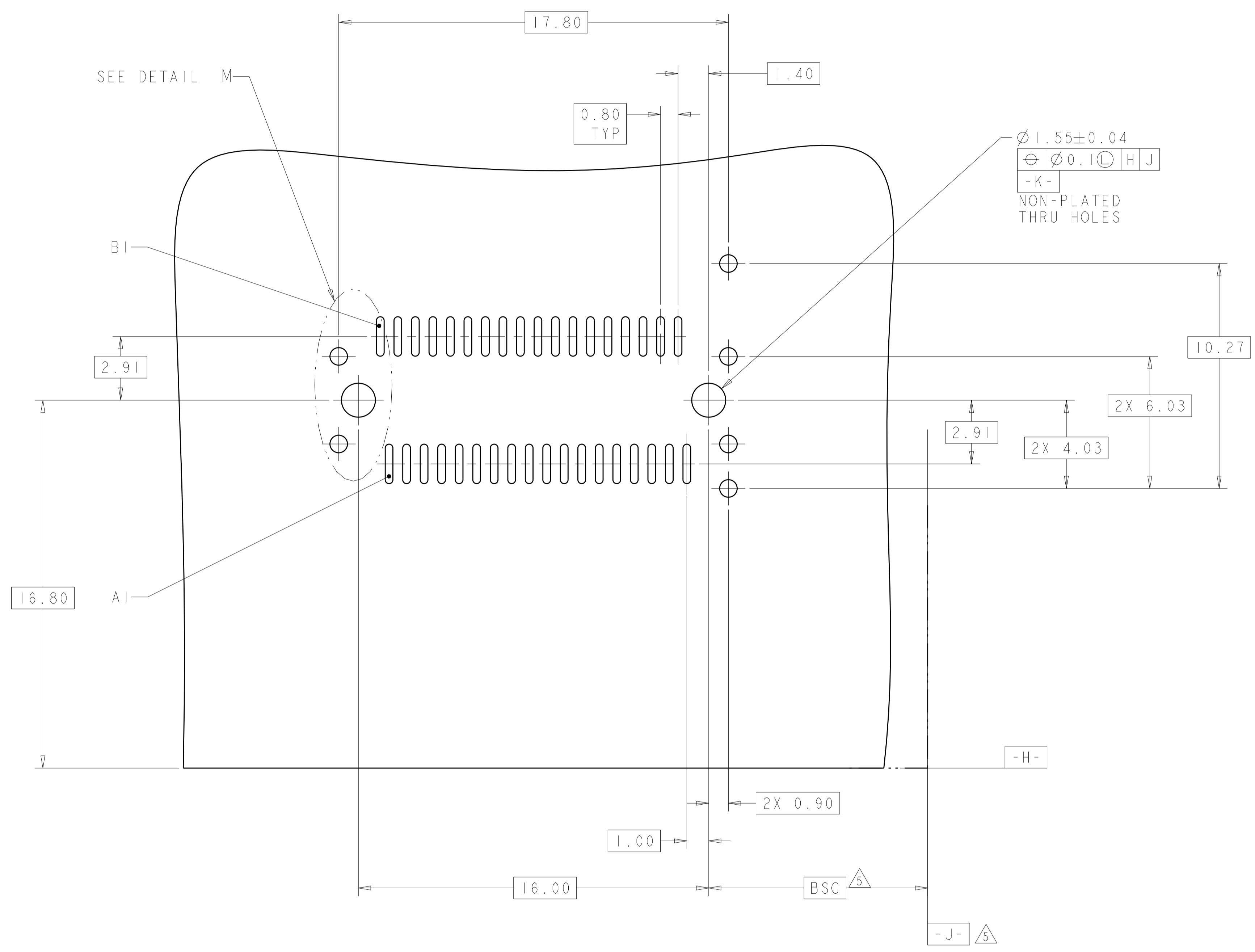

RECOMMENDED PCB LAYOUT
 SCALE 8:1

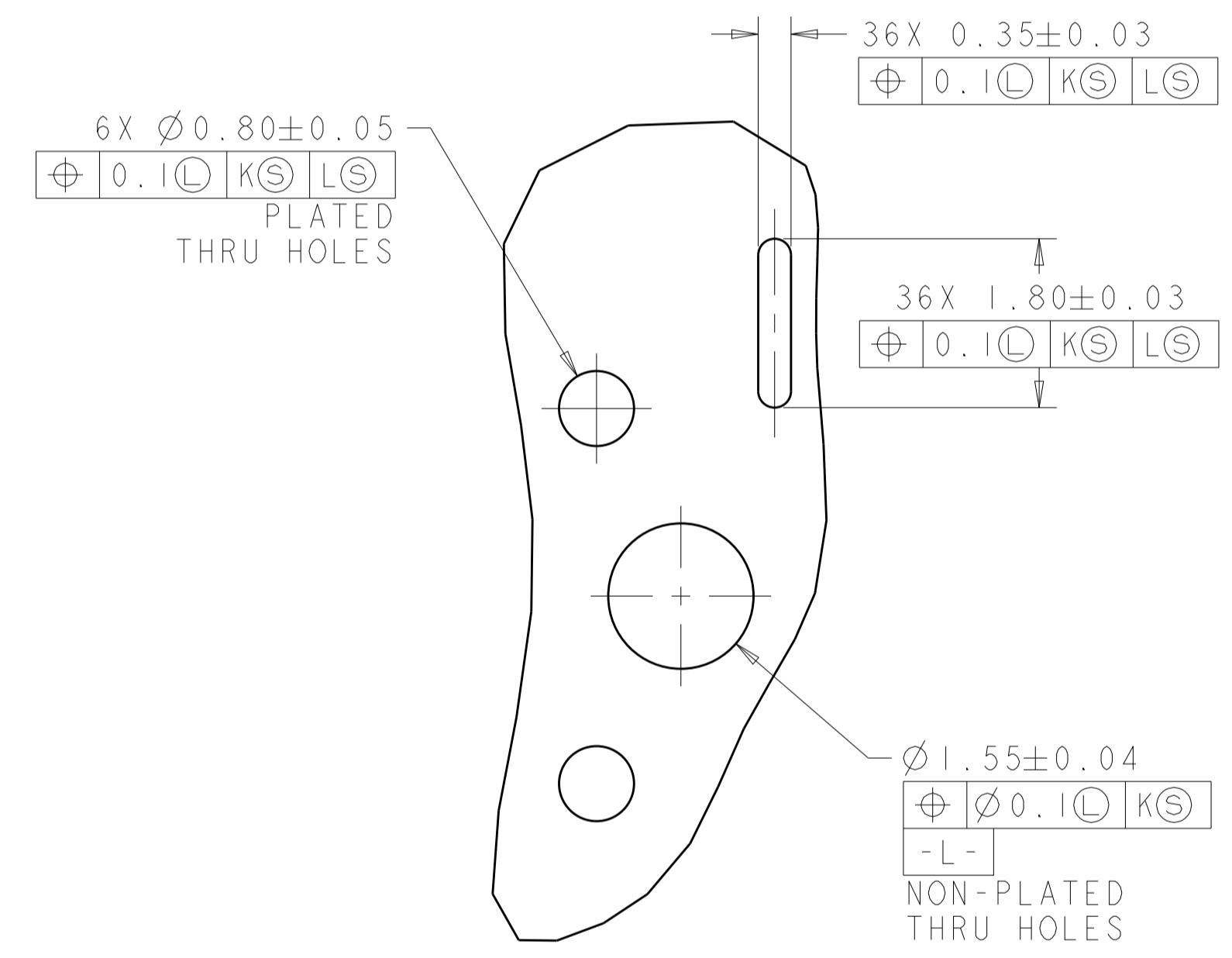

DETAIL M
 SCALE 16:1

<small>THIS DRAWING IS UNPUBLISHED. RELEASED FOR PUBLICATION BY TYCO ELECTRONICS CORPORATION. ALL RIGHTS RESERVED.</small>		DWN B. MCMASTER 23FEB07 CHK D. GORENC 23FEB07 APVD D. GORENC 23FEB07	Tyco Electronics NAME EVERCLEAR Mini-SAS, VERTICAL, INTERNAL RECEPTACLE ASSEMBLY, WITH SHIELD PRODUCT SPEC 108-2234 APPLICATION SPEC
DIMENSIONS: mm 	TOLERANCES UNLESS OTHERWISE SPECIFIED: 0 PLC ± 1 PLC ±0.10 2 PLC ± 3 PLC ± 4 PLC ± ANGLES ±	SIZE A100779 CAGE CODE C=1888957 WEIGHT CUSTOMER DRAWING	RESTRICTED TO SCALE 5:1 SHEET 2 OF 2 REV A

单击下面可查看定价，库存，交付和生命周期等信息

[>>TE Connectivity\(泰科\)](#)