

PREFERRED MOUNTING SITUATION FOR CABLE TIE  
 Bevorzugte Montagestellung fuer Kabelbinder

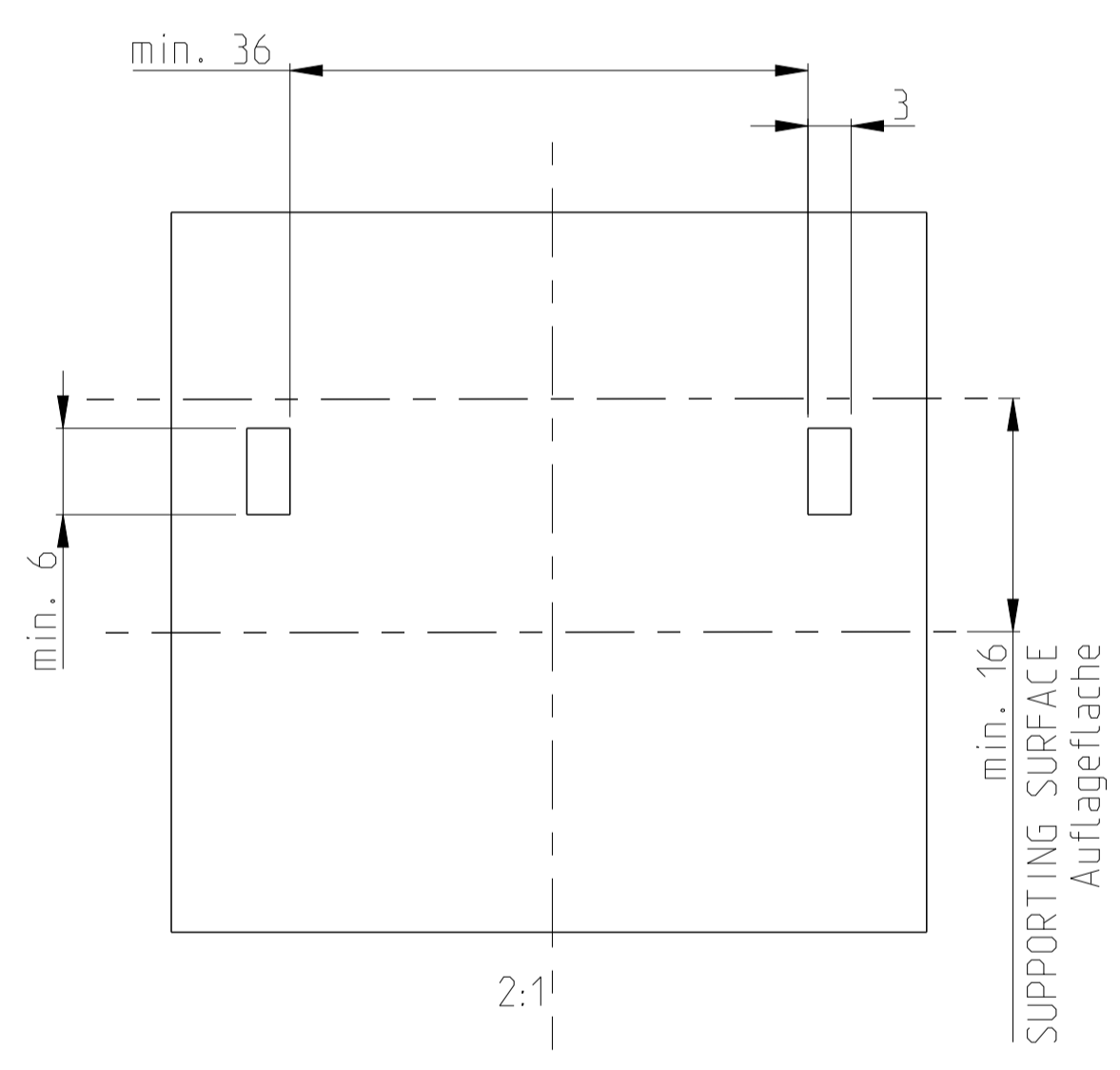

SECTION J-J  
 Schnitt

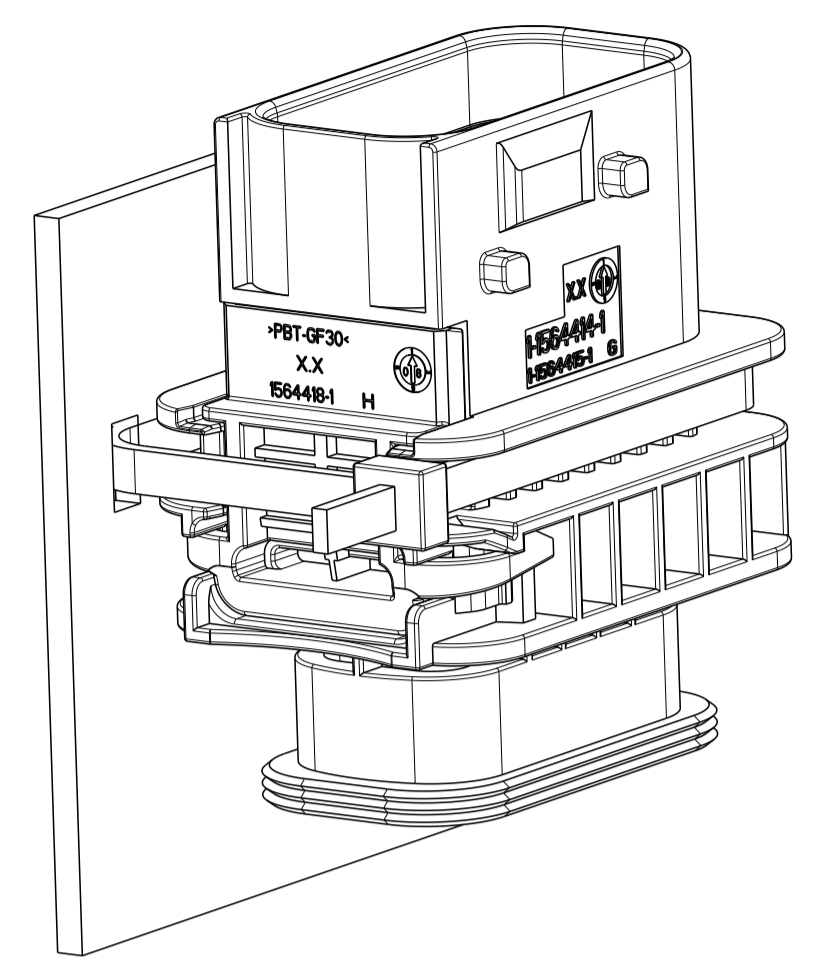
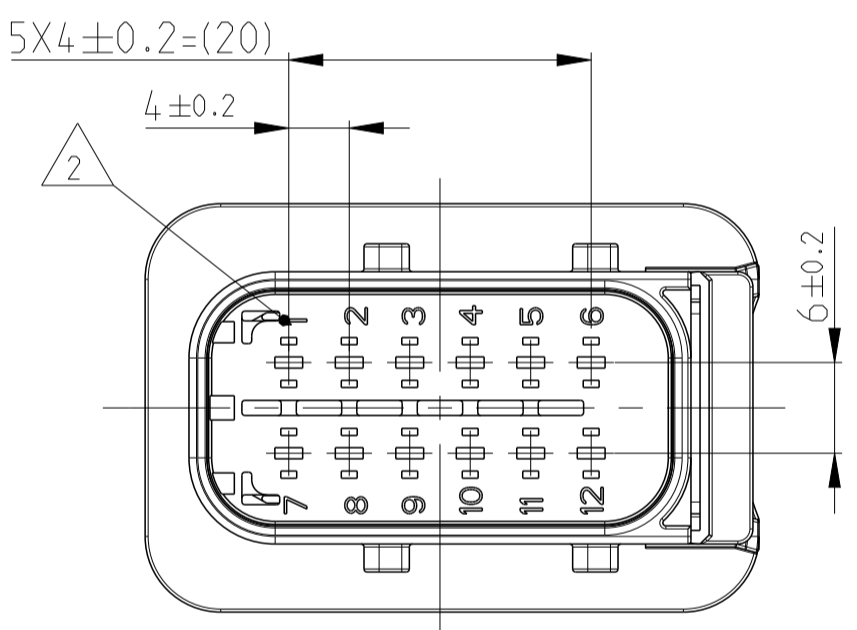
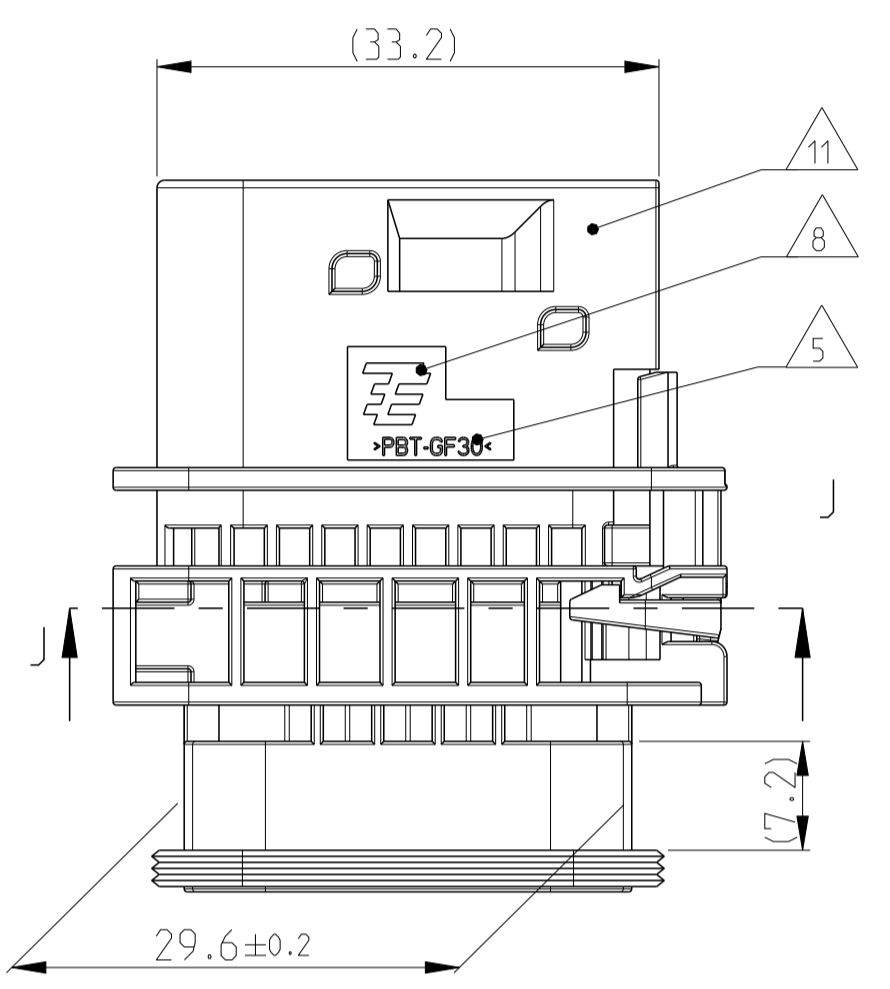
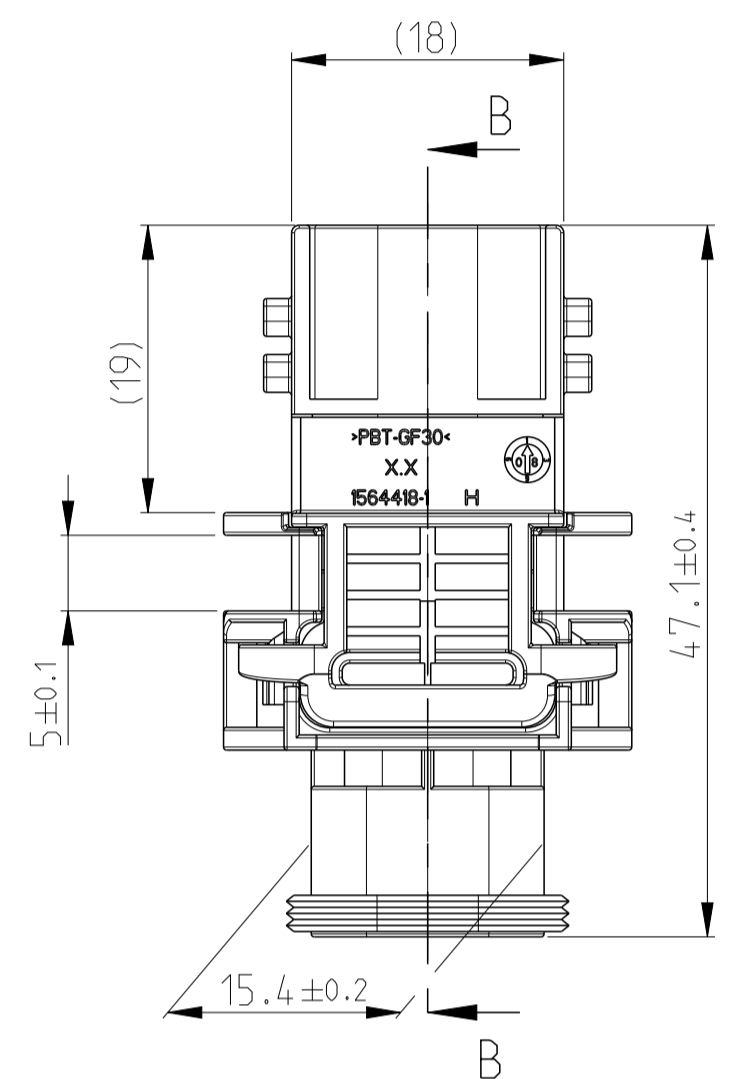
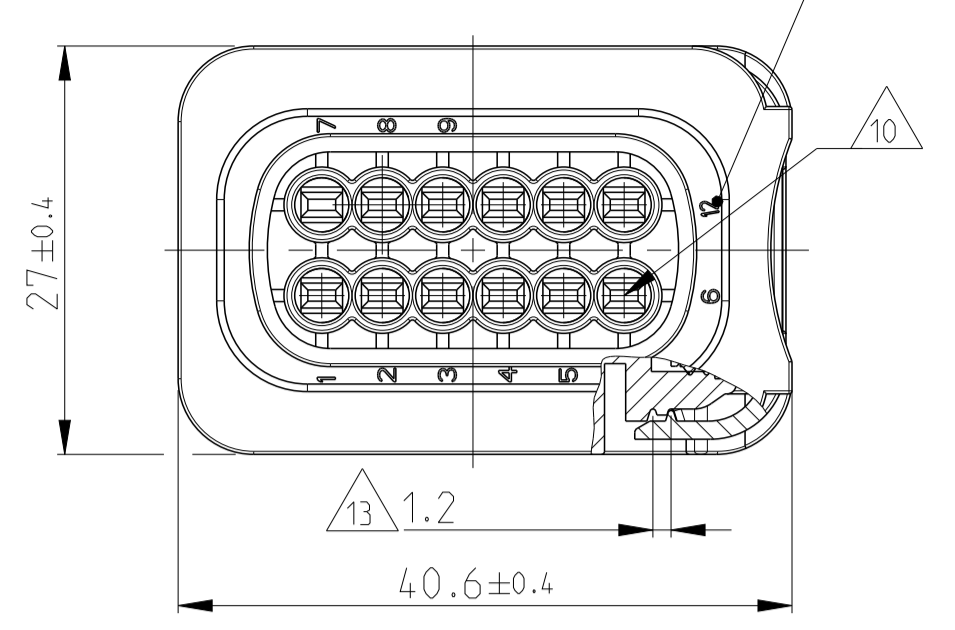

1-1564414-1 AS SHOWN  
 1-1564414-1 wie gezeigt

DELIVERY CONDITION:  
 SECONDARY LOCKING DEVICE  
 IN PRE-LOCKED POSITION  
 Lieferzustand:  
 2. Kontaktsicherung in Vorraststellung

SECTION B-B  
 Schnitt

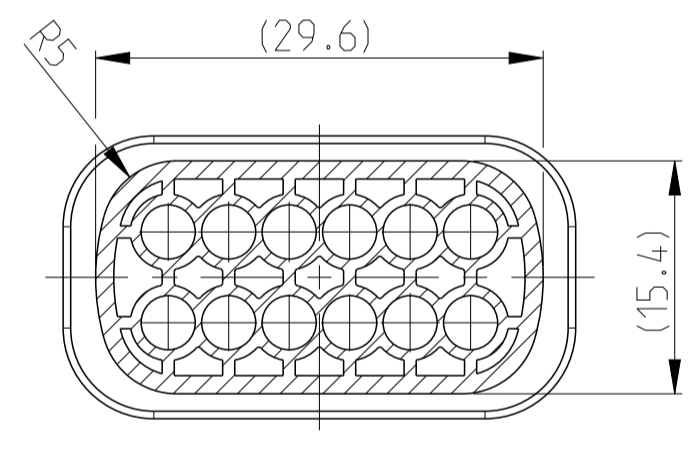
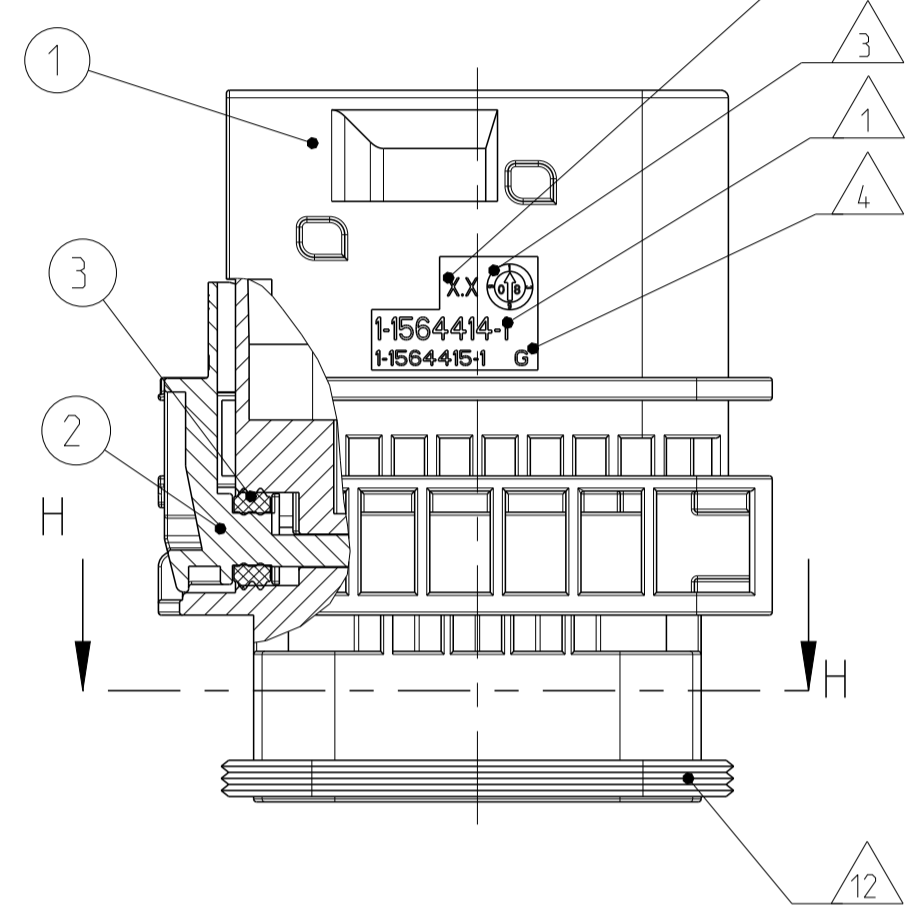

SECTION H-H  
 Schnitt

LOC	DIST	REV	DATE	BY	CHKD	APVD
A1	-	G	19FEB2009	SJ	JG	
		G1	25MAY2011	CG	JG	
		G2	27APR2016	MAH	GILC	
		G3	17APR2018	HO	GILC	

TE LOGO RELATED TO MOLDING TOOL  
 TE LOGO abhaengig vom Spritzgusswerkzeug

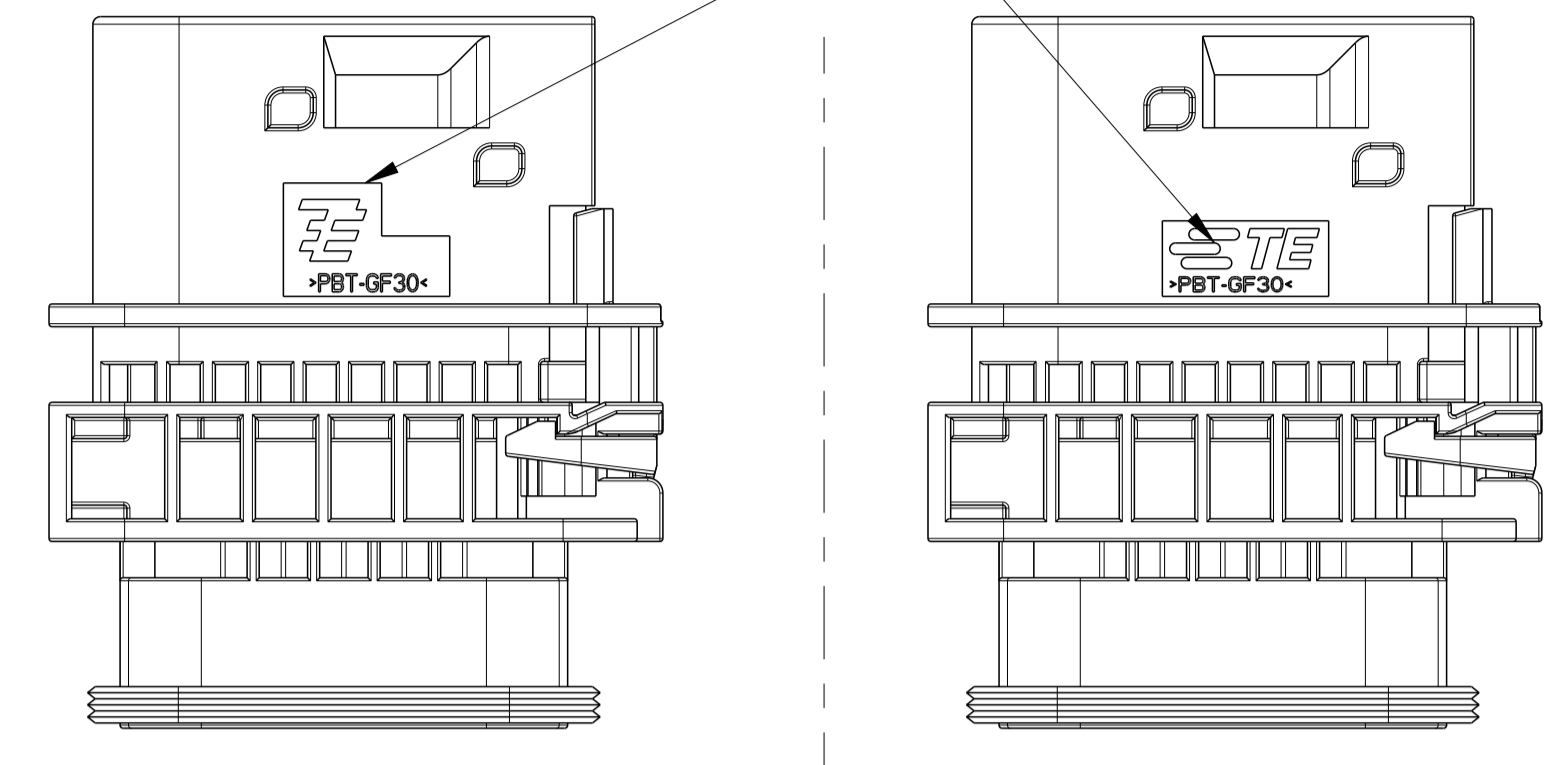

NOTES  
 Bemerkungen

- 1 TE ORDER-NO.  
TE Bestell-Nr.
- 2 CAVITY NUMBERING  
Kammerbezeichnung
- 3 PRODUCTION DATE  
Produktionsdatum
- 4 LETTER-INSERT FOR THE REVISION STATUS OF THE MOULD  
Schriftsatz fuer Aenderungszustand des Werkzeuges
- 5 MATERIAL MARKING ACCORDING TO VDA 260  
Werkstoffkennzeichnung nach VDA 260
- 6 BULK PACKAGING IN CORRUGATED BOX  
Schueltlgut im Versandkarton
- 7 MOULD CAVITY MARKING  
Nestmarkierung
- 8 TE LOGO  
TE Logo
- 9 SUITABLE COUNTERPART SEE DRAWING: 1703639  
passendes Gegenstueck siehe Zeichnung: 1703639
- 10 CAVITIES MATED WITH TAB 1.6 x 0.6 MM (SW'S)  
SEE PRODUCT GROUP DRAWING  
TE NO: 1355055  
MAX. WIRE SIZE: 1.0mm<sup>2</sup> FLR  
  
WIRE SIZE: 1.5mm<sup>2</sup> FLR PERMITTED ONLY IN  
ASSOCIATION WITH  
SINGLE WIRE SEALING PN 0-2287497-1  
ALLOWED TEMPERATURE 120 DEGREE CELSIUS  
  
Kontaktkammer passend fuer Flachstecker 1.6x0.6 mm (EDS)  
siehe Produktgruppenzeichnung  
TE Nr: 1355055  
max. Drahtgrossenbereich: 1.0mm<sup>2</sup> FLR  
  
Es ist ein Drahtgrossenbereich von 1.5mm<sup>2</sup> FLR nur  
in Verbindung  
mit der Einzelleiterdichtung PN 0-2287497-1  
bis zu 120°C zugelassen
- 11 INTERFACE ACC. Drawing: 114-18807-1  
KragenschluB nach Zeichnung: 114-18807-1
- 12 MATED WITH COVER SEE DRAWING: 1563110, 1563111  
Passend zu Kappe siehe Zeichnung: 1563110, 1563111
- 13 SLIDING DISTANCE OF SECONDARY LOCKING  
Verschiebeweg der zweiten Kontaktsicherung
- 14 MALFUNCTION CAUSED BY LAQUER IS NOT  
COVERED BY TE WARRANTY  
Funktionsbeeintrachtigung durch Lackieren, liegt nicht  
im Einfluss und Gewaehrleistungsumfang von TE

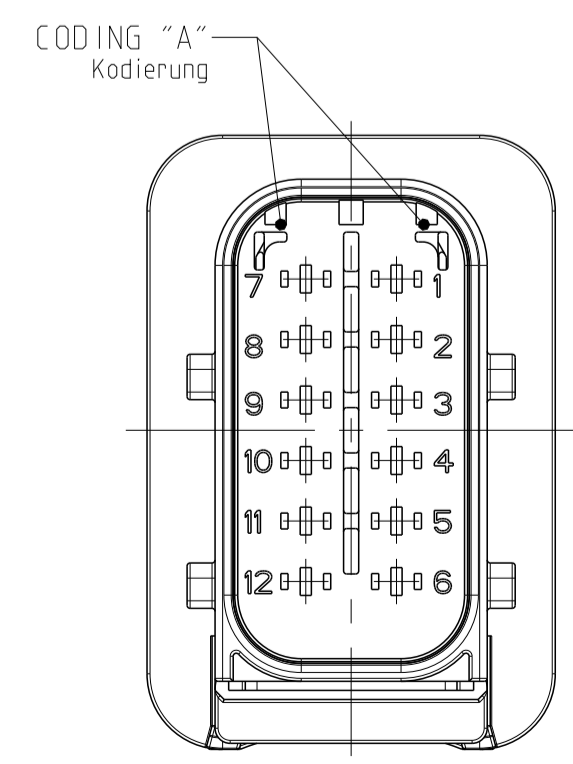

CODING "A"  
 Kodierung  
 PN: 1-1564414-1

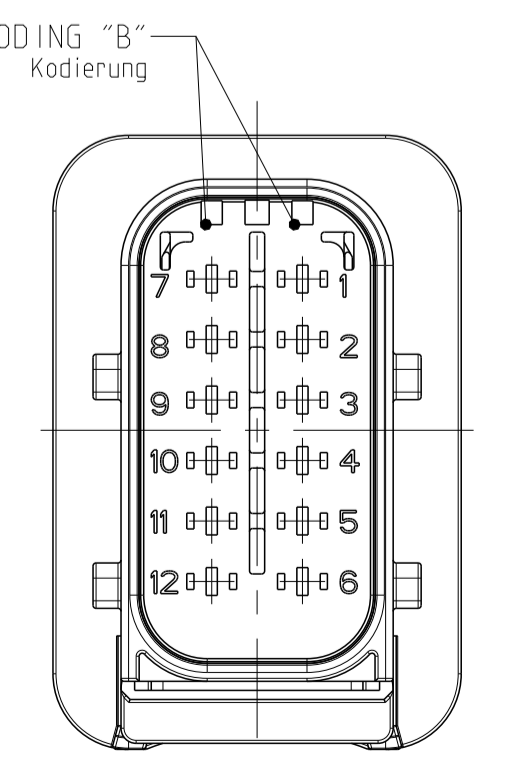

CODING "B"  
 Kodierung  
 PN: 2-1564414-1

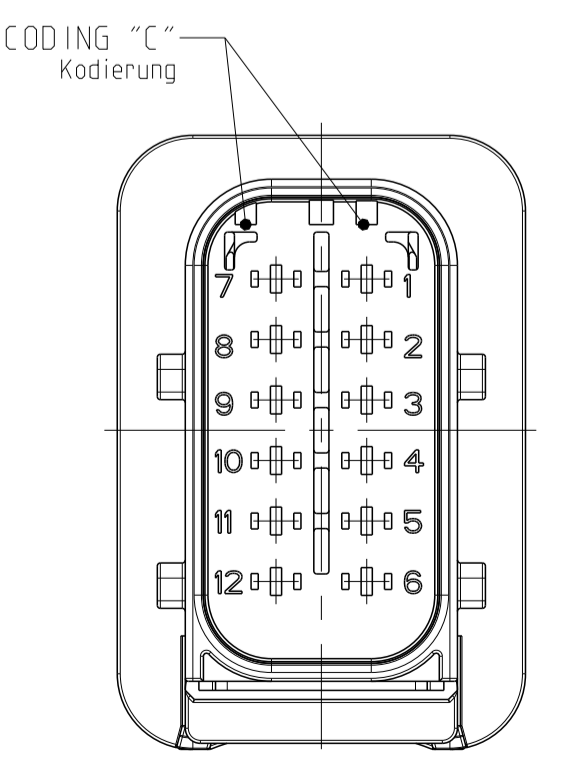

CODING "C"  
 Kodierung  
 PN: 3-1564414-1

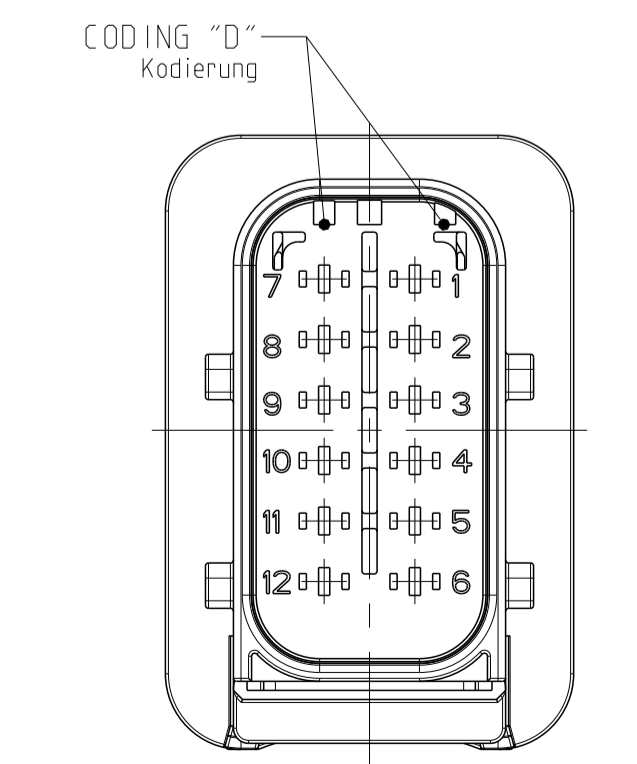

CODING "D"  
 Kodierung  
 PN: 4-1564414-1

ITEM NO	DESCRIPTION	COLOUR	MATERIAL
1	12POS. TAB HOUSING, CODE "A" 12pos. Flachsteckergehäuse, Kod. "A"	BLACK schwarz	PBT-GF30 / V-0
1	12POS. TAB HOUSING, CODE "B" 12pos. Flachsteckergehäuse, Kod. "B"	GREY grau	PBT-GF30 / V-0
1	12POS. TAB HOUSING, CODE "C" 12pos. Flachsteckergehäuse, Kod. "C"	GREEN gruen	PBT-GF30 / V-0
1	12POS. TAB HOUSING, CODE "D" 12pos. Flachsteckergehäuse, Kod. "D"	BLUE blau	PBT-GF30 / V-0
2	SECONDARY LOCKING DEVICE zweite Kontaktsicherung	YELLOW gelb	PBT-GF30 / V-0
3	SEAL FOR SECONDARY LOCKING Dichtung fuer 2te Kontaktsicherung	WHITE weiss	MVO

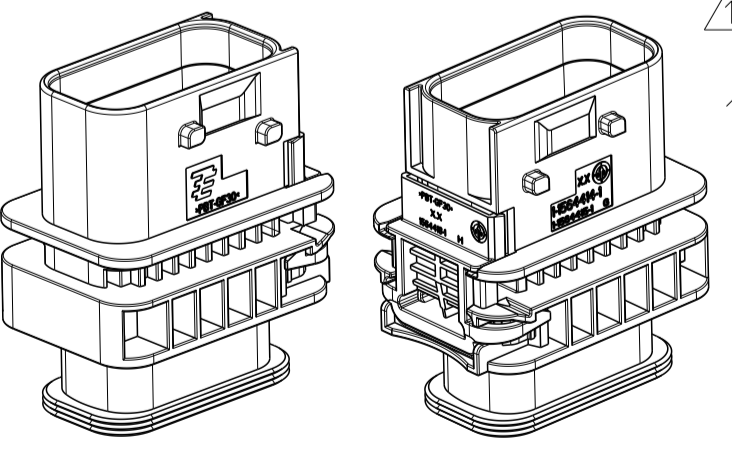

SCALE 1:1  
 Massstab

SCALE 1:1  
 Massstab

REV.	TE ORDER-NO.	REV.	NO. OF POS.	CODE	QUANTITY	ITEM	DESCRIPTION
TE Bestell-Nr.	REV.	Polzahl	Kodierung	Stueck	NO	ASSY	DESCRIPTION
	4-1564414-1	G	12	D	1	4	THIS DRAWING IS A CONTROLLED DOCUMENT. DIESER ZEICHNUNGSDRUCK IST NUR DURCH AMF REPRODUZIERTE VERTRETLICH. ANSONSTEN IST DIESER DRUCK NICHT VERWENDBAR. THIS DRAWING IS UNAPPROVED FOR PUBLICATION. VERBODEN VOOR PUBLISATIE.
	3-1564414-1	G	12	C	1	3	OWN: A.Kidane 09MAY2008 CHK: F.Filtron 09MAY2008 APVD: E.Huberweim 12MAY2008
	2-1564414-1	G	12	B	1	1	NAME: 12 POS. TAB 1.6x0.6.TAB HSG. ASSY 12 pos. TAB 1.6x0.6 Flachsteckergehäuse HDS - GROUP D
	1-1564414-1	G	12	A	1	1	PRODUCT SPEC: 108-94020 APPLICATION SPEC: VERARBEITUNGSPEZ. 114-18756
							SIZE: A1 CAGE CODE: 00779 DRAWING NO: 1564414 WEIGHT: 18.65g
							CUSTOMER DRAWING /KUNDENZEICHNUNG SCALE: MASSSTAB 2:1 SHEET: 1 OF 1 REV: G3

单击下面可查看定价，库存，交付和生命周期等信息

[>>TE Connectivity\(泰科\)](#)