

THIS DRAWING IS UNPUBLISHED. RELEASED FOR PUBLICATION
 © COPYRIGHT - By - ALL RIGHTS RESERVED.

LOC	DIST	REVISIONS			
P	LTR	DESCRIPTION	DATE	DWN	APVD
G	86	A1	REVISED PER ECO-11-024755	13DEC11	KH DR

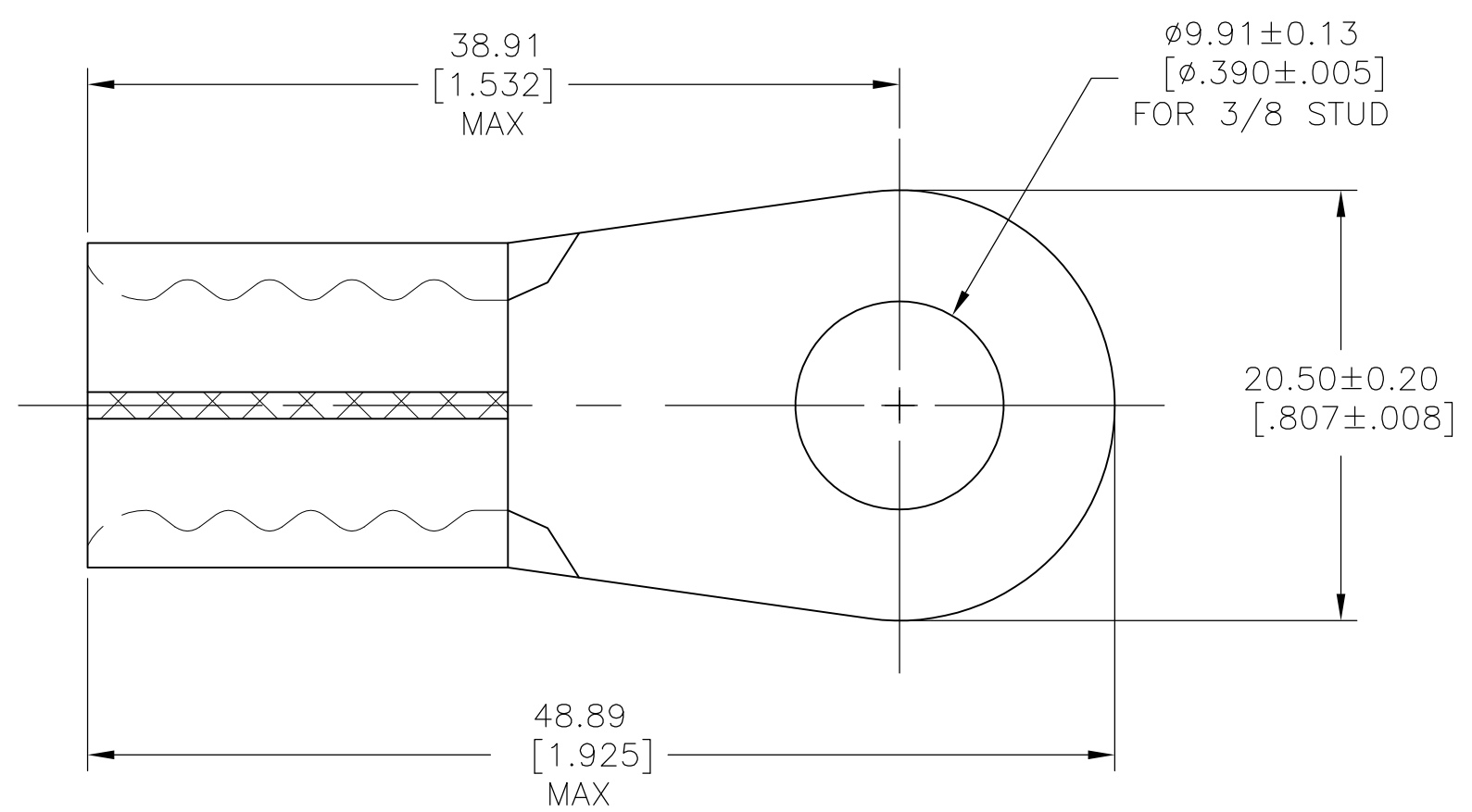

- 1 WIRE RANGE IS FOR 1/0 AWG STANDARD. WIRE CROSS SECTIONAL AREA RANGE: 83,700-119,500 CMA, STRANDED WIRE
- 2 THE TONGUE THK IS 1.77 ± 0.076 [.070 ± .003]
- 3 RECOMMENDED OPERATING TEMP -55°C TO +200°C FOR HEAT SHRINK TUBING

1	1-1196717-9	HIGH AND LOW TEMPERATURE CROSS LINKED FLOUROPOLYMER HEAT SHRINK TUBING 15.875[.625]MIN IDX44.45 ± 3.05[1.75 ± .12] RT555-5/8-0-SP
1	321868-1	TERMINAL BODY: COPPER PER ASTM B-152 ANNEALED FINISH: NICKEL PLATE .000300 MIN THK PER SAE AMS QQ-N-290
-1	PART NO	DESCRIPTION

THIS DRAWING IS A CONTROLLED DOCUMENT.		DWN JR RUTH 08DEC09	STE TE Connectivity														
DIMENSIONS: mm [INCHES]		CHK T MICHELUTTI 08DEC09															
TOLERANCES UNLESS OTHERWISE SPECIFIED:		APVD T MICHELUTTI 08DEC09	NAME HEAT RESISTANT TERMINAL KIT														
<table border="0"> <tr><td>0 PLC</td><td>± -</td></tr> <tr><td>1 PLC</td><td>± -</td></tr> <tr><td>2 PLC</td><td>± -</td></tr> <tr><td>3 PLC</td><td>± -</td></tr> <tr><td>4 PLC</td><td>± -</td></tr> <tr><td>ANGLES</td><td>± 1°</td></tr> </table>		0 PLC	± -	1 PLC	± -	2 PLC	± -	3 PLC	± -	4 PLC	± -	ANGLES	± 1°	PRODUCT SPEC -	RESTRICTED TO -		
0 PLC	± -																
1 PLC	± -																
2 PLC	± -																
3 PLC	± -																
4 PLC	± -																
ANGLES	± 1°																
MATERIAL -		FINISH -	APPLICATION SPEC -	SIZE A3	CAGE CODE 00779	DRAWING NO C-696647											
CUSTOMER DRAWING			WEIGHT -	SCALE 3:1	SHEET 1 OF 1	REV A1											

单击下面可查看定价，库存，交付和生命周期等信息

[>>TE Connectivity\(泰科\)](#)