

THIS DRAWING IS UNPUBLISHED. RELEASED FOR PUBLICATION 20
 © COPYRIGHT 20 BY - ALL RIGHTS RESERVED.

LOC	DIST	REVISIONS					
B	E	P	LTR	DESCRIPTION	DATE	DWN	APVD
		N		ECO-21-006957	25JUN2021	RK	MZ

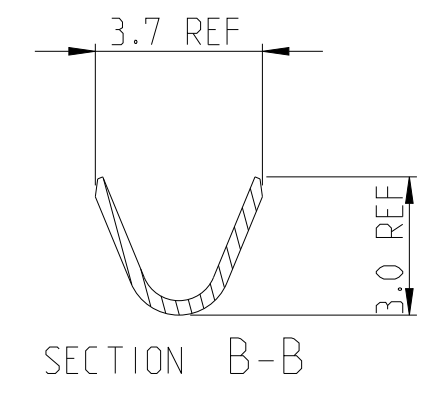
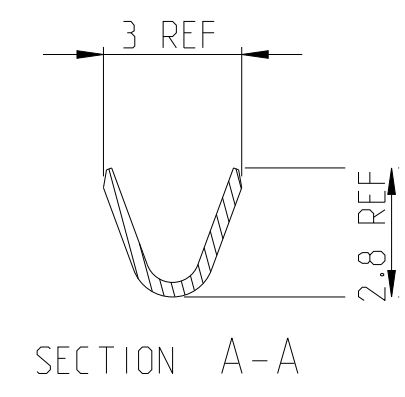
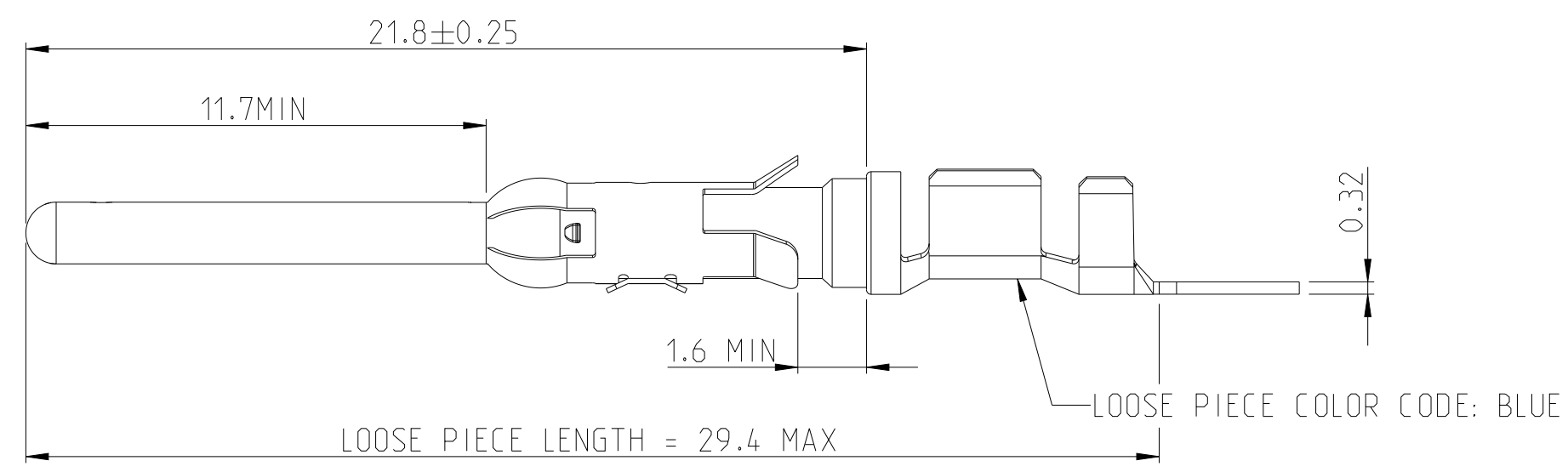
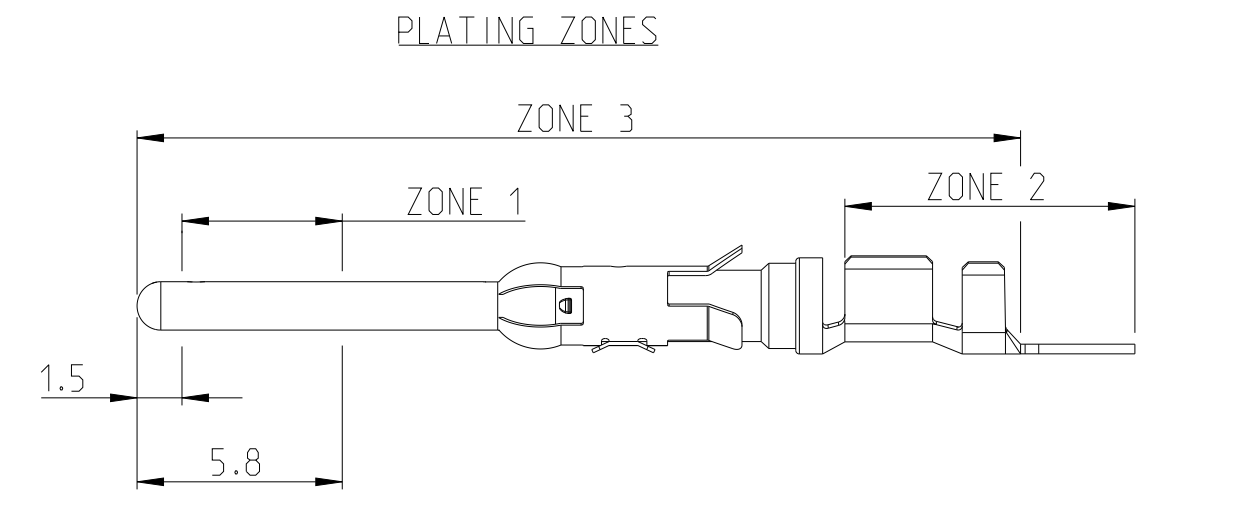
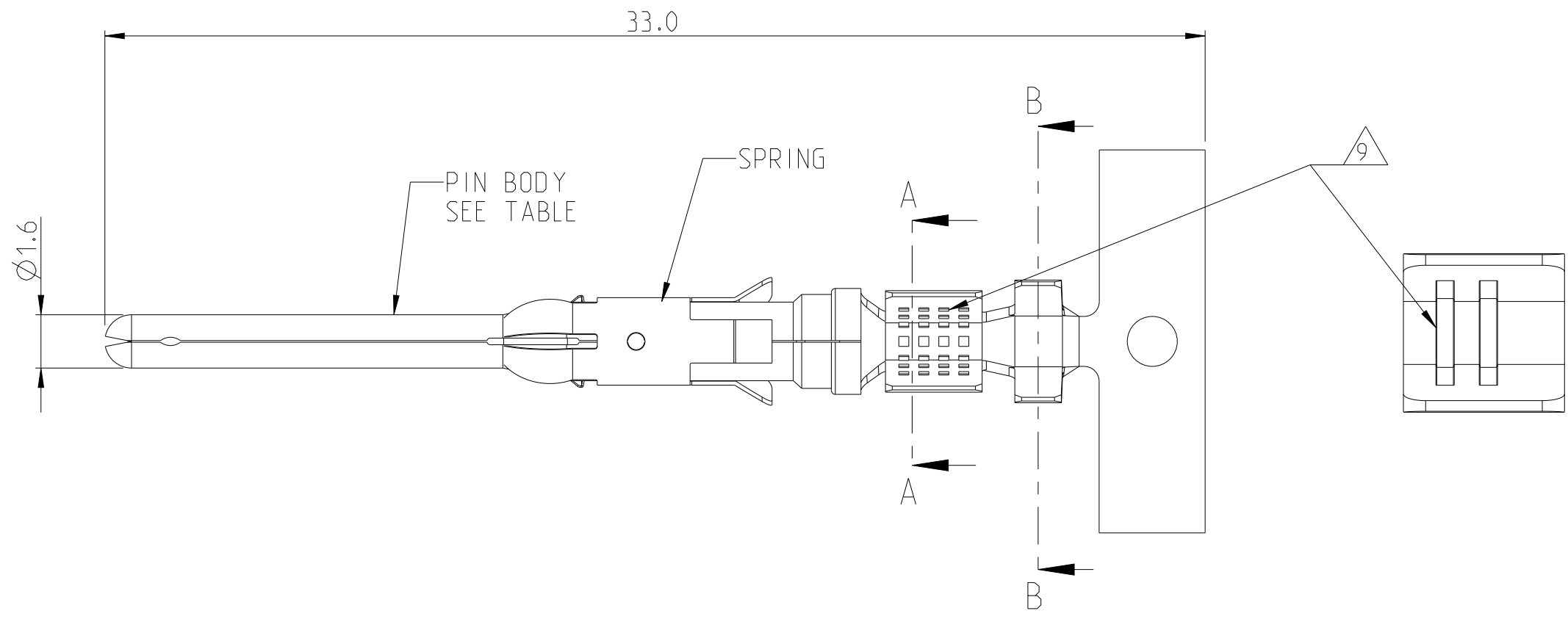

NOTES

- 1 1.27 MICRON MIN NICKEL PLATE OVER ZONE 3.
0.76 MICRON MIN PRECIOUS METAL PLATE OVER ZONE 1.
1 MICRON MIN TIN PLATE OVER ZONE 2.
CONFORMS TO THE REQUIREMENTS OF TE CONNECTIVITY PRODUCT SPEC 108-10042
BASED ON EIA/ECA-364-1000.01A (CONTROLLED ENVIRONMENT APPLICATIONS)
- 2 1.27 MICRONS MIN NICKEL PLATE OVER ZONE 3.
0.76 MICRON MIN PRECIOUS METAL ELECTROPLATE OVER ZONE 1.
0.076 MICRON MIN GOLD FLASH PLATE OVER THE REMAINDER OF ZONE 3.
CONFORMS TO THE REQUIREMENTS OF TE CONNECTIVITY PRODUCT SPEC 108-10042
BASED ON EIA/ECA-364-1000.01A (CONTROLLED ENVIRONMENT APPLICATIONS)
- 3 1.54 - 2.54 MICRON SILVER PLATE OVER ZONE 3.
- 4 1.27 MICRON MIN NICKEL PLATE OVER ZONE 3.
0.76 MICRON MIN GOLD PLATE OVER ZONE 1.
0.076 MICRON MIN GOLDFLASH PLATE OVER THE REMAINDER OF ZONE 3.
- 5 1.27 MICRON MIN NICKEL PLATE OVER ZONE 3.
0.76 MICRON MIN GOLD PLATE OVER ZONE 1.
1 MICRON MIN TIN PLATE OVER ZONE 2.
- 6 HOT-DIPPED PRETIN
- 7 1.27 MICRONS MIN NICKEL PLATE OVER ZONE 3.
1 - 3 MICRON ELECTRO-TIN PLATE OVER ZONE 3
- 8 0.76 MICRON MIN NICKEL PLATE OVER ZONE 3 PER QQ-N-290
1.5 - 2.54 MICRON SILVER PLATE OVER ZONE 3.
- 9 SERRATIONS CAN BE MULTI LOCK OR TWO SLOTS.
- 10. WIRE RANGE: 0.75 - 1.50 mm² (18-16 AWG)
- 11. INSULATION RANGE: 2.0 - 2.5 mm (.080-.100) DIA
- 12. OMISSION OF 6 CONTACTS MAX PER REEL OF 5000PCS

A	2	STAINLESS STEEL	PHBR	164164-8	1-164161-5
A	3	STAINLESS STEEL	PHBR	164164-7	1-164161-3
B	3	STAINLESS STEEL	PHBR		1-164161-2
A	6	STAINLESS STEEL	BRASS	164164-6	1-164161-1
A	6	STAINLESS STEEL	BRASS	164164-5	164161-9
A	1	STAINLESS STEEL	BRASS	164164-4	164161-7
B	1	STAINLESS STEEL	BRASS		164161-6
A	1	STAINLESS STEEL	BRASS	164164-2	164161-4
A	7	STAINLESS STEEL	BRASS	164164-1	164161-3
B	2	STAINLESS STEEL	BRASS		164161-2

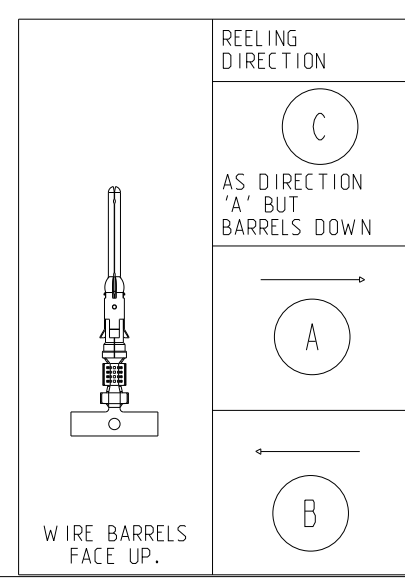

THIS DRAWING IS A CONTROLLED DOCUMENT.	
DIMENSIONS: mm	TOLERANCES UNLESS OTHERWISE SPECIFIED:
0 PLC ±0.5	1 PLC ±0.25
2 PLC ±0.15	3 PLC ±0.15
4 PLC ±	ANGLES ±2°
MATERIAL SEE TABLE	FINISH SEE TABLE

DWN J. BRIGHT 01JUN2012	 TE Connectivity	NAME TYPE III+, SIZE 16, PIN ASS'Y LONG SERIES, 18-16 AWG, 2.0-2.5mm DIA INSULATION		
CHK J. AMBROSE 01JUN2012				
APVD M. GREENER 01JUN2012				
PRODUCT SPEC 108-10042	SIZE A2	CAGE CODE 00779	DRAWING NO. 164161	RESTRICTED TO
APPLICATION SPEC 114-19000	WEIGHT -	SCALE NTS	SHEET 1 OF 1	REV N
CUSTOMER DRAWING				

单击下面可查看定价，库存，交付和生命周期等信息

[>>TE Connectivity\(泰科\)](#)