

REVISIONS			RELEASED	
REV	ECN No.	DESCRIPTION	DATE	APPROVED
U	0154-02	QTY OF ITEM 12 WAS 8	02/10/11	CC
V	0439-02	CORRECTED ORIENTATION OF TERM. DESIG.	02/12/02	CC
W	0198-04	ADDED ITEM 16	04/03/18	CB
Y	0070-05	CHANGE SCREW FROM FLAT TO PHILLIPS	05/02/14	CB
AA	11-024834	ITEM 7 WAS -054	11/12/01	CB

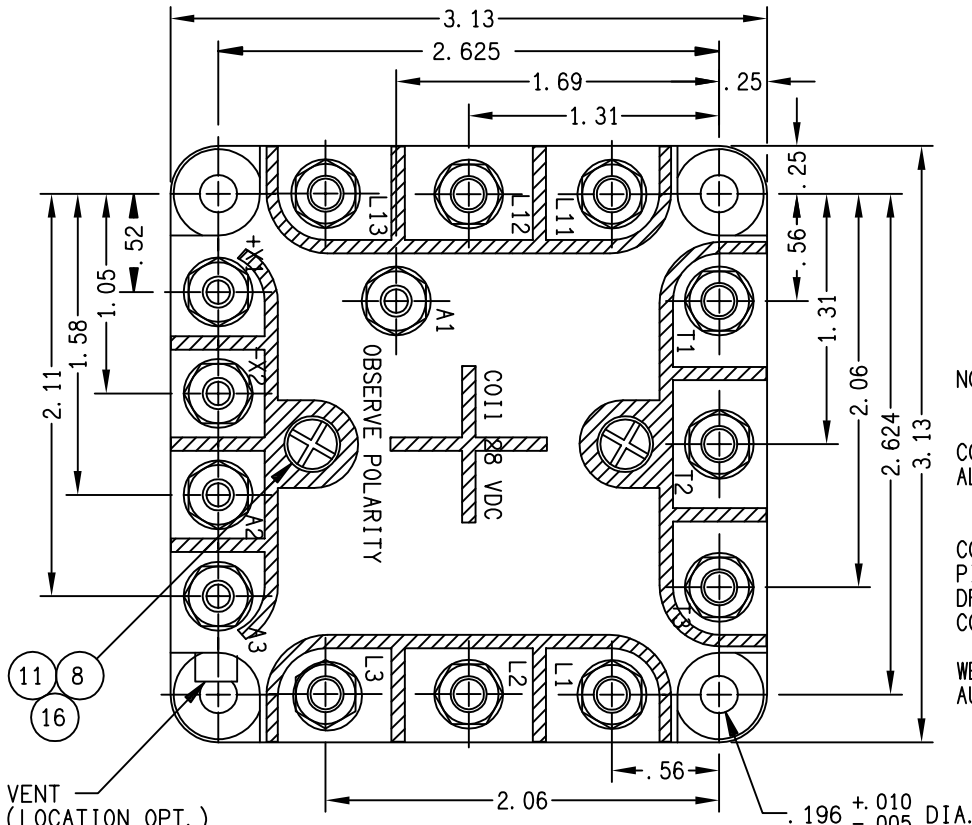

- NOTES:
 1. TERMINAL COVER STAMPED "DANGER HIGH VOLTAGE"
 2. MAX AMBIENT TEMP TO BE 120° C

NOMINAL VOLTAGE
 COIL 28 V DC
 CONTACTS 200 V AC, 400 HZ
 CONTACT RATING 60 AMPS/PHASE
 ALTERNATE RES LOAD RATING
 70A/PHASE AT MAX AMB TEMP 71° C
 75A/PHASE AT MAX AMB TEMP 10° C

CONTACTS TPDT NC
 PICKUP VOLTAGE 18 V MAX (HOT)
 DROPOUT VOLTAGE 7 +0/-5.5 VOLTS
 COIL CURRENT AT 29V (EST) MAX & 25° C .5 AMP
 WEIGHT (MAX) 1 LB 8 1/2 OZ
 AUX CONTACT RATING
 INDUCTIVE 3 AMP
 RESISTIVE 5 AMP
 MOTOR 3 AMP

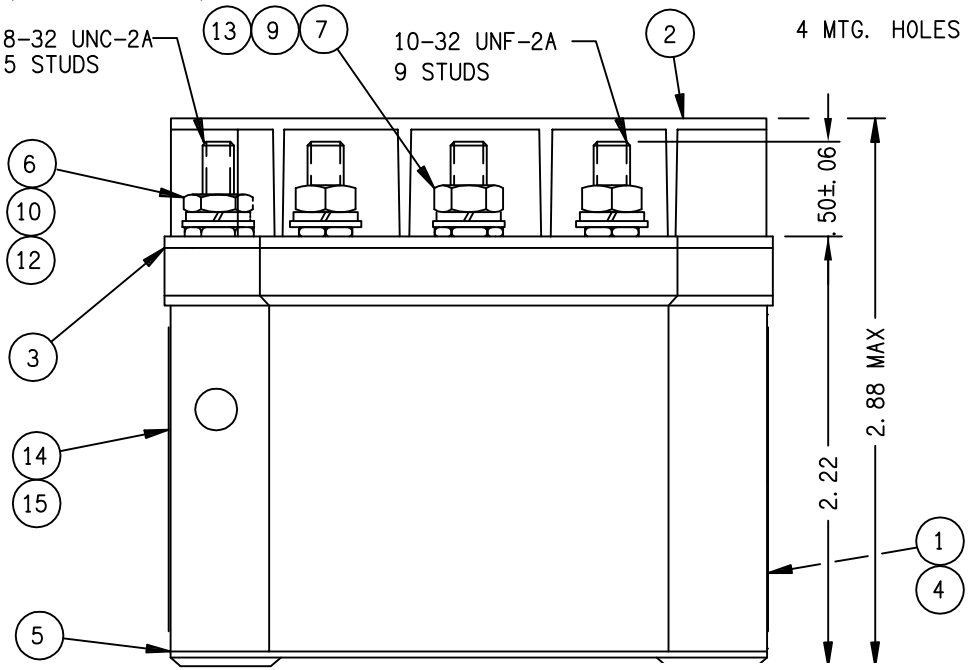
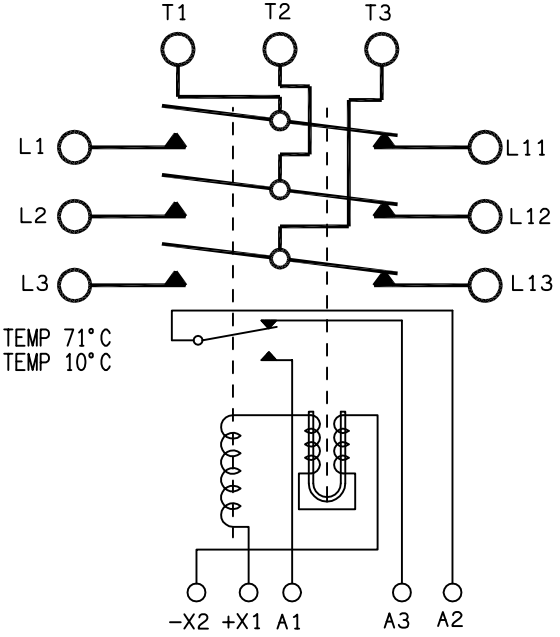

16	2	51701-310	WASHER			
15	1	39529-038	OVERLAY			
14	1	25265-001	PLATE-WIRING DIAGRAM			
13	9	51810-054	WASHER - LOCK NO. 10 SPLIT	MS35338-100	BRONZE	
12	5	51808-064	WASHER - LOCK NO. 8 X .307 MAX. X .047 SPLIT	MS35338-99	BRONZE	
11	2	51806-034	WASHER - LOCK NO. 6 INT.	MS35333-68	BRONZE	
10	5	51712-104	WASHER - 3/8 X 11/64 X .032	AN961-8	BRASS	
9	9	51702-844	WASHER - 3/8 X 13/64 X .032	AN961-10	BRASS	
8	2	51206-644	SCREW - 6-32 X 3/4 RD. HD.	MS35214-29	BRASS	
7	9	50410-174	NUT - 10-32 X 5/16 X 9/64 HEX.		BRASS	
6	5	50408-034	NUT - 8-32 X 5/16 X 3/32 HEX.		BRASS	
5	1	15106-020	CONTACTOR ASSEMBLY - PRIMARY			
4	1	39529-001	OVERLAY NAME PLATE			
3	1	13717-001	PLATE - BASE COVER			
2	1	12531-003	SHIELD - TERMINAL			
1	1	16043-001	PLATE - NAME			

FIND NO	QTY REQD	PART OR IDENTIFYING NO	NOMENCLATURE OR DESCRIPTION	FSCM NO	DRAWING OR SPECIFICATION	MATERIAL OR NOTE
---------	----------	------------------------	-----------------------------	---------	--------------------------	------------------

UNLESS OTHERWISE SPECIFIED DIMENSIONS ARE IN INCHES TOLERANCES ON

2 PL DEC.	3 PL DEC.	ANGLES
± .03	± .010	± 1°

MATERIAL

DR BY	RCB	04/03/18
CHK BY	CB	04/03/18
ENGR	WR	04/03/22
MFG	MB	04/03/25
SIZE	CODE IDENT	
C	74063	

SCALE 1/1 SHEET

TE
 Hartman™ Division, 175 N. DIAMOND STREET MANSFIELD, OHIO 44902

CONTACTOR - TPDT NC
 093

DWG NO. B-138BH

REF TE P/N 1616028-1

单击下面可查看定价，库存，交付和生命周期等信息

[>>TE Connectivity\(泰科\)](#)