

REVISIONS			
REV	DESCRIPTION	DATE	APPROVED
D	REVISED PER ECN T-28195	03OCT00	TR

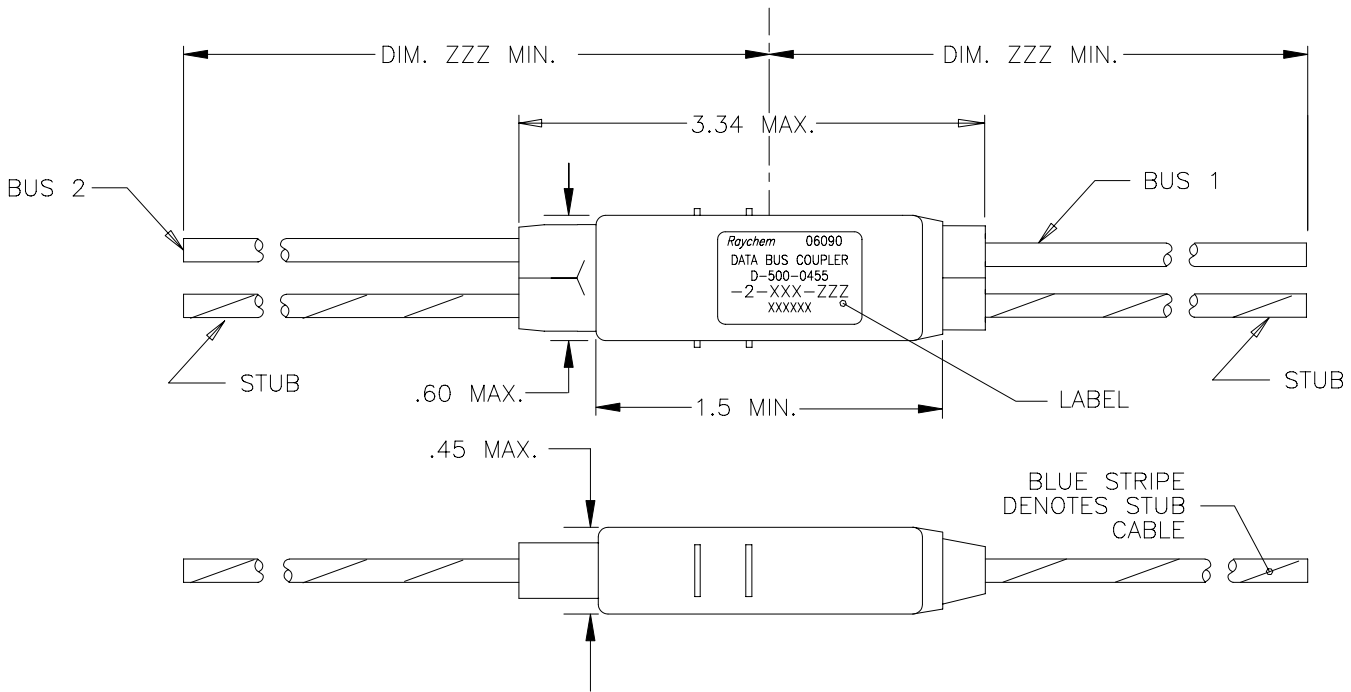

COMPONENT NUMBER	BUS CABLE	STUB CABLE
D-500-0455-2-612-ZZZ	10612-24-9	10612-24-96
D-500-0455-2-613-ZZZ	10613-24-9	10613-24-96
D-500-0455-2-614-ZZZ	10614-24-9	10614-24-96
D-500-0455-2-C26-ZZZ	7724C2664-9	7724C2664-96
D-500-0455-2-H06-ZZZ	7724H0664-9	7724H0664-96

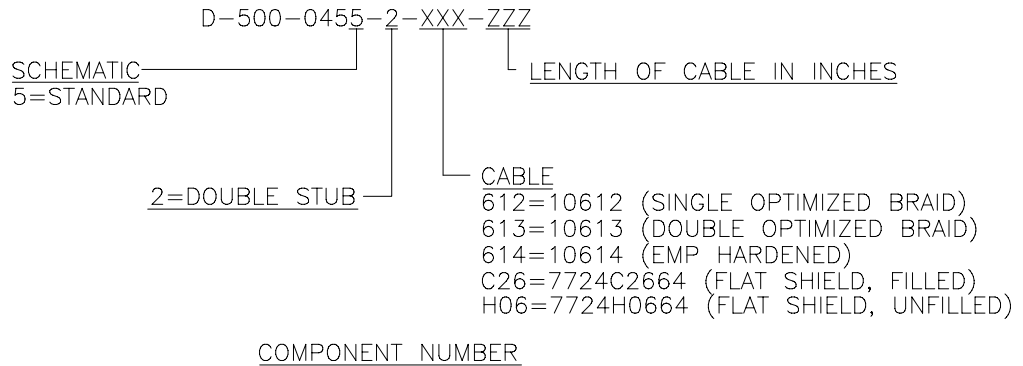

If this document is printed it becomes uncontrolled.
Check for the latest revision.

SPECIFICATION CONTROL DRAWING

UNLESS OTHERWISE SPECIFIED DIMENSIONS ARE IN INCHES. METRIC DIMENSIONS ARE IN BRACKETS. DECIMALS .XXX ± — { — mm } .XX ± — { — mm } ANGLES .X ± — WEIGHT — g { — lbs }	DRAWN	ZS.O.	3/31/98		Tyco Electronics Corporation 300 Constitution Drive Menlo Park, CA. 94025 U.S.A.		
	CHECKED						
	APPROVED			TITLE	TWO STUB IN-LINE DATA BUS MICRO COUPLER 04 SERIES STANDARD		
	APPROVED	M.HIGGY	3/31/98	CAD NAME	T28195A.dwg		
THIRD ANGLE PROJECTION			SIZE	CODE IDENT. NO.	DWG. NO.		
				06090	D-500-0455-2-XXX-ZZZ		
			Downloaded From	Oneyac.com			
			DO NOT SCALE THIS DRAWING			SHEET 1 OF 2	

1. MATERIAL AND FINISHES:
 - 1.1 INTERNAL COMPONENTS:
 - TRANSFORMER TO MIL-T-21038 AND MIL-STD-1553/B
 - RESISTORS TO PER MIL-R-39007/9, 57.6 OHMS
 - 1.2 SHIELDED CASE: ALUMINUM PER ASTM B 618, ALLOY A03560 COND. F. OR ASTM B211, ALLOY A92017.
 - 1.3 SEALED STRAIN RELIEF COVER: MODIFIED CROSS-LINKED ELASTOMER, BLACK, TO RAYCHEM SPECIFICATION RK-6713.
 - 1.4 CABLE (SEE CABLE TABULATION, SHEET 1). TO RAYCHEM SPECIFICATION 1200.
2. APPLICATION:
 - 2.1 THIS COUPLER IS DESIGNED TO BE INSTALLED INTO A DIGITAL MULTIPLEX ASSEMBLY MEETING THE REQUIREMENTS OF MIL-STD-1553B.
 - 2.1.1 FOR CABLE SPLICING USE FLEXIBLE SPLICE KIT D-150-9133.
 - 2.2 FOR NETWORK LAYOUT ASSISTANCE CONSULT RAYCHEM TECHNICAL SERVICES.
 - 2.3 CABLE BEND RADIUS PER MIL-W-5088 STATIC BEND: 5 x CABLE O.D. MIN.
DYNAMIC BEND: 10 x CABLE O.D. MIN.
3. TEMPERATURE:
 - 3.1 OPERATING TEMPERATURE: -65°C TO +150°C
4. PERFORMANCE SPECIFICATIONS:
 - 4.1 TRANSFORMER MEETS THE PERFORMANCE REQUIREMENTS OF MIL-STD-1553B.
 - 4.2 COUPLER WILL BE QUALIFIED TO RAYCHEM SPECIFICATION D-6020. QUALIFICATION PENDING.
5. WEIGHT:
 - 5.1 MAXIMUM WEIGHT WITHOUT CABLE: 15 GRAMS MAX.
6. ORDERING INFORMATION:

ORDER PER COMPONENT NUMBER. (SEE SHEET 1) AND DESIRED "ZZZ" CABLE LENGTH. SPLICE KITS TO BE ORDERED SEPARATELY.
SPECIFY CERTIFICATION OF CONFORMANCE REQUIREMENTS AS SEPARATE LINE ITEM.

TWO STUB COUPLER SCHEMATIC

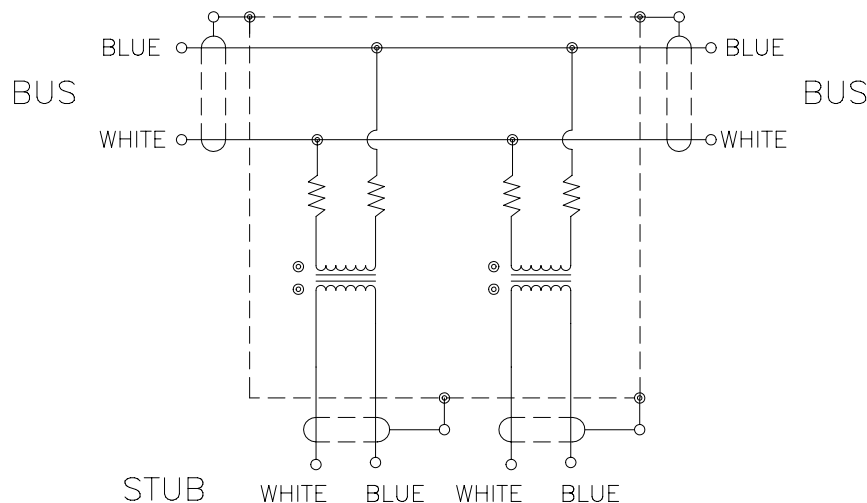

If this document is printed it becomes uncontrolled.
Check for the latest revision.

CAD NAME: T28195B	DRAWN	ZS.O.	3/31/98	SIZE	CODE IDENT. NO.	DWG. NO.	REV
	ISSUED	Downloaded From Oneyac.com		A	06090	D-500-0455-2-XXX-ZZZ	D
THIS DRAWING						SHEET 2 OF 2	

单击下面可查看定价，库存，交付和生命周期等信息

[>>TE Connectivity\(泰科\)](#)