

LOC	DIST	REV	DATE	BY	APP'D
AA	00				
A		RELEASED	21OCT2006	LAM	JW
B		ECO-07-001858	29JAN2007	LAM	JW
C		ECO-07-008800	18ARP2007	LAM	JW
D		ECR-08-019486	04AUG2008	A.L	S.Y

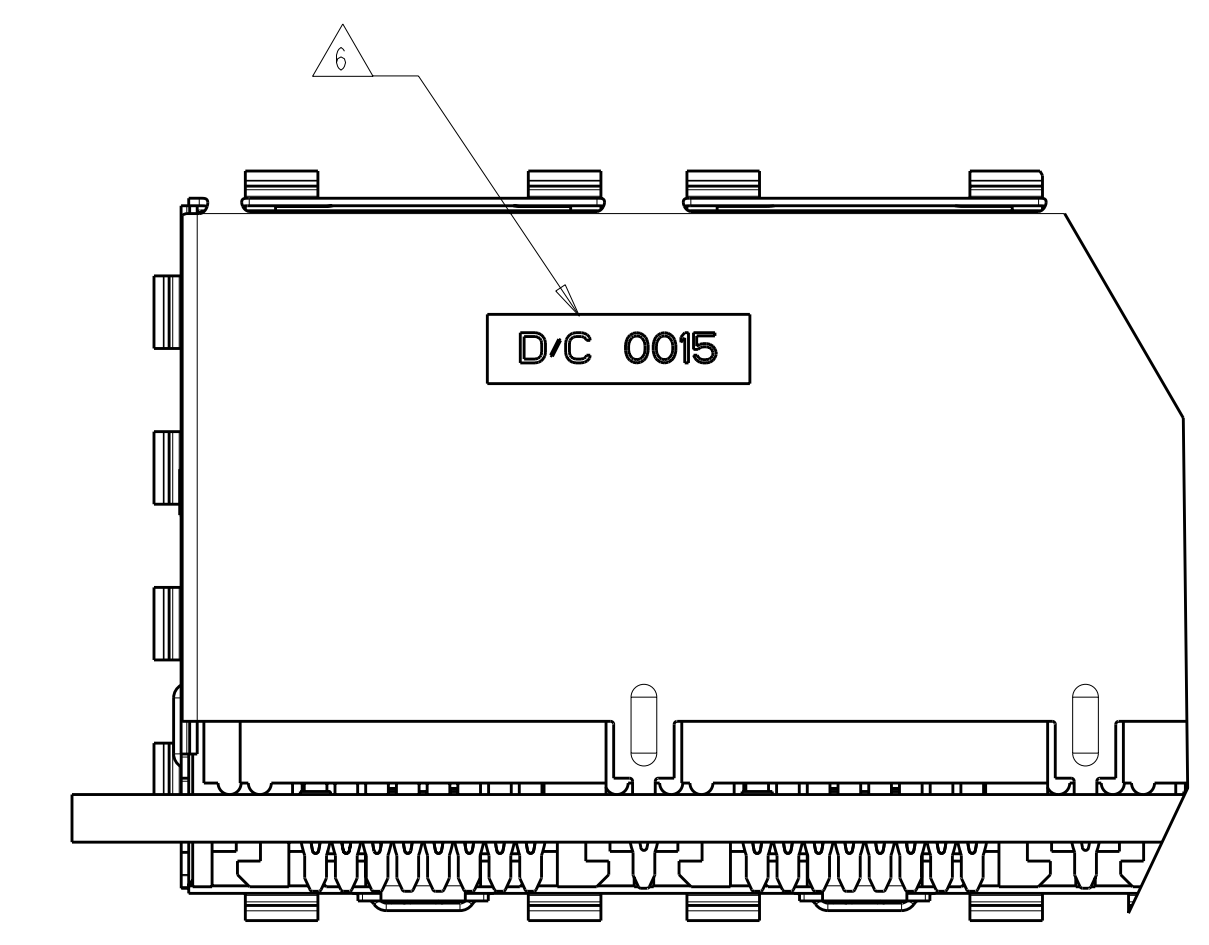

ATCA PANEL AND PRINTED CIRCUIT BOARD ASSEMBLY LAYOUT

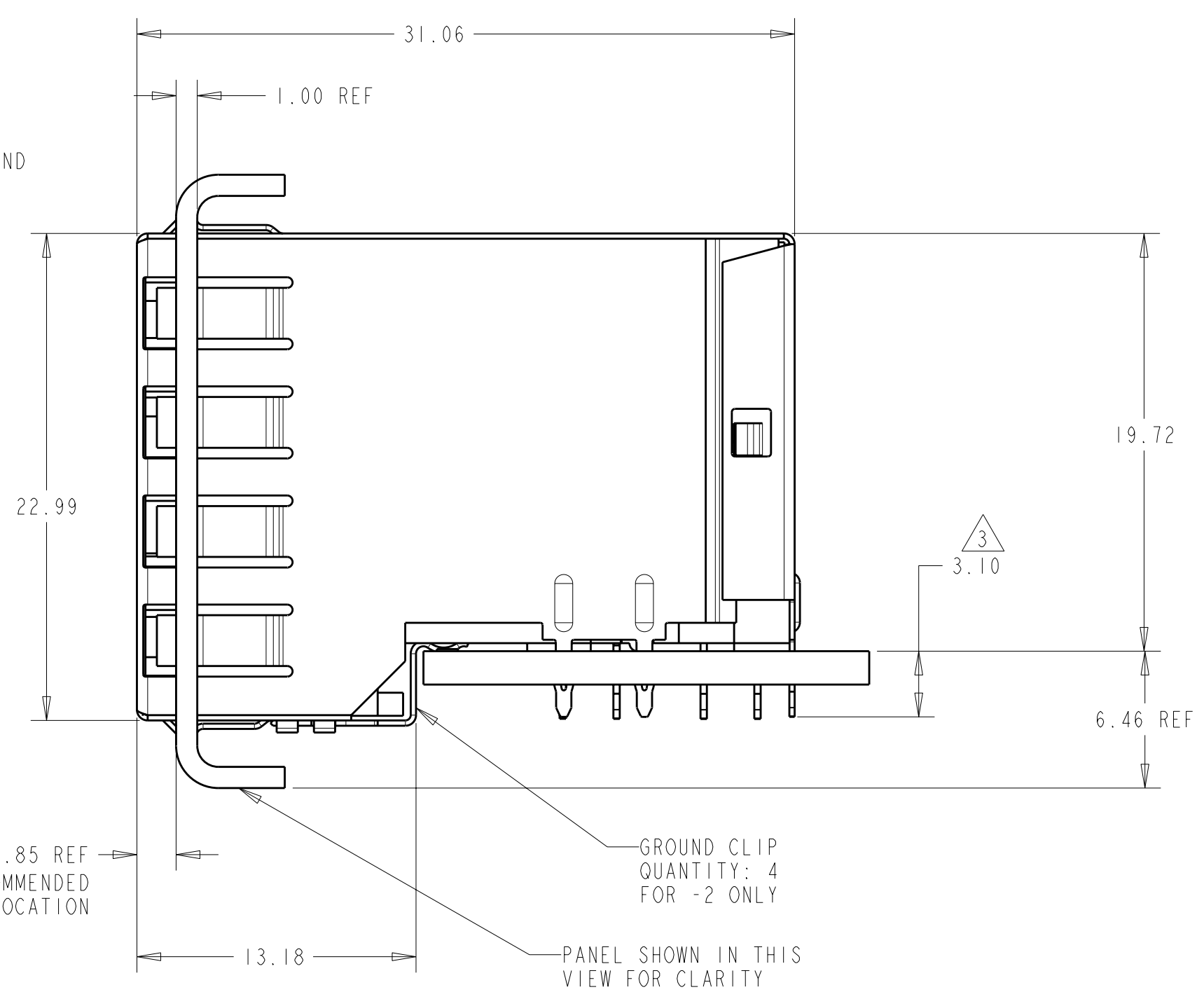
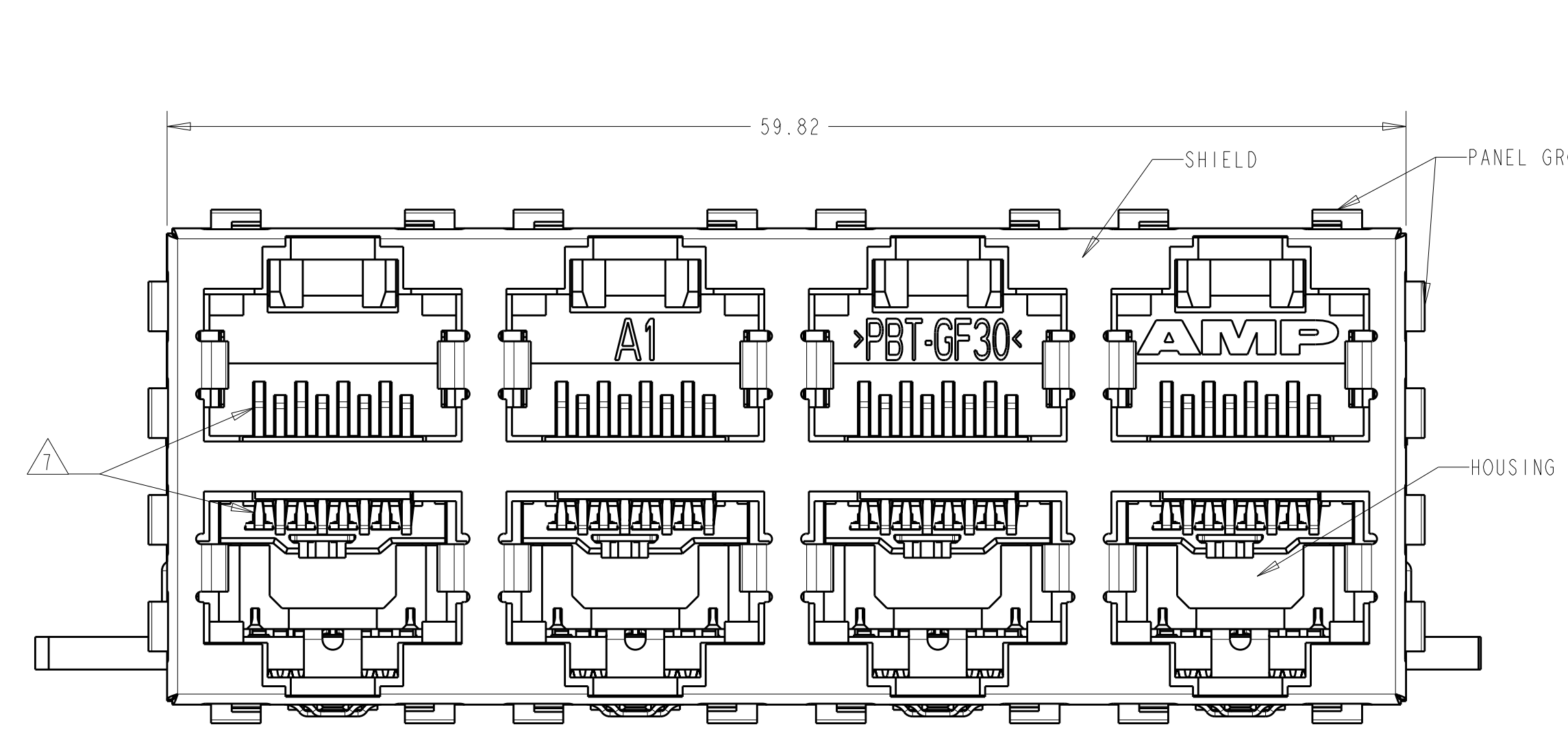
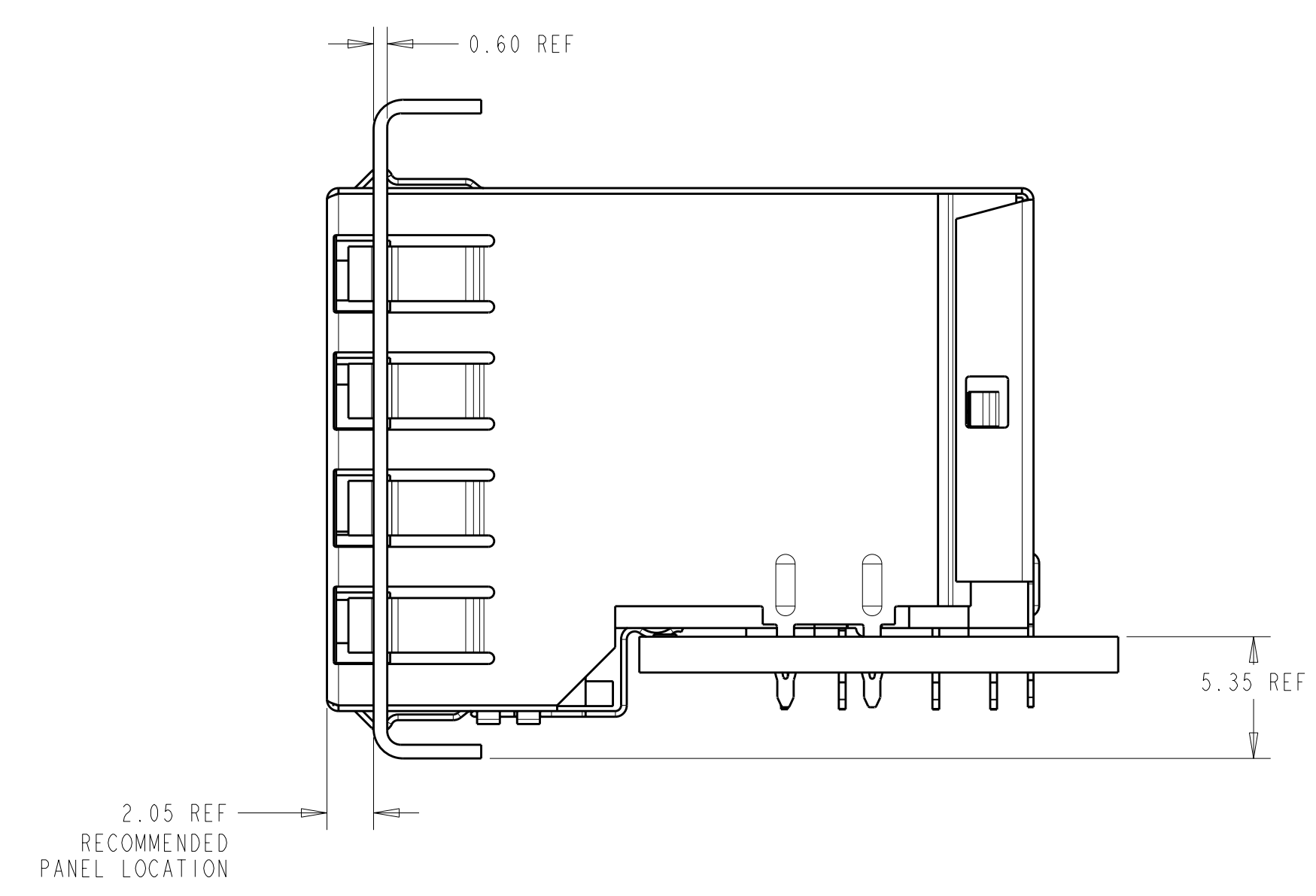

AMC PANEL AND PRINTED CIRCUIT BOARD ASSEMBLY LAYOUT

- MATERIAL:
 HOUSING: PBT POLYESTER, BLACK, UL 94V-0
 TERMINALS: 0.33 THICK PHOSPHOR BRONZE PLATED WITH 1.27µm MINIMUM THICK HARD GOLD IN LOCALIZED AREA AND 2.0µm MINIMUM THICK MATTE TIN IN COMPLIANT PIN TERMINAL AREA OVER 1.27µm MINIMUM THICK NICKEL UNDERPLATE
 SHIELD: 0.25 THICK COPPER ALLOY PLATED WITH 2.03µm MINIMUM TIN OVER 1.27 µm MINIMUM NICKEL
 GROUND CLIP: 0.25 THICK COPPER ALLOY PRE-PLATED WITH 2.03µm MINIMUM MATTE TIN OVER 1.27µm MINIMUM NICKEL
 - JACK CAVITY CONFORMS TO FCC RULES AND REGULATIONS, PART 68 SUBPART F.
- 3 MAXIMUM PIN LENGTH 3.40 FROM TOP SURFACE OF PC BOARD
 4 FINISHED PLATED THROUGH HOLE DIAMETER - ANNULAR RING DIAMETER 1.3 TO 1.5
 5 DATUMS AND BASIC DIMENSIONS ESTABLISHED BY CUSTOMER
 6 DATE CODE LOCATED ON REAR OF PART APPROXIMATELY AS SHOWN
 7 CONTACTS ARE NOT INTENDED TO BE ALIGNED WITH EACH OTHER

M DIM	DESCRIPTION	PART NUMBER
15.88	WITH GROUND CLIP	1888506-2 (SHOWN)
16.13	WITHOUT GROUND CLIP	1888506-1

DIMENSIONS: mm TOLERANCES UNLESS OTHERWISE SPECIFIED: 9 PLC ± 1 PLC ±0.13 5 PLC ± 4 PLC ± ANGLES ±1° FINISH -		DWN L.A.MAYER 21OCT2006 CHK J.WESTMAN 21OCT2006 APVD S.FLICKINGER 21OCT2006 PRODUCT SPEC 108-1854 APPLICATION SPEC 114-2160 WEIGHT - CUSTOMER DRAWING		Tyco Electronics Corporation Harrisburg, PA 17105-3608 NAME STACKED MOD JACK ASSEMBLY, 2 X 4, 8 POSN, RJ45, SHIELDED, PANEL GROUND, OFFSET, CAT 5 SIZE CAGE CODE DRAWING NO RESTRICTED TO A1 00779 C=1888506 SCALE 4:1 SHEET 1 OF 2 REV D	
--	--	---	--	--	--

LOC	DIST	REV	DATE	BY	APPD
AA	00	1			
		2			

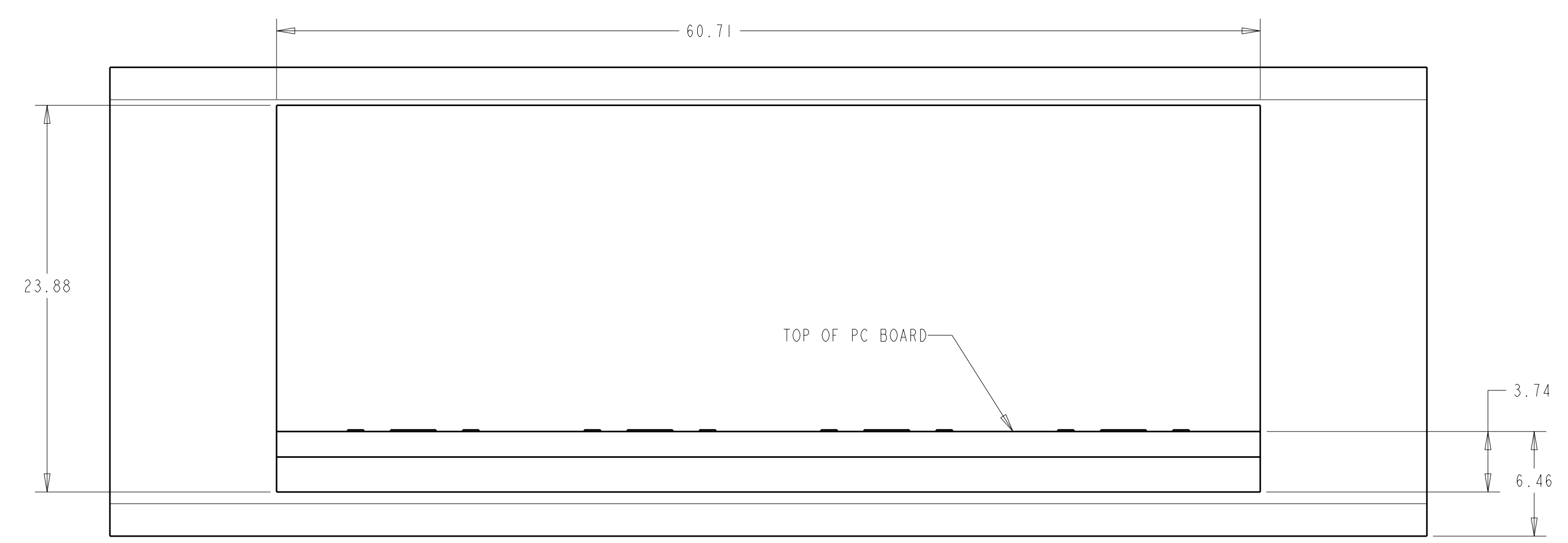

ATCA PANEL AND
PRINTED CIRCUIT BOARD LAYOUT

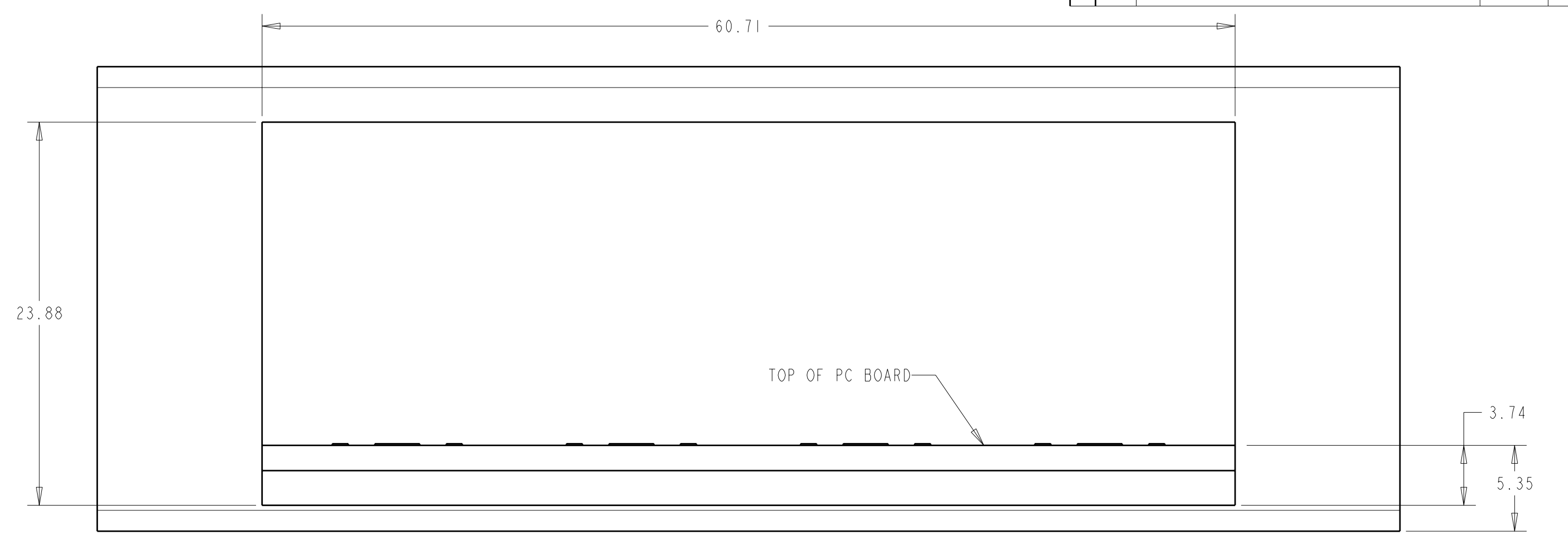

AMC PANEL AND
PRINTED CIRCUIT BOARD LAYOUT

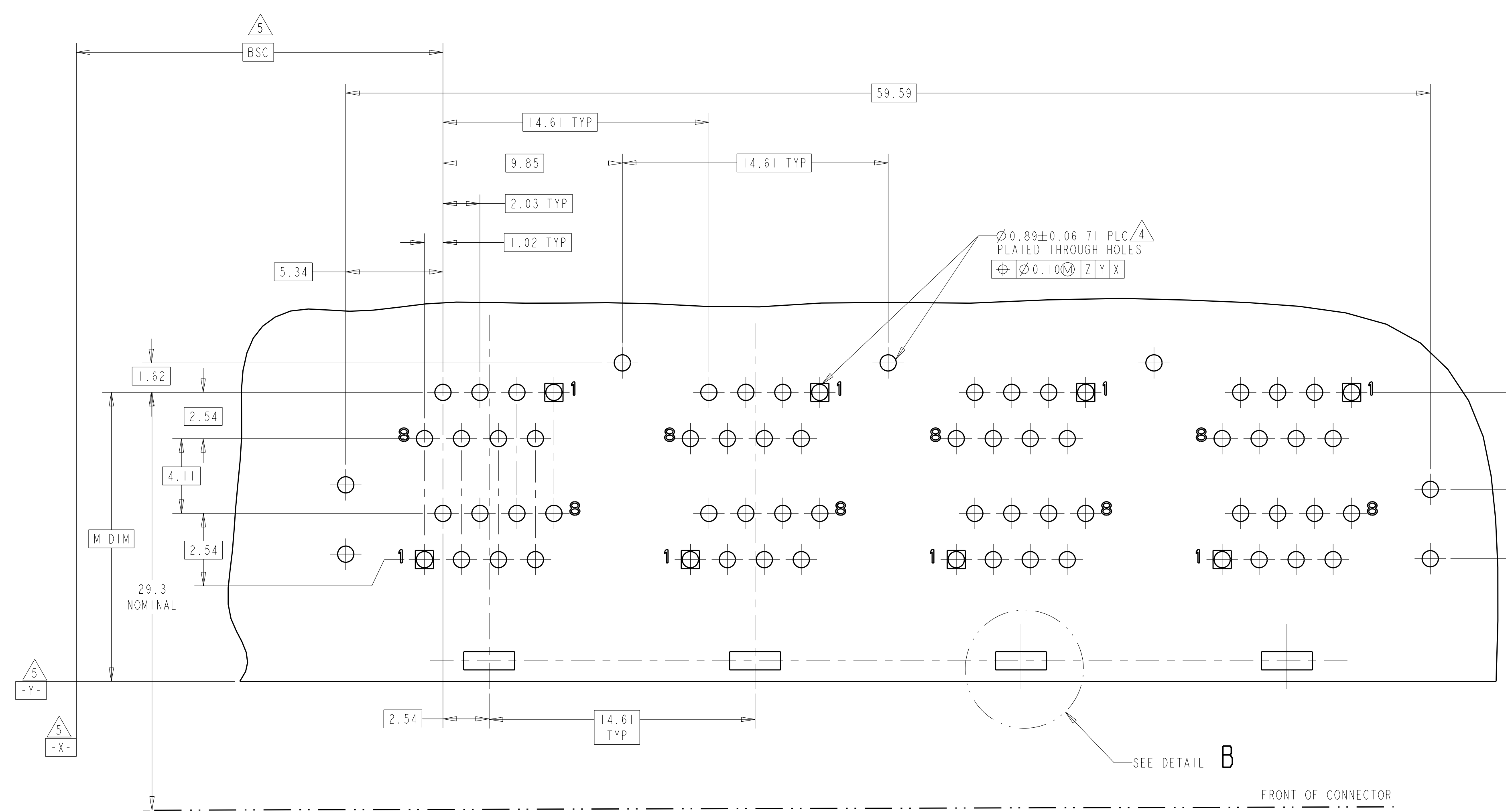

PC BOARD LAYOUT
(COMPONENT SIDE)

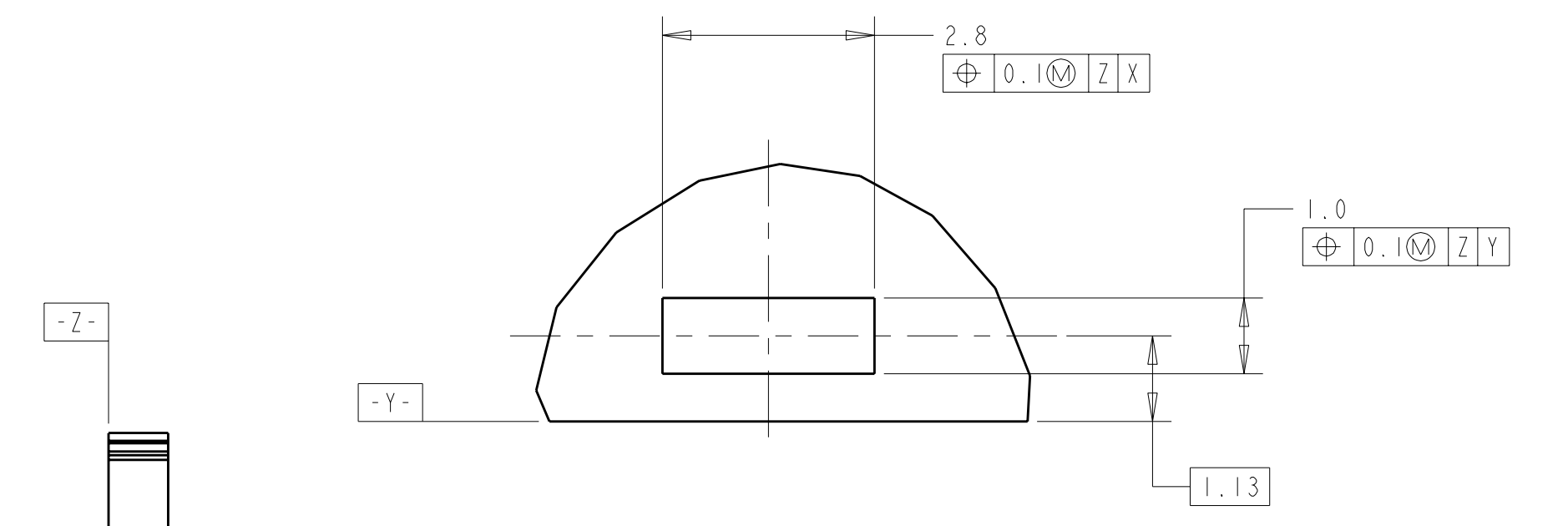

DETAIL B
SCALE 12:1
PLATED PADS REQUIRED FOR
1888506-2 (PRODUCT WITH
GROUNDING CLIP)
4 PLC

DIMENSIONS: mm 		TOLERANCES UNLESS OTHERWISE SPECIFIED: 9 PLC ± 1 PLC ±0.13 5 PLC ± 4 PLC ± ANGLES ±1° FINISH -		DWN L.A.MAYER 21OCT2006 CHK J.WESTMAN 21OCT2006 APVD S.FLICKINGER 21OCT2006 PRODUCT SPEC 108-1854 APPLICATION SPEC 114-2160 WEIGHT - CUSTOMER DRAWING		Tyco Electronics Tyco Electronics Corporation Harrisburg, PA 17105-3608 NAME STACKED MOD JACK ASSEMBLY, 2 X 4, 8 POSN, RJ45, SHIELDED, PANEL GROUND, OFFSET, CAT 5 SIZE CAGE CODE DRAWING NO RESTRICTED TO A1100779 C=1888506 - SCALE 1:1 SHEET 2 OF 2 REV D	
-----------------------	--	--	--	---	--	--	--

单击下面可查看定价，库存，交付和生命周期等信息

[>>TE Connectivity\(泰科\)](#)