

REVISIONS					
P	LTR	DESCRIPTION	DATE	DWN	APVD
G		REVISED PER ECR-20-101152	02SEP2021	PJ	VS

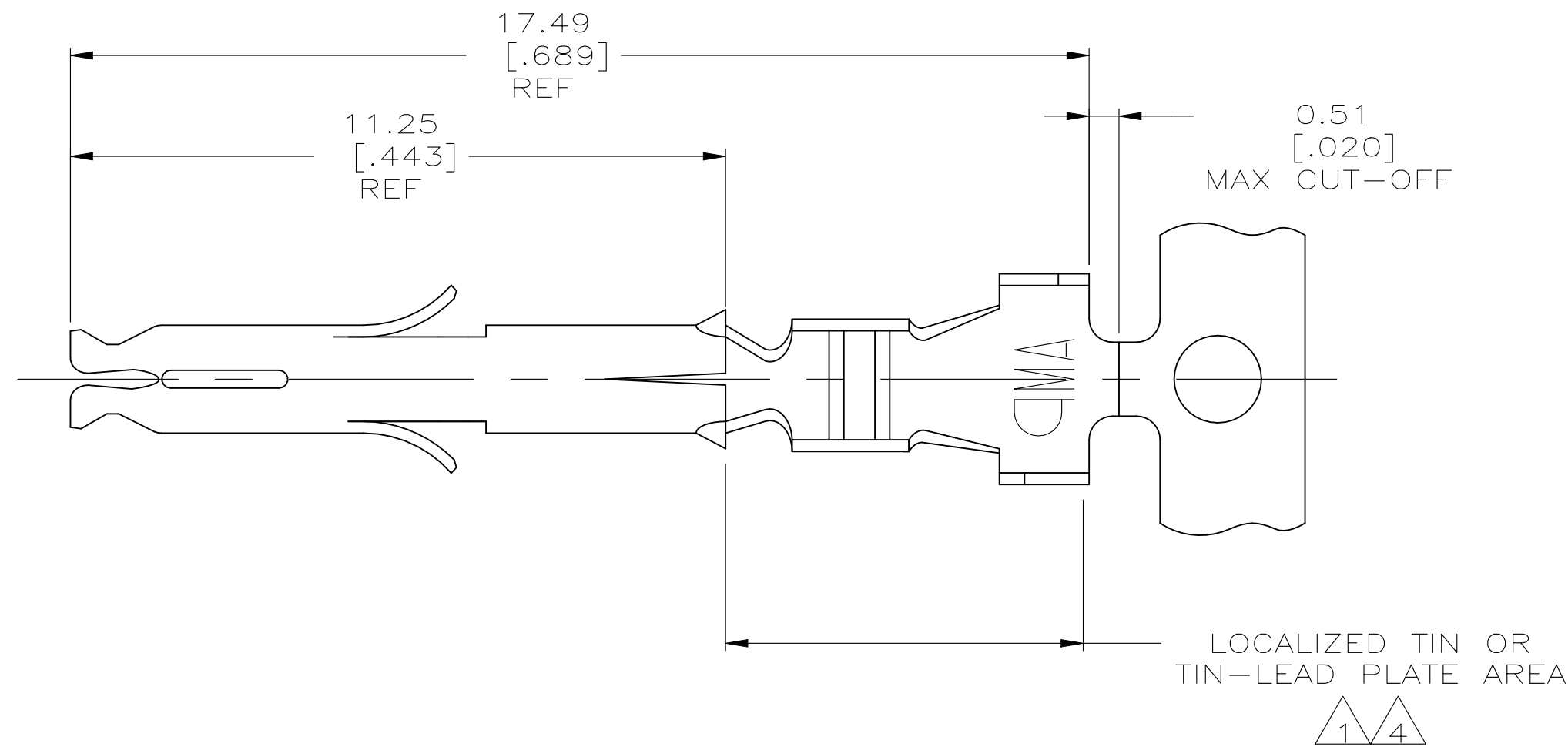

- 1. 0.00076 [.000030] MIN GOLD PER IN LOCALIZED GOLD PLATE AREA AND 0.00254-0.00635 [.000100-.000250] BRIGHT TIN-LEAD PER IN LOCALIZED TIN-LEAD PLATE AREA OVER 0.00127 [.000050] MIN NICKEL.
- 2. WIRE RANGE: 0.5-1.4MM² (20-16 AWG).
- 3. INSULATION RANGE: 2.01-3.20[.079-.126] DIA.
- 4. 0.00076 [.000030] MIN GOLD PER IN LOCALIZED GOLD PLATE AREA AND 0.00254-0.00635 [.000100-.000250] MATTE TIN IN LOCALIZED TIN PLATE AREA OVER 0.00127 [.000050] MIN NICKEL.

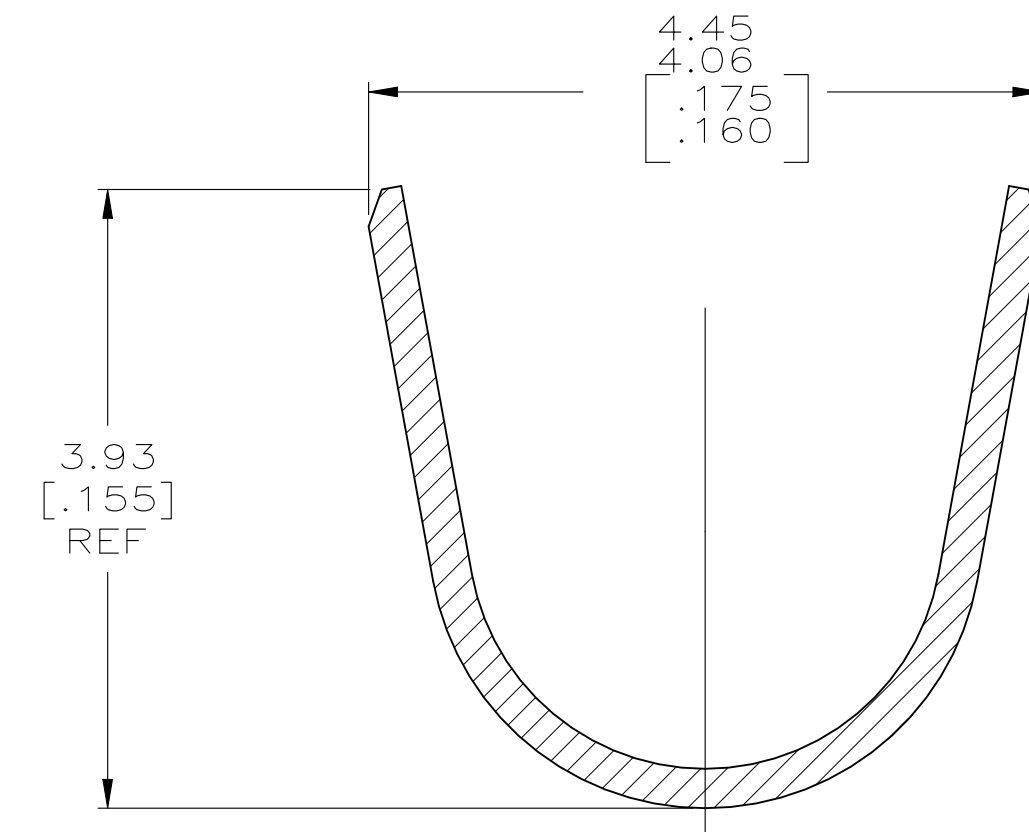
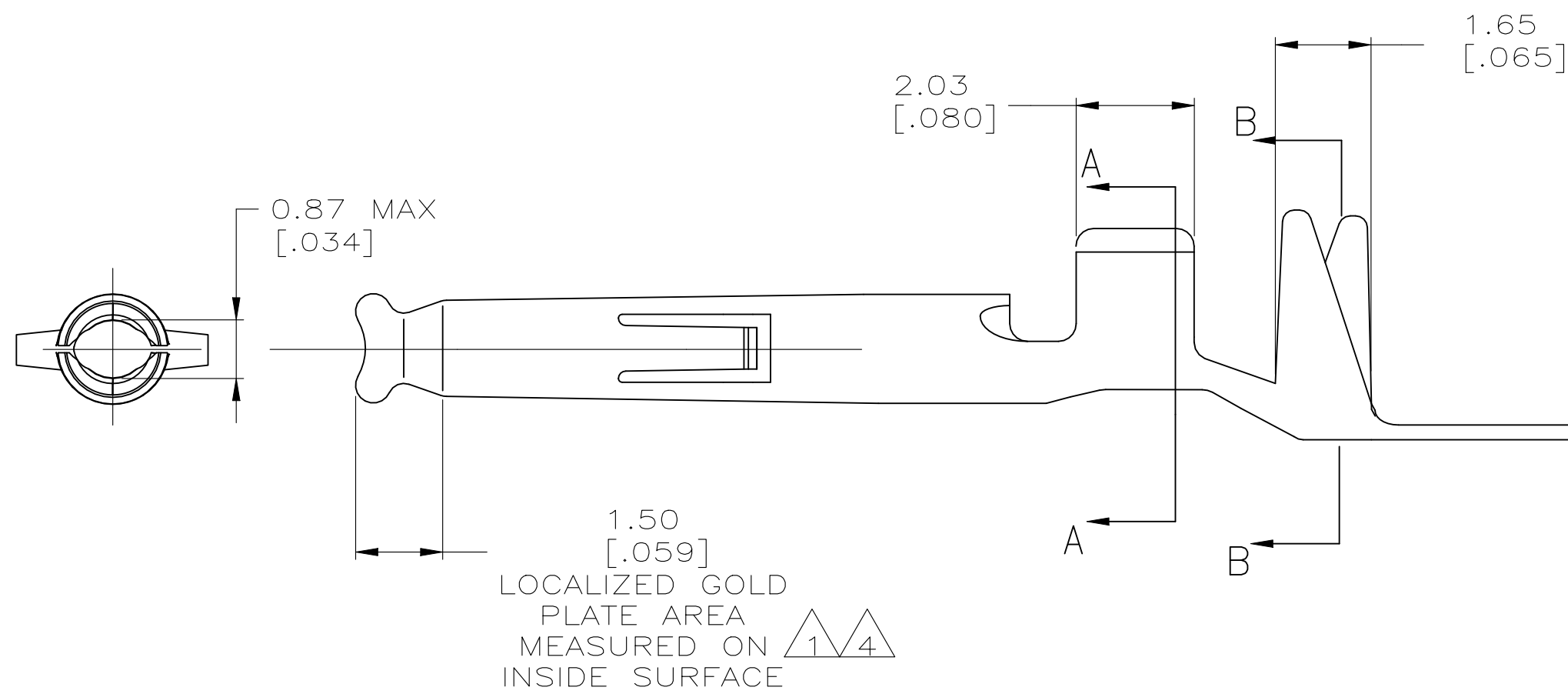

SECTION B-B
SCALE 20:1

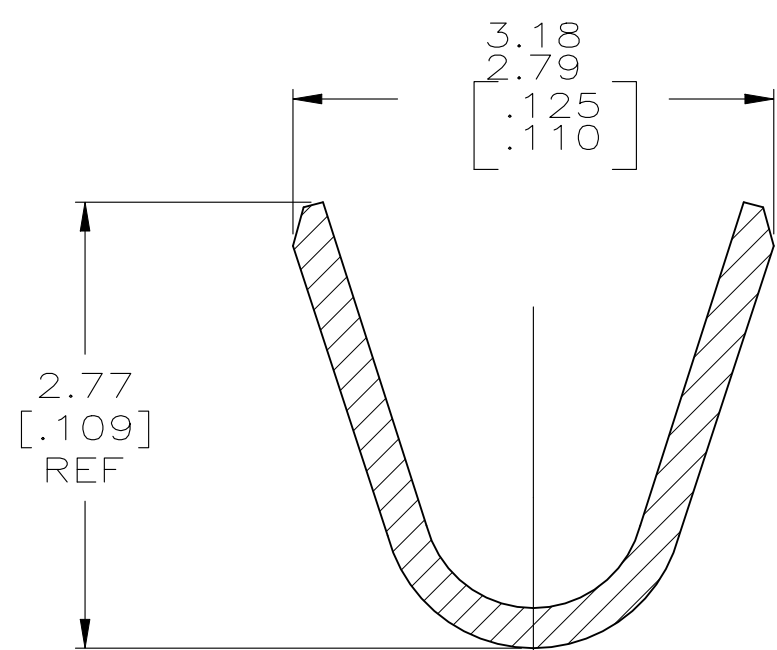

SECTION A-A
SCALE 20:1

SUPERCEDED BY 1-794407-0

FINISH	MATERIAL	PART NUMBER
4	0.20 [.008] PH BRZ	1-794407-1
4	0.20 [.008] BRASS	1-794407-0
1	0.25 [.010] PHOS BRONZE	794407-6
PRE-TIN	0.25 [.010] PHOS BRONZE	794407-4
1	0.25 [.010] BRASS	794407-3
PRE-TIN	0.25 [.010] BRASS	794407-1

THIS DRAWING IS A CONTROLLED DOCUMENT.		DWN S. HOOVER 10JAN03	TE TE Connectivity	
DIMENSIONS: mm [INCHES]		CHK C. JONES 10JAN03		
TOLERANCES UNLESS OTHERWISE SPECIFIED:		APVD C. JONES 10JAN03	NAME SOCKET, MINI UNIVERSAL MATE-N-LOK(TM)	
0 PLC ± -	1 PLC ± -	PRODUCT SPEC 108-5142	SIZE A2	CAGE CODE 00779
2 PLC ± 0.13[.005]	3 PLC ± -	APPLICATION SPEC 114-16017	DRAWING NO C=794407	RESTRICTED TO -
4 PLC ± -	ANGLES ± -	WEIGHT 0.000000	SCALE 10:1	SHEET 1 of 1
MATERIAL -	FINISH -	CUSTOMER DRAWING	REV G	

单击下面可查看定价，库存，交付和生命周期等信息

[>>TE Connectivity\(泰科\)](#)