

4

3

THIS DRAWING IS UNPUBLISHED. RELEASED FOR PUBLICATION
© COPYRIGHT BY TYCO ELECTRONICS CORPORATION, ALL RIGHTS RESERVED.

LOC	DIST	REVISIONS					
		P	LTR	DESCRIPTION	DATE	DWN	APVD
DS			A	RELEASED	26, JUN, 09	DR.	HG

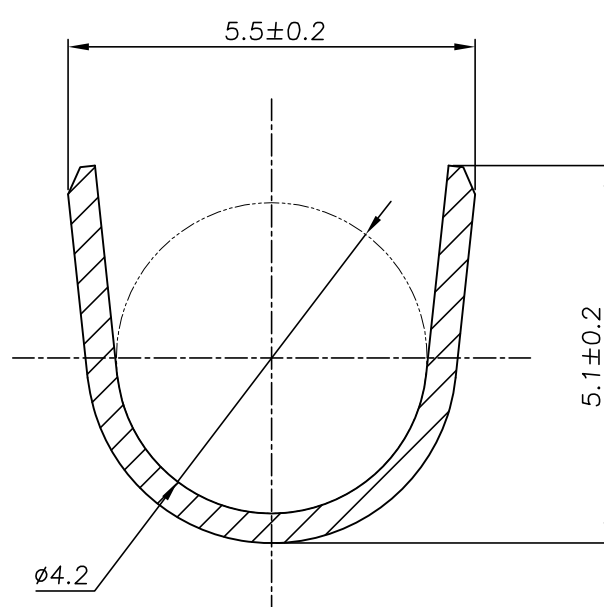
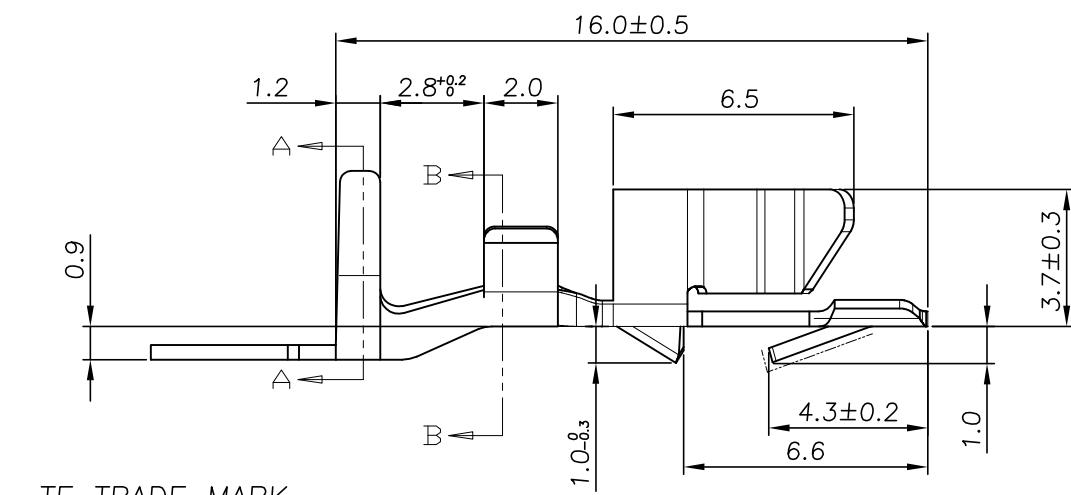
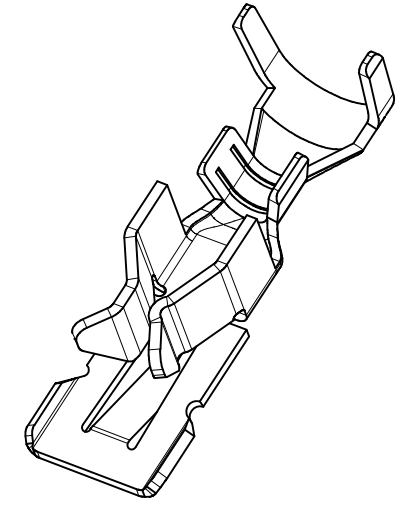
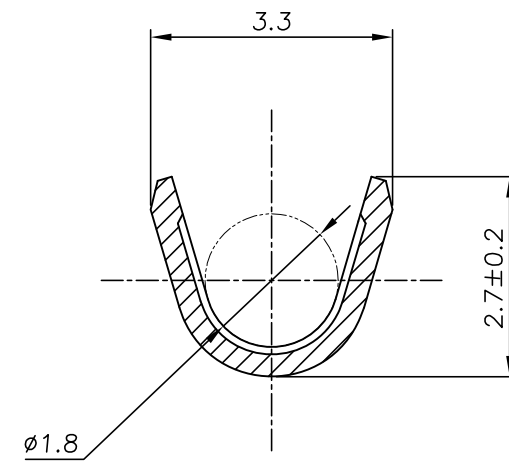
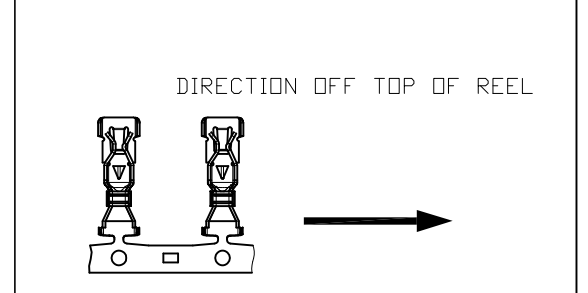
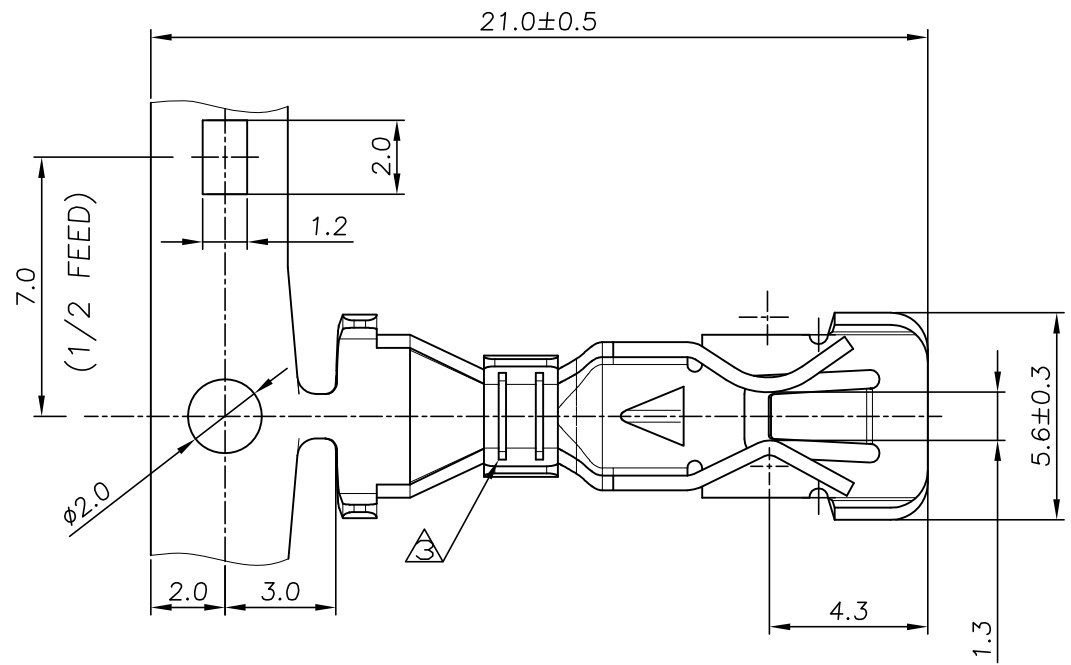

NOTE
 1. GENERAL TOLERANCE : ±0.3, ±2°
 2. WIRE SIZE AVS 0.5mm²
 3. TWO SERRATIONS CENTERED IN WIRE BARREL.

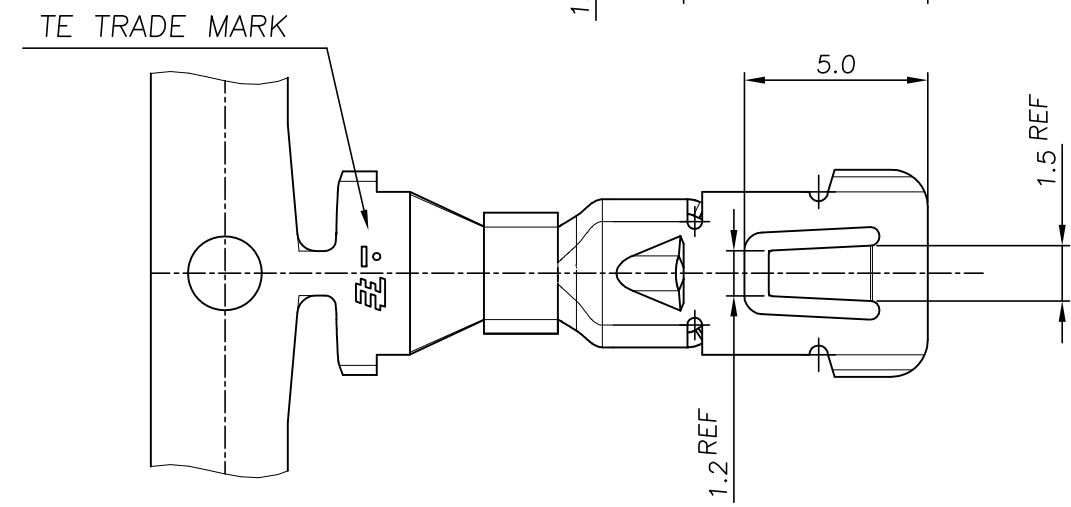

FINISH		Cu Alloy 0.40THK.		2005207-1	
MATERIAL		MATERIAL		PART NUMBER	
DWN : DR. GOD		Tyco Electronics		Tyco Electronics Kyungsan, Korea	
CHK : JW JUNG		NAME		C200/NB7 B/SOCKET TML	
APVD : HG CHD		PRODUCT SPEC		---	
APPLICATION SPEC		---		---	
WEIGHT		A3 00779		C- 2005207	
CUSTOMER DRAWING		SCALE 5/1		SHEET 1 OF 1	
SCALE 5/1		SHEET 1 OF 1		REV A	

DIMENSIONS: mm		TOLERANCES UNLESS OTHERWISE SPECIFIED:	
3rd ANGLE PROJECTION		±	
MATERIAL		FINISH	
SEE TABLE		-	

单击下面可查看定价，库存，交付和生命周期等信息

[>>TE Connectivity\(泰科\)](#)