

REVISIONS					
P	LTR	DESCRIPTION	DATE	DWN	APVD
	G	REV / 0G10-0041-99	10MAR99	MLE	MS
	G1	REVISED PER ECO-17-014333	11OCT2017	RS	DR

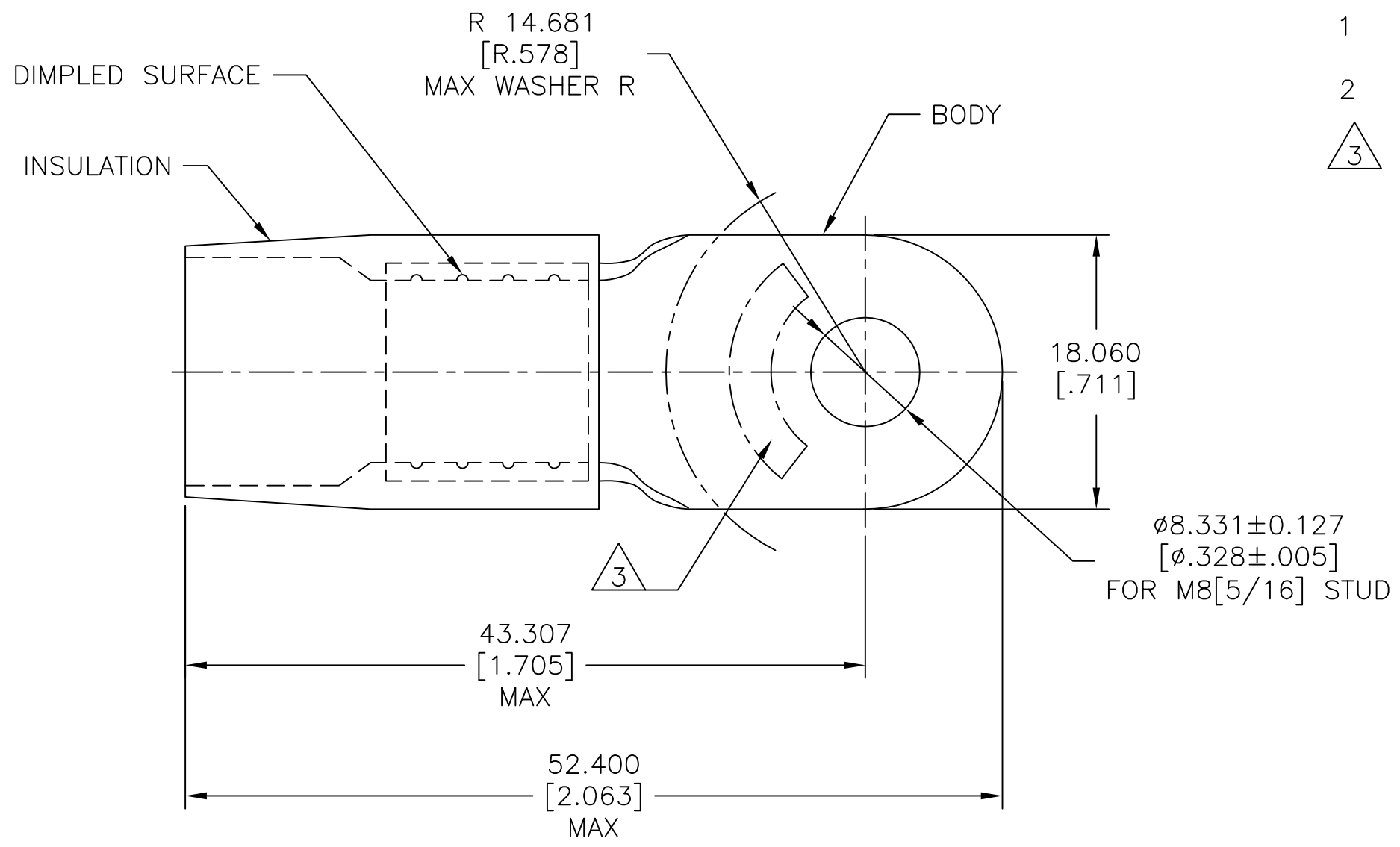

- 1 BODY MATERIAL THK 1.448±0.051[.057±.002]
- 2 FOR ø12.014[ø.473] MAX WIRE INS.
- △ 3 STAMP AMP 2\* APPROX AS SHOWN.

50	LOOSE PC	324112
QTY	PACKAGE TYPE	PART NO

AMP INCORPORATED  
 CUSTOMER SERVICE SYSTEMS

THIS DRAWING IS A CONTROLLED DOCUMENT.

DWN	S.S. GOULDEN	6-21-93
CHK	R. ELLIS	6-21-93
APVD	B. BARE	6-21-93
PRODUCT SPEC	-	
APPLICATION SPEC	-	
WEIGHT	-	



NAME: TERMINAL, RING TONGUE, TERMINYL™  
 WIRE SIZE, 2 AWG

FOR ADDITIONAL PRODUCT INFORMATION OR COPIES OF DRAWINGS AND TECHNICAL DOCUMENTS	PRODUCT INFORMATION CENTER 1-800-522-6752	MAX RECOMMENDED OPERATING TEMPERATURE: 105°C [221°F]
FOR APPLICATION TOOLING INFORMATION	TOOLING ASSISTANCE CENTER 1-800-722-1111	
FOR ORDER ENTRY	1-800-526-5142	WIRE CROSS SECTIONAL AREA RANGE, 26.7-42.4mm²[52,600-83,700] STRANDED

DIMENSIONS: mm [INCHES]	TOLERANCES UNLESS OTHERWISE SPECIFIED:
	0 PLC ± -
	1 PLC ± -
	2 PLC ± -
	3 PLC ± 0.127[.005]
	4 PLC ± -
	ANGLES ± -
MATERIAL	FINISH
BODY: COPPER PER ASTM B-152	BODY: TIN PLATE PER ASTM B 545
INSULATION: NYLON ASTM D4066 TYPE I	INSULATION: COLOR-RED

SIZE	CAGE CODE	DRAWING NO	RESTRICTED TO
A3	00779	324112	-
CUSTOMER DRAWING		SCALE	SHEET
		NTS	1 OF 1
		REV	G1

单击下面可查看定价，库存，交付和生命周期等信息

[>>TE Connectivity\(泰科\)](#)