

THIS DRAWING IS UNPUBLISHED. RELEASED FOR PUBLICATION

© COPYRIGHT - By - ALL RIGHTS RESERVED.

PROJECT	PRJ-16-000909157
PART NO.	X-2308341-X
DESCRIPTION	FULL METAL HOODS SIZE 2
CUSTOMER	GENERAL MARKET

REVISIONS					
P	LTR	DESCRIPTION	DATE	DWN	APVD
	A1	REVISED PER ECR-16-013123	19SEP2016	KK	GG

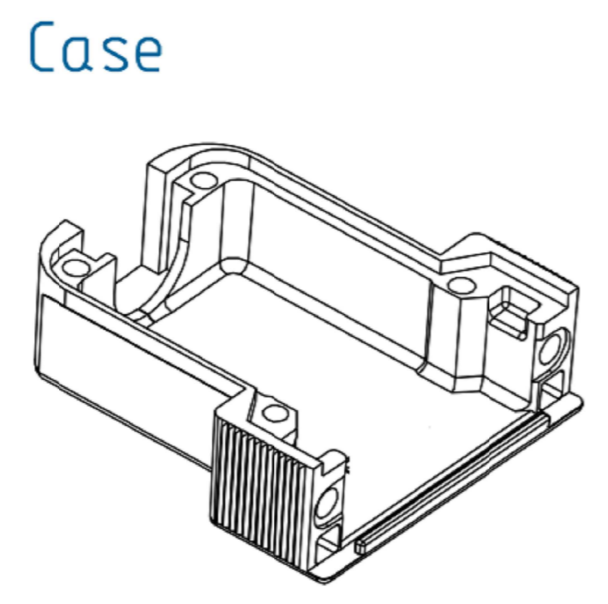
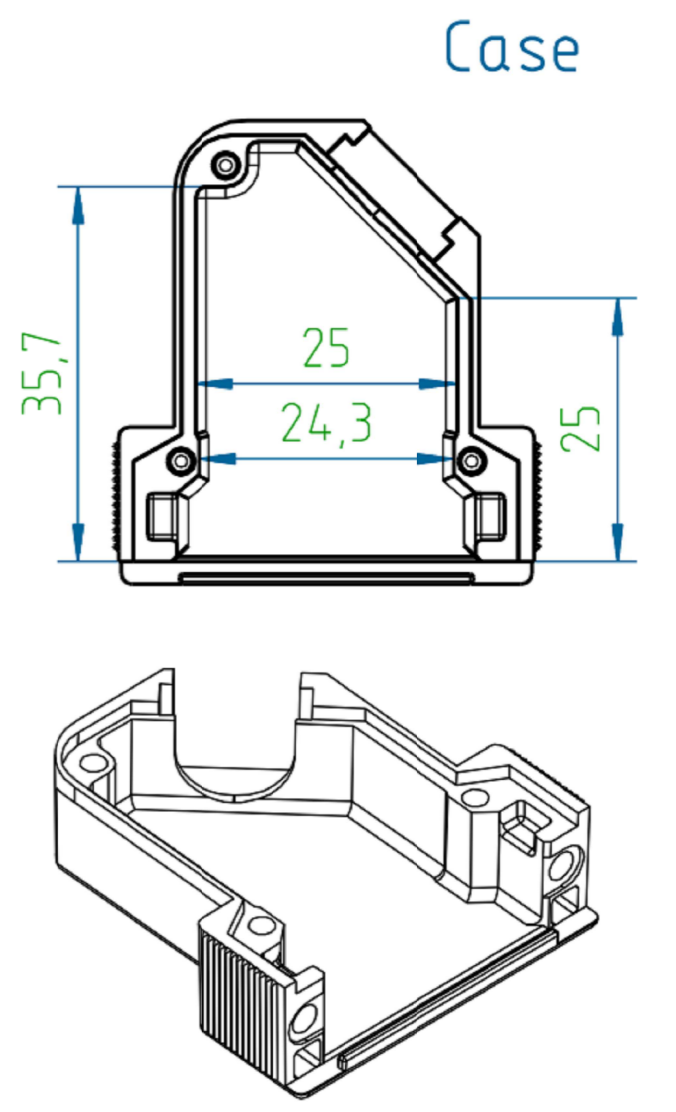
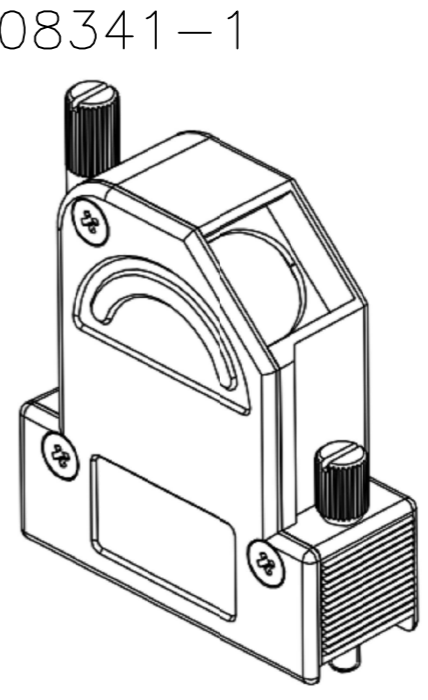
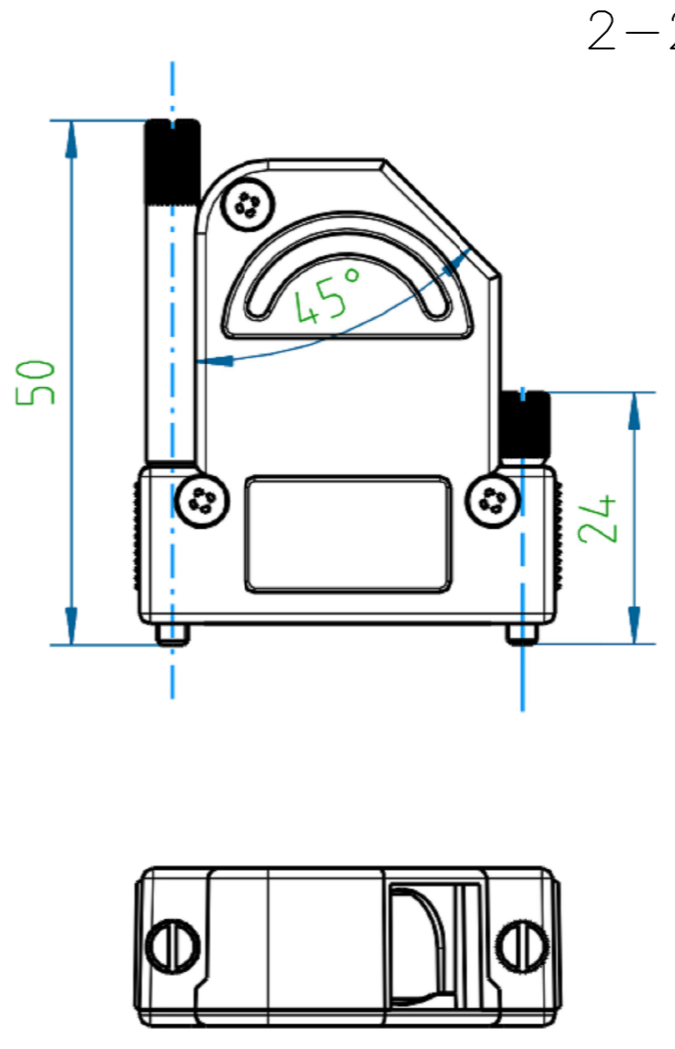
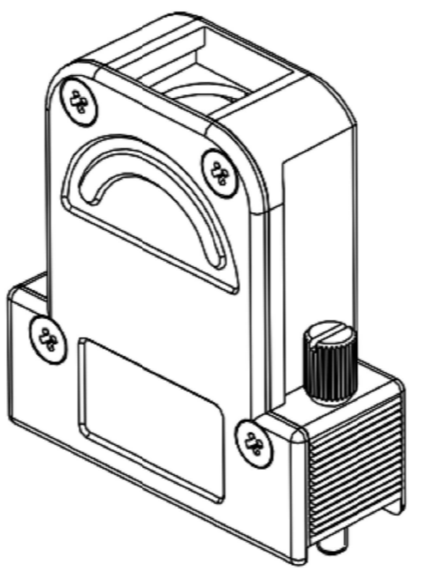
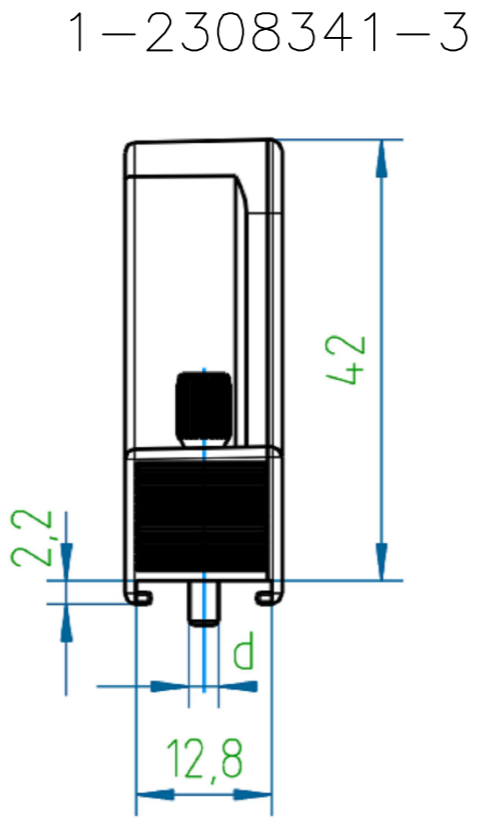
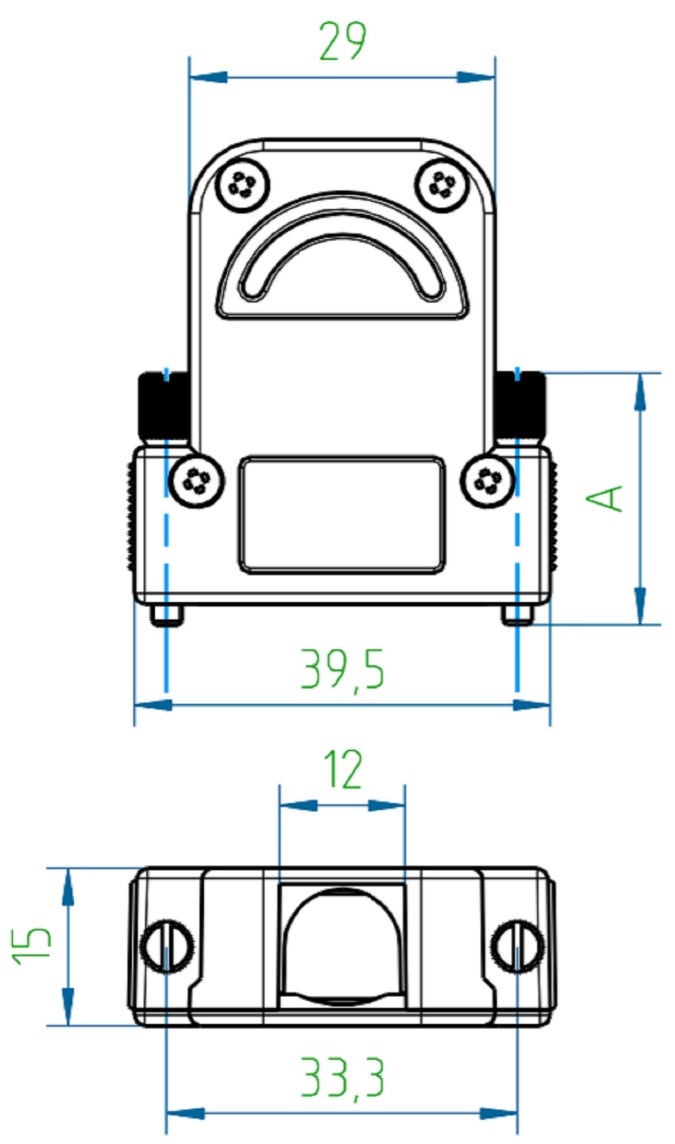

NOTES:

- FINISH:  
1-2308341-1 TO 2-2308341-2- CASE RAW  
2-2308341-3 TO 3-2308341-4 - CASE NICKEL-PLATED
- LOCKING SCREWS: NICKEL-PLATED  
OTHER SCREWS: ZINC-PLATED
- TEMPERATURE RANGE: -40°C TO +90°C
- CABLE DIAMETER WITH EXTERNAL DIAMETER CABLE CLAMP: 4-14 mm.
- STRAND DIAMETER OF CRIMP FLANGE: 2.7-8.7 mm.

THIS DRAWING IS A CONTROLLED DOCUMENT.		DWN KIRAN K 02AUG2016	TE Connectivity	
DIMENSIONS: mm		CHK GUNASEKHAR G 02AUG2016		
TOLERANCES UNLESS OTHERWISE SPECIFIED: DIN ISO 2768-m DIN 16901 130B		APVD GUNASEKHAR G 02AUG2016	NAME FULL METAL HOODS SIZE 2	
0 PLC ± -		PRODUCT SPEC	SIZE CAGE CODE DRAWING NO RESTRICTED TO	
1 PLC ± -		APPLICATION SPEC	A2 00779 G=2308341 -	
2 PLC ± -		WEIGHT	SCALE NTS SHEET 1 of 2 REV A1	
3 PLC ± -		CUSTOMER DRAWING		
4 PLC ± -				
ANGLES ± -				
FINISH -				

THIS DRAWING IS UNPUBLISHED. RELEASED FOR PUBLICATION  
 © COPYRIGHT - By - ALL RIGHTS RESERVED.

REVISIONS					
P	LTR	DESCRIPTION	DATE	DWN	APVD
-	-	SEE SHEET 1	-	-	-

PART NO.	DESCRIPTION	PART NO.	DESCRIPTION	SUB-PART NO.	DESCRIPTION					
-	-	2-2308341-2	FULL METAL HOODS SIZE2-12	1-2308334-6	1-2308334-4	LOCKING SCREW (M3 LONG KNURLED)	LOCKING SCREW (M3 SHORT KNURLED)	S OVER	M3	51
-	-	2-2308341-1	FULL METAL HOODS SIZE2-11	1-2308334-5	1-2308334-3	LOCKING SCREW (4-40 UNC LONG KNURLED)	LOCKING SCREW (4-40 UNC SHORT KNURLED)		4-40 UNC	51
1-2308341-6	FULL METAL HOODS SIZE2-6	-	-	1-2308334-6		LOCKING SCREW (M3 LONG KNURLED)		50.0	M3	55
1-2308341-5	FULL METAL HOODS SIZE2-5	-	-	1-2308334-5		LOCKING SCREW (4-40 UNC LONG KNURLED)		50.0	4-40 UNC	55
1-2308341-4	FULL METAL HOODS SIZE2-4	2-2308341-0	FULL METAL HOODS SIZE2-10	1-2308334-4		LOCKING SCREW (M3 SHORT KNURLED)		24.0	M3	47
1-2308341-3	FULL METAL HOODS SIZE2-3	1-2308341-9	FULL METAL HOODS SIZE2-9	1-2308334-3		LOCKING SCREW (4-40 UNC SHORT KNURLED)		24.0	4-40 UNC	47
1-2308341-2	FULL METAL HOODS SIZE2-2	1-2308341-8	FULL METAL HOODS SIZE2-8	1-2308334-2		LOCKING SCREW (M3 W/SPRING WASHER)		20.7	M3	46
1-2308341-1	FULL METAL HOODS SIZE2-1	1-2308341-7	FULL METAL HOODS SIZE2-7	1-2308334-1		LOCKING SCREW (4-40 UNC W/SPRING WASHER)		20.7	4-40 UNC	46
VERSION 180*		VERSION 135*				LOCKING SCREWS		A	d	WEIGHT, g
PART NO. (CASE RAW)										

PART NO.	DESCRIPTION	PART NO.	DESCRIPTION	SUB-PART NO.	DESCRIPTION					
-	-	3-2308341-4	FULL METAL HOODS SIZE2-24	1-2308334-6	1-2308334-4	LOCKING SCREW (M3 LONG KNURLED)	LOCKING SCREW (M3 SHORT KNURLED)	S OVER	M3	51
-	-	3-2308341-3	FULL METAL HOODS SIZE2-23	1-2308334-5	1-2308334-3	LOCKING SCREW (4-40 UNC LONG KNURLED)	LOCKING SCREW (4-40 UNC SHORT KNURLED)		4-40 UNC	51
2-2308341-8	FULL METAL HOODS SIZE2-18	-	-	1-2308334-6		LOCKING SCREW (M3 LONG KNURLED)		50.0	M3	55
2-2308341-7	FULL METAL HOODS SIZE2-17	-	-	1-2308334-5		LOCKING SCREW (4-40 UNC LONG KNURLED)		50.0	4-40 UNC	55
2-2308341-6	FULL METAL HOODS SIZE2-16	3-2308341-2	FULL METAL HOODS SIZE2-22	1-2308334-4		LOCKING SCREW (M3 SHORT KNURLED)		24.0	M3	47
2-2308341-5	FULL METAL HOODS SIZE2-15	3-2308341-1	FULL METAL HOODS SIZE2-21	1-2308334-3		LOCKING SCREW (4-40 UNC SHORT KNURLED)		24.0	4-40 UNC	47
2-2308341-4	FULL METAL HOODS SIZE2-14	3-2308341-0	FULL METAL HOODS SIZE2-20	1-2308334-2		LOCKING SCREW (M3 W/SPRING WASHER)		20.7	M3	46
2-2308341-3	FULL METAL HOODS SIZE2-13	2-2308341-9	FULL METAL HOODS SIZE2-19	1-2308334-1		LOCKING SCREW (4-40 UNC W/SPRING WASHER)		20.7	4-40 UNC	46
VERSION 180*		VERSION 135*				LOCKING SCREWS		A	d	WEIGHT, g
PART NO. (CASE Ni-PLATED)										

NOTE:

- \* CRIMP FLANGE PN \*-2308349-\* TO BE ORDERED SEPARATELY.
- \* CRIMP BARREL TO BE USED IN COMBINATION WITH THE FLANGE PN \*-2308350-\* TO BE ORDERED SEPARATELY.
- \* CABLE CLAMP SCREW VERSION PN \*-2308272-\* TO BE ORDERED SEPARATELY.

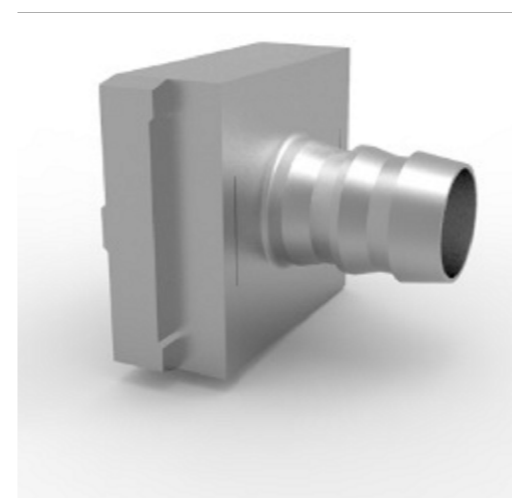

CRIMP FLANGE

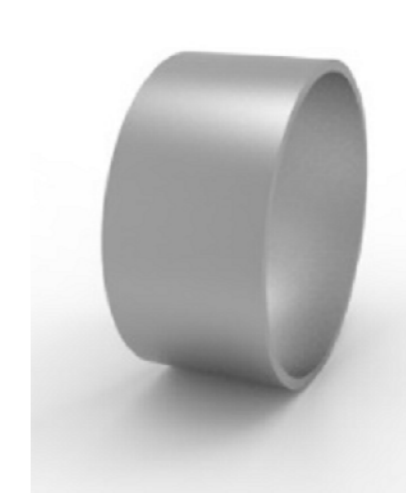

CRIMP BARREL

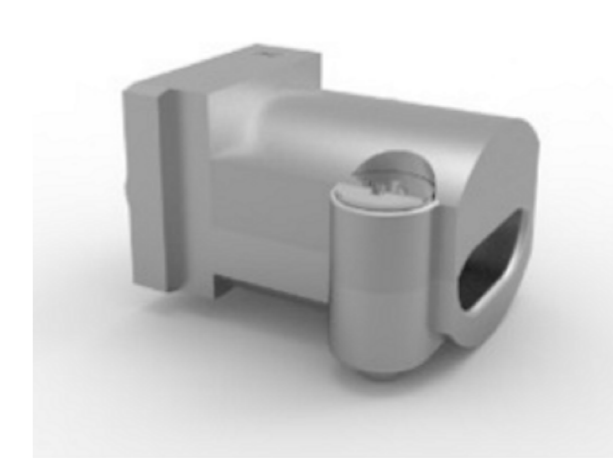

CABLE CLAMP

THIS DRAWING IS A CONTROLLED DOCUMENT.		DWN KIRAN K 02AUG2016		
DIMENSIONS: mm		CHK GUNASEKHAR G 02AUG2016		
TOLERANCES UNLESS OTHERWISE SPECIFIED: DIN ISO 2768-m DIN 16901 130B		APVD GUNASEKHAR G 02AUG2016	NAME FULL METAL HOODS SIZE 2	
		PRODUCT SPEC	SIZE A2	
MATERIAL		APPLICATION SPEC	CAGE CODE 00779	DRAWING NO G=2308341
FINISH		WEIGHT	RESTRICTED TO	
		CUSTOMER DRAWING	SCALE NTS	SHEET 2 of 2
			REV A1	

单击下面可查看定价，库存，交付和生命周期等信息

[>>TE Connectivity\(泰科\)](#)