

THIS DRAWING IS UNPUBLISHED. RELEASED FOR PUBLICATION NOV ,2003.
 © COPYRIGHT 2003 BY TYCO ELECTRONICS CORPORATION. ALL RIGHTS RESERVED.

LOC	DIST	REVISIONS			
P	LTR	DESCRIPTION	DATE	DWN	APVD
E	B	B	EBD0-0248-03	12NOV03	JMS FWK

- 1 SINGLE PACK IN ACCORDANCE WITH SPEC 107-3275
- 2 100 TRAY PACK IN ACCORDANCE WITH SPEC 107-3275
- 3 0.76µm Au PLATING OVER 1.27µm Ni PLATING OVER 0.76µm Cu PLATING
- 4 0.08µm Au PLATING OVER 1.27µm Ni PLATING OVER 0.76µm Cu PLATING
- 5 HANDTOOL 9-1478240-0
- 6 DIE SET 9-1478248-0

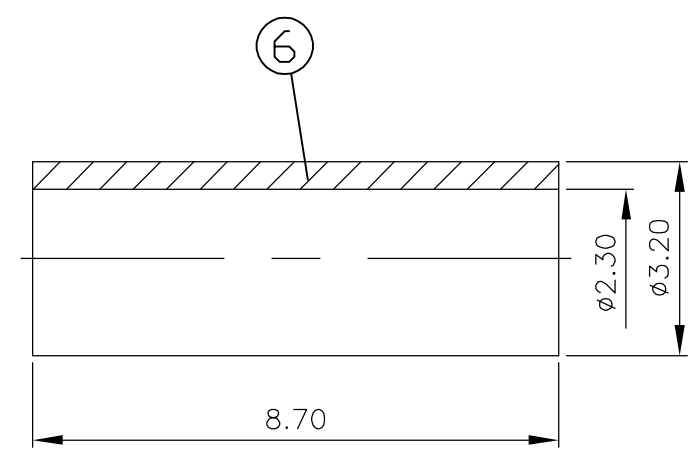
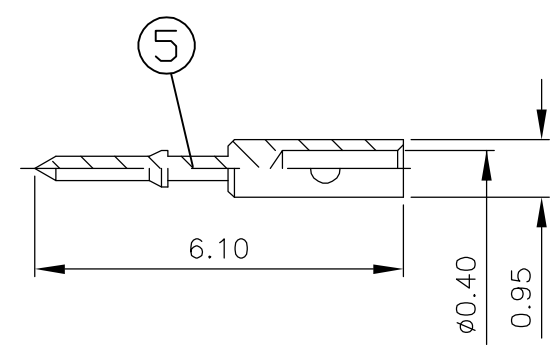
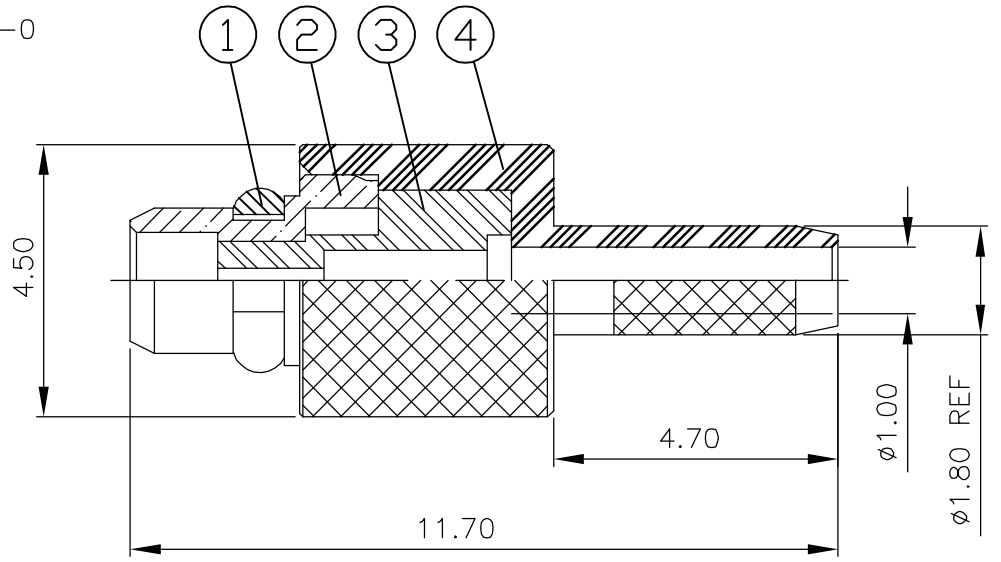

RECOMMENDED CENTRE CONTACT
A/F SQR

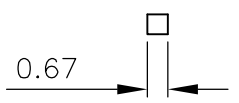

RECOMMENDED CRIMP SLEEVE
A/F HEX

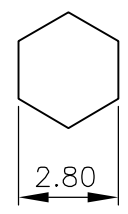

RECOMMENDED CABLE STRIPPING DIM'S

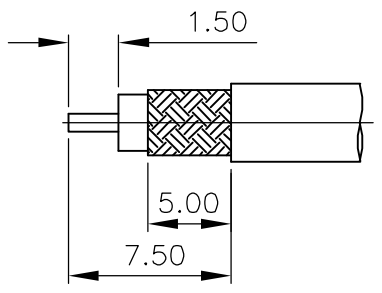

QTY	QTY	MATERIAL	DESCRIPTION	ITEM
1	1	BRASS	CRIMP SLEEVE	6
1	1	BRASS	PIN	5
1	1	BRASS	BODY	4
1	1	PTFE	INSULATOR	3
1	1	BRASS	BODY	2
1	1	BERYLLIUM COPPER	RETAINING RING	1
6--0	1--0	MATERIAL	DESCRIPTION	ITEM
2	1			

THIS DRAWING IS A CONTROLLED DOCUMENT.		DWN J.SANDWELL 12NOV03	Tyco Electronics Corporation Stanmore, Middlesex, HA7 4RS	
DIMENSIONS: MM		CHK S.PARLOW 12NOV03		
TOLERANCES UNLESS OTHERWISE SPECIFIED:		APVD F.WHEELER-KING 12NOV03	NAME MMCX STRAIGHT PLUG CRIMP RG178 50 OHMS	
0 PLC ± - 1 PLC ± - 2 PLC ± - 3 PLC ± - 4 PLC ± - ANGLES ± -		PRODUCT SPEC 108-3462	RESTRICTED TO	
MATERIAL SEE TABLE		FINISH SEE TABLE	APPLICATION SPEC 411-3278	SIZE A3
		WEIGHT -	CAGE CODE 00779	DRAWING NO C-1634001
CUSTOMER DRAWING			SCALE NTS	SHEET 1 OF 1
			REV B	

单击下面可查看定价，库存，交付和生命周期等信息

[>>TE Connectivity\(泰科\)](#)