

REVISIONS					
P	LTR	DESCRIPTION	DATE	DWN	APVD
C5	ECR-09-023726		29OCT2009	PKS	RRP
C6	ECR-14-009703		03JUL2014	SS	RR

PANEL CUT DIMENSIONS

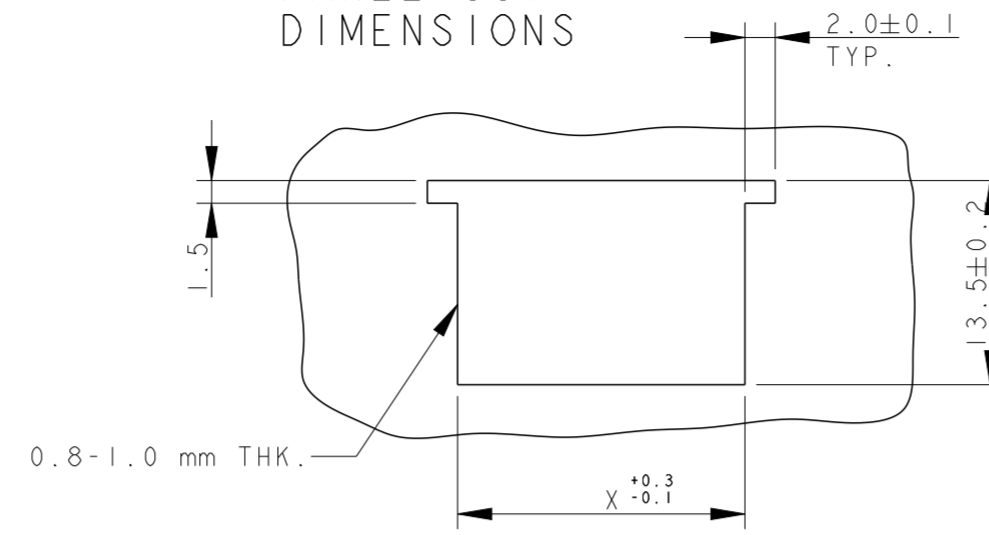

2 POS. HOUSING
P/N 928230-2
POLARIZATION KEYS SCHEME

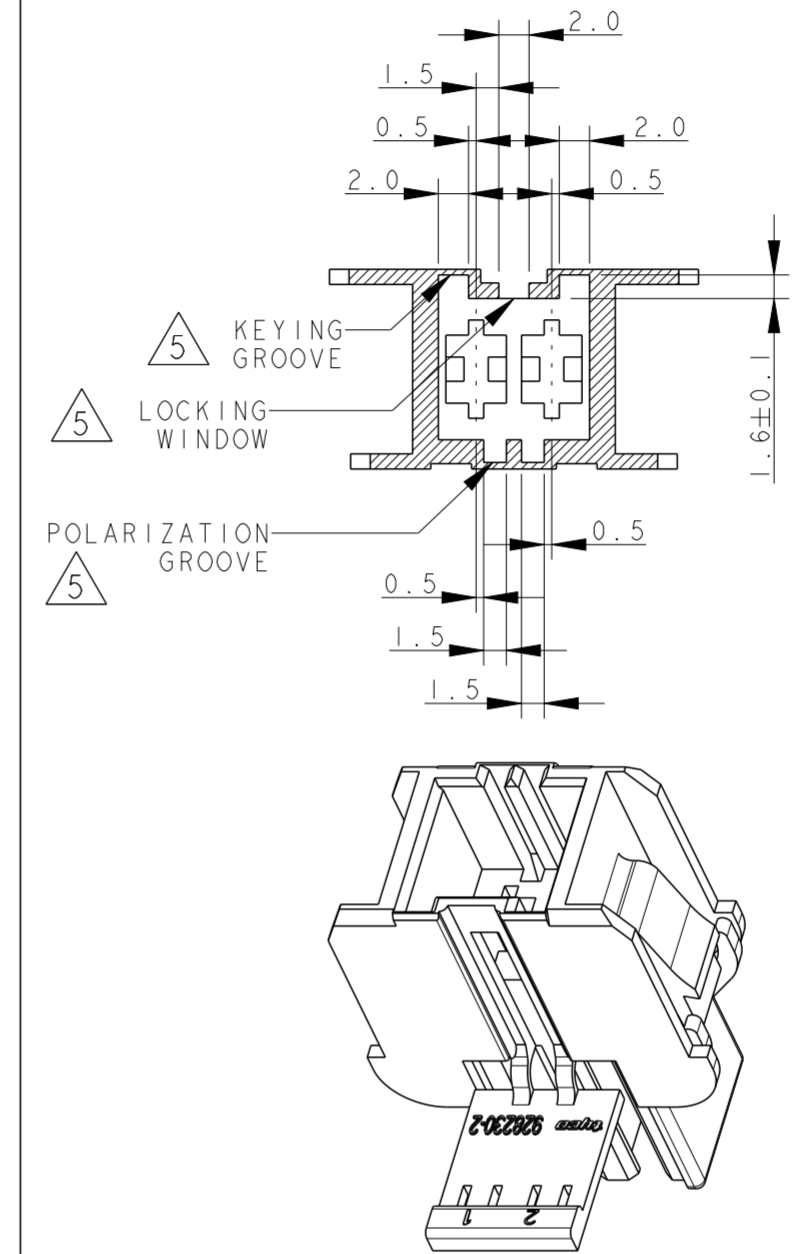

3 POS. HOUSING
P/N 928230-3
POLARIZATION KEYS SCHEME

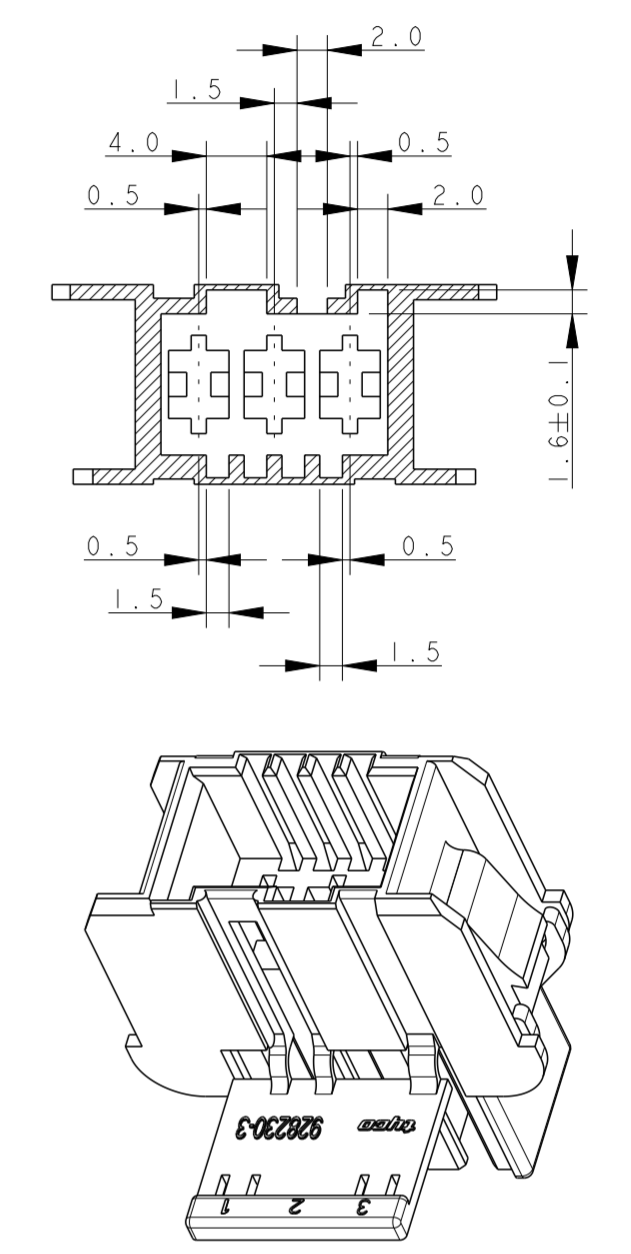

3 POS. HOUSING
P/N 1-928230-2
POLARIZATION KEYS SCHEME

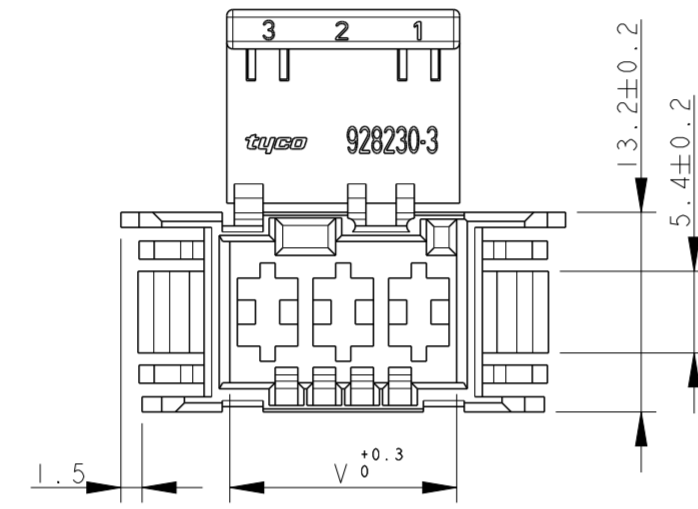
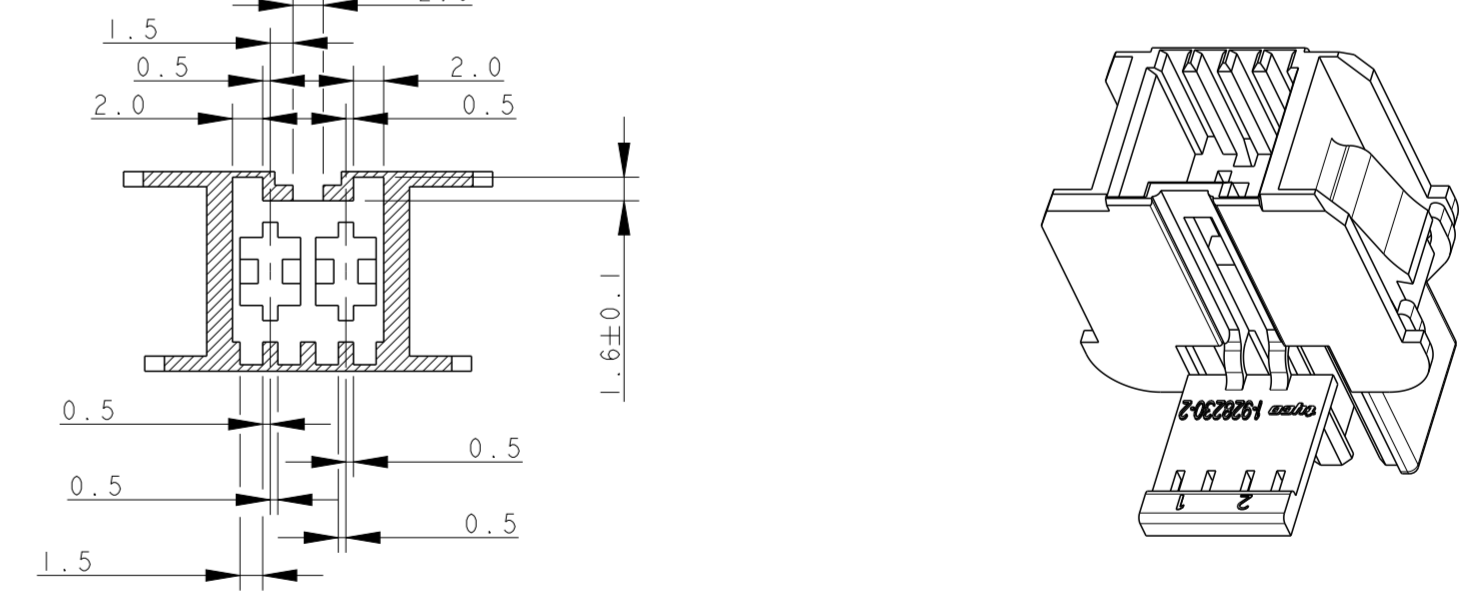

SECTION C-C

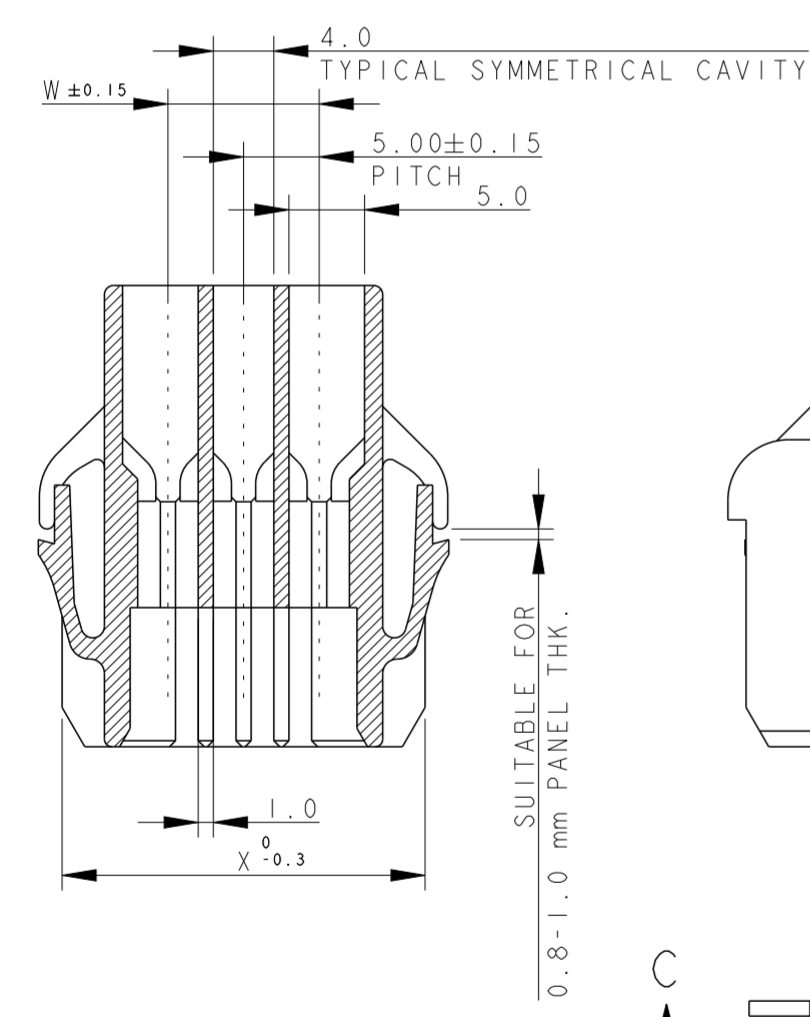

SECTION B-B

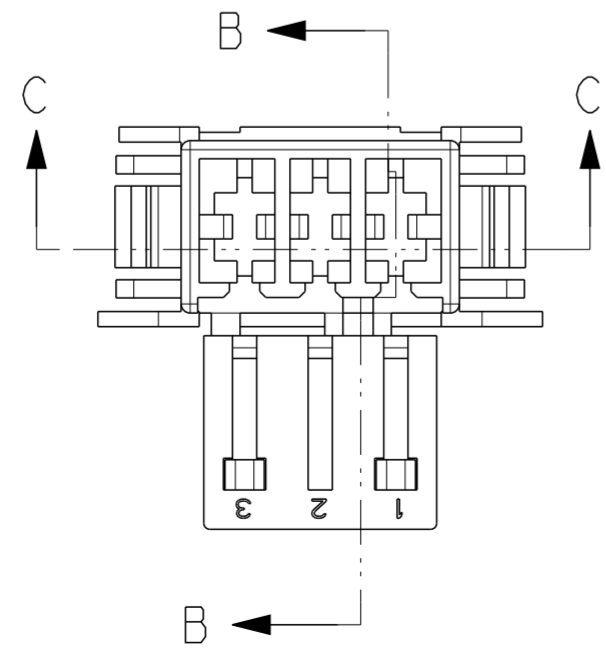
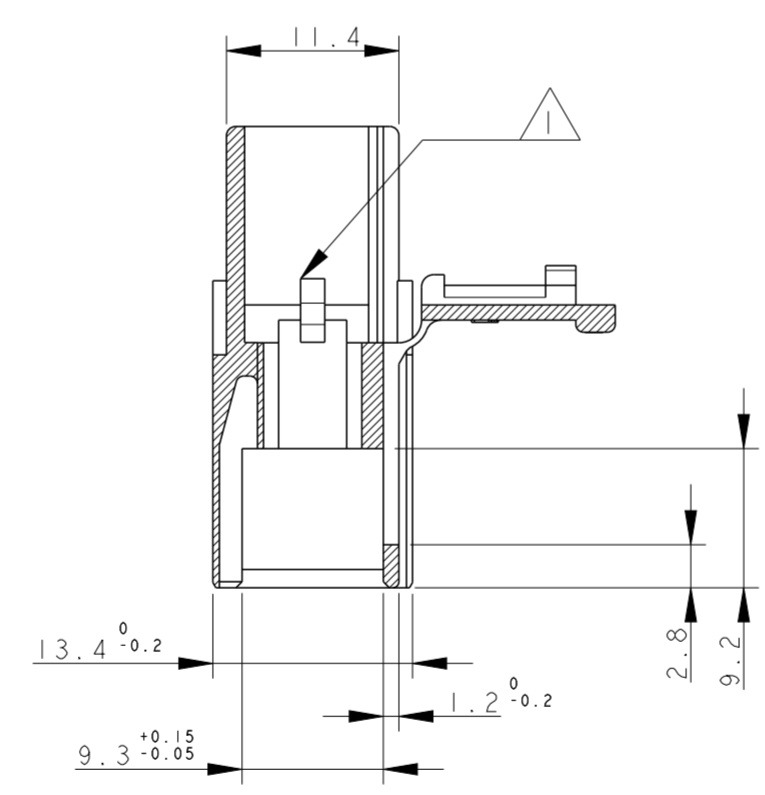

- 1 TYPICAL CAVITY SUITABLE FOR FASTIN-FASTON TAB CONTACT 6.3 mm SRS. P/N 293041.
- 2 PA66 UNFILLED, UL 94-V2, NATURAL COLOUR.
- 3 TE TRADEMARK "LOGO" AND TYCO ELECTRONICS "PART NUMBER" OPTIONAL POSITION.
- 4 CIRCUIT IDENTIFICATION NUMBERS.
- 5 POLARIZATION KEYS DIMENSIONS AND POSITIONS ARE ACCORDING TO "RAST 5" NORM
- 6 PRELIMINARY PART.

V	W	X	NOTE	COLOR	MATERIAL	TE P/N	REV
15.0	10.0	24.0		NATURAL	SEE NOTE 2	928230-3	C
10.0	5.0	19.0		NATURAL	SEE NOTE 2	1-928230-2	I
10.0	5.0	19.0		NATURAL	SEE NOTE 2	928230-2	C

THIS DRAWING IS A CONTROLLED DOCUMENT.

DWN	H. YAALI	31AUG2006
CHK	H. YAALI	31AUG2006
APVD	G. TURCO	
PRODUCT SPEC	108-20256	
APPLICATION SPEC		
WEIGHT		
CUSTOMER DRAWING		

NAME: 2-3 POS. FASTIN-FASTON* Connector, TAB HOUSING, RAST 5, PANEL MOUNT.

SIZE: A2 CAGE CODE: 0779 DRAWING NO: 928230 RESTRICTED TO: -

SCALE: 2:1 SHEET: 1 OF 1 REV: C6

单击下面可查看定价，库存，交付和生命周期等信息

[>>TE Connectivity\(泰科\)](#)