

REVISIONS				
P	LTR	DESCRIPTION	DATE	APVD
	J3	REVISED PER ECO-19-009164	23JUN2020	KG DR

AMP WIRE RANGE	E13288 Listed
1/0 AWG SOLID OR STRANDED	1/0 AWG STRANDED
LR7189 Certified	MILITARY P/N AND CLASS
1/0 AWG SOLID OR STRANDED	MS20659-117 CLASS 2

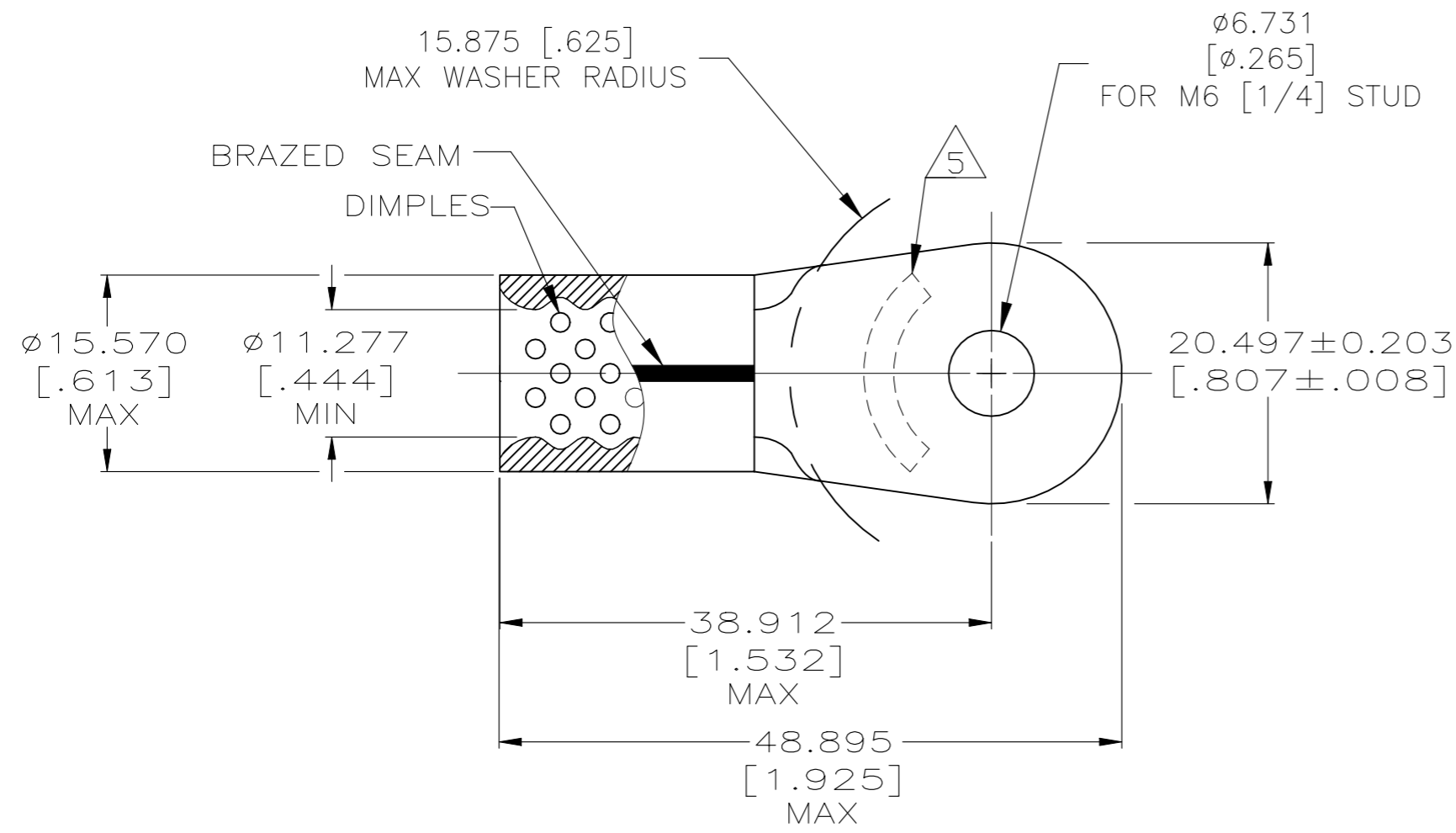

- TIN PLATE 0.00254[.000100] MIN EXT THK PER ASTM B545
- NOTE DELETED
- MATERIAL THICKNESS 1.778±0.076 [.070±.003]
- NICKEL PLATE 0.00762[.000300] MIN EXT THK PER SAE AMS QQ-N-290
- STAMP 1/0 W* APPROX AS SHOWN
- MATERIAL: COPPER PER ASTM B152, ANNEALED
- NOT UL, CSA OR MILITARY APPROVED. FOR STRANDED WIRE ONLY
- PRODUCT SPECIFICATION UL 486A-B, SAE AS7928

PRODUCT SPECIFICATION 108-32046
APPLICATION SPECIFICATION 114-2162

	343°C [649°F]	50	LOOSE PIECE	321866-1
	170°C [338°F]	50	LOOSE PIECE	321866
	MAX RECOMMENDED TEMP	QTY	PACKAGE TYPE	PART NO.

MAX RECOMMENDED OPERATING TEMPERATURE: SEE TABLE	THIS DRAWING IS A CONTROLLED DOCUMENT.		DWN DK SCHRUM 8/30/91	TE Connectivity				
	VOLTAGE RATING: N/A	DIMENSIONS: mm[INCHES]	CHK RD HEIM 9/30/91				APVD AJ KAUFMAN 9/30/91	NAME TERMINAL, RING TONGUE, SOLISTRAND AND STRATO-THERM HR, WIRE SIZE 1/0 AWG
CIRCULAR MIL AREA: 42.4-60.6mm² [83,700-118,500]	TOLERANCES UNLESS OTHERWISE SPECIFIED: 0 PLC ± - 1 PLC ± - 2 PLC ± - 3 PLC ± 0.127[.005] 4 PLC ± - ANGLES ± -	FINISH 	PRODUCT SPEC 	APPLICATION SPEC 	SIZE A3	CAGE CODE 00779	DRAWING NO C-321866	RESTRICTED TO -
	MATERIAL 		WEIGHT -	CUSTOMER DRAWING	SCALE 2:1	SHEET 1 OF 1	REV J3	

单击下面可查看定价，库存，交付和生命周期等信息

[>>TE Connectivity\(泰科\)](#)