

PART NUMBER	REV	DESCRIPTION	FIRST USED
2510896-1	A	SRC APPLICATOR UNIT, MID FORCE - LP	2348822-1] REVISIONS D AND HIGHER ONLY

REVISIONS					
P	LTN	DESCRIPTION	DATE	OWN	APVD
1		DEVELOPMENT	23FEB2023	LS	MP
2		REVISED	14SEP2023	JL	YY
3		REVISED	02JAN2024	JL	YY
A		RELEASED	31JAN2024	JL	YY

1. DETAILED INFORMATION TO FIND ON ASSEMBLY DRAWINGS.
2. TORQUE RECOMMENDATIONS PER 101-35000 UNLESS OTHERWISE SPECIFIED.
3. RECOMMENDED TERMINATOR:  
HV-20 TERMINATOR  
TCPN 2348822-1 OR 2348822-2  
\*ONLY TO USE WITH BASE PLATE ASSEMBLY,  
TCPN 2384466-4.

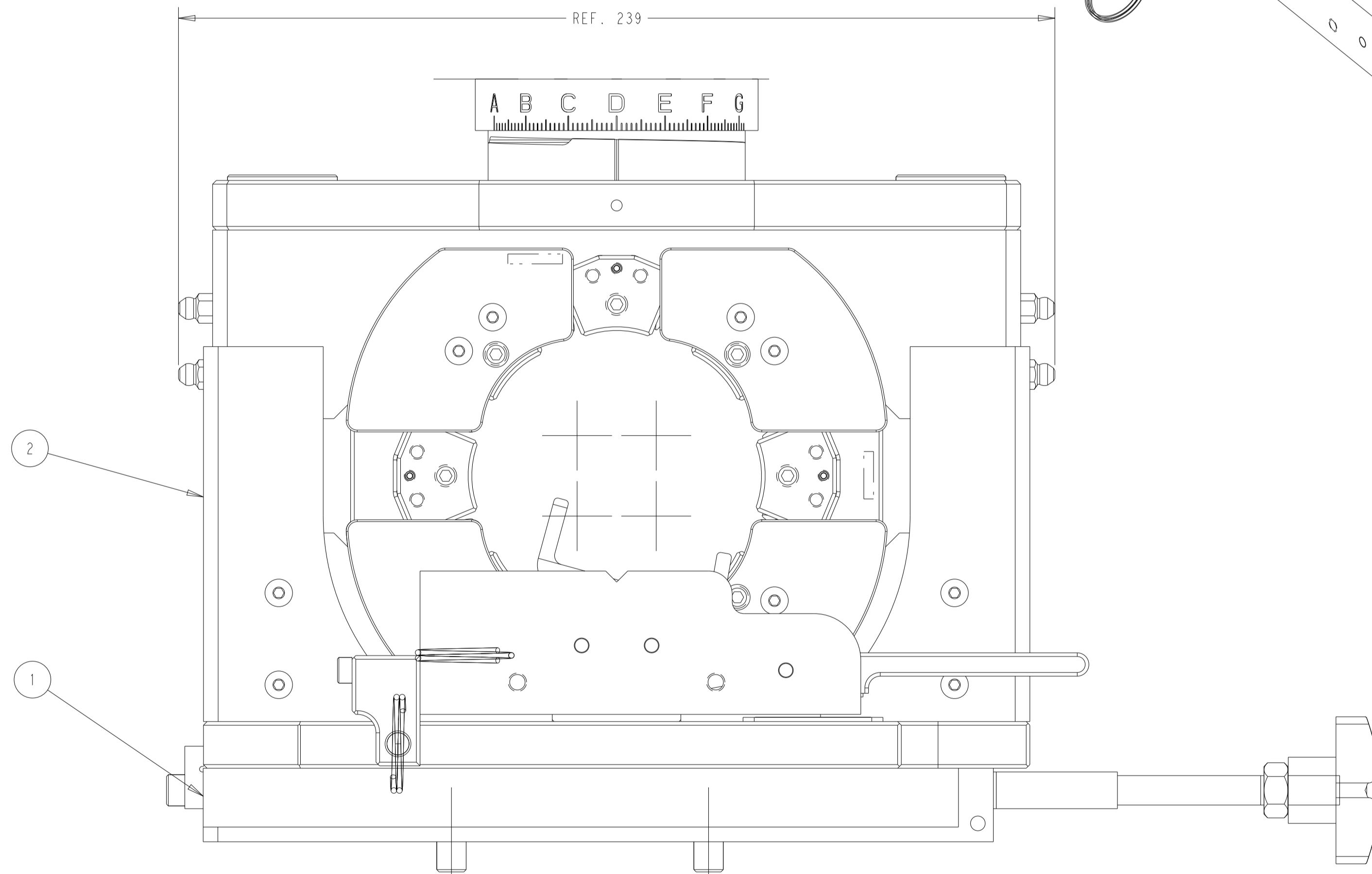
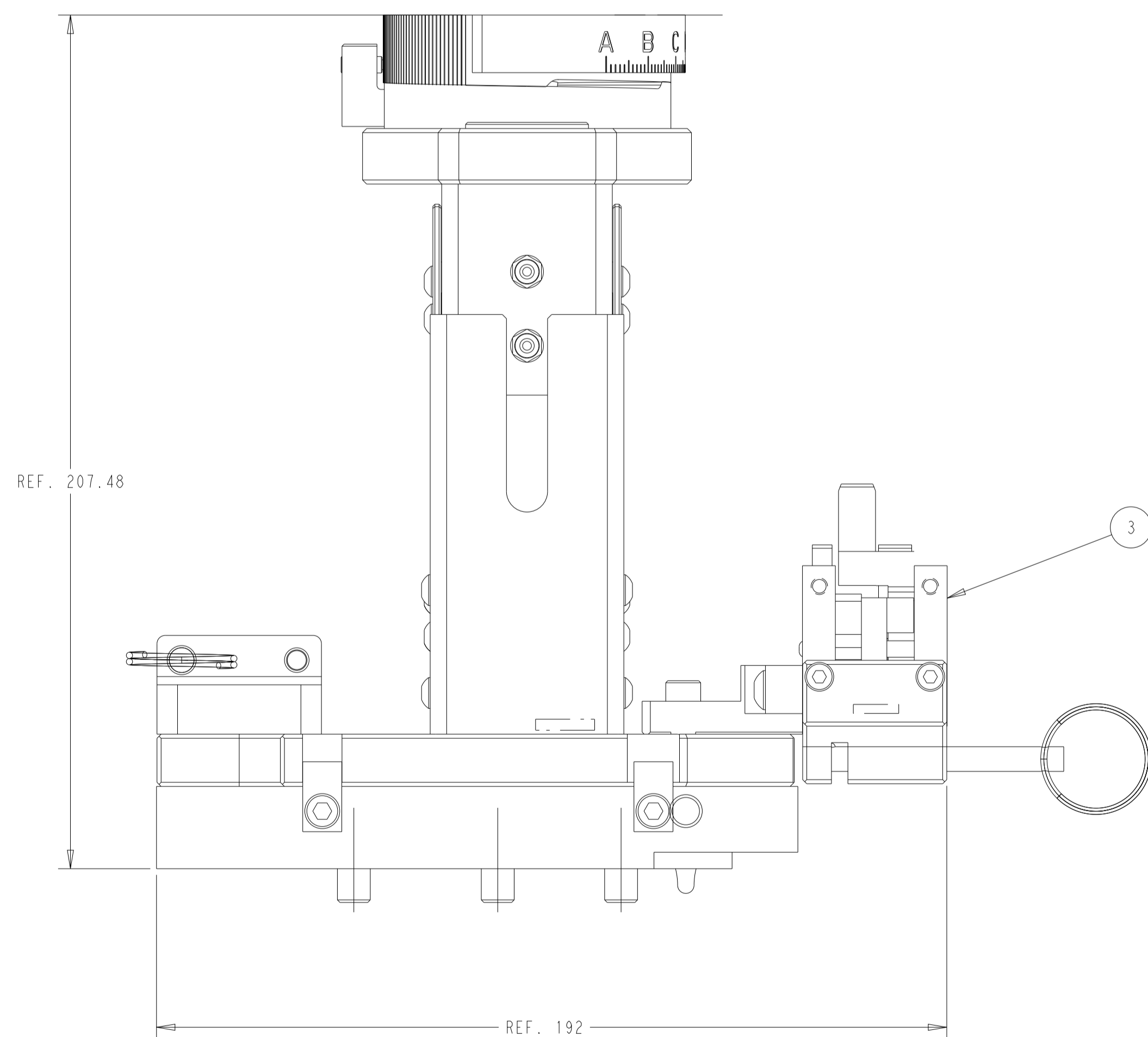
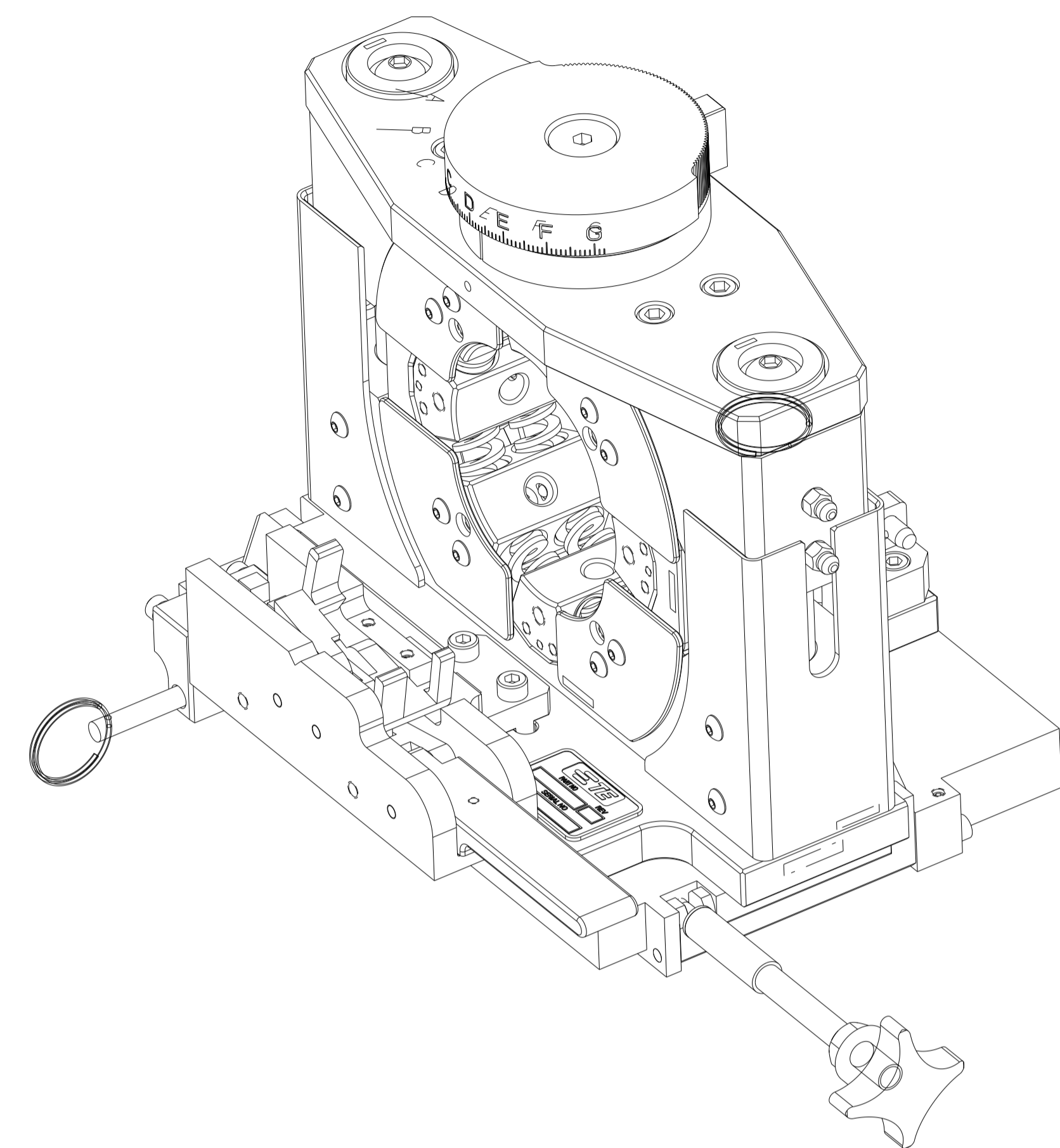

1	-	2364330-5	CABLE CLAMP	3
1	-	2440896-1	SRC APPLICATOR, MID FORCE - LP	2
1	-	2384466-4	BASE PLATE ASSEMBLY	1
- 1	U/M	PART NO	DESCRIPTION	ITEM NO

THIS DRAWING IS A CONTROLLED DOCUMENT.

DIMENSIONS: mm 	TOLERANCES UNLESS OTHERWISE SPECIFIED: 0 PLC ± 1 PLC ± 2 PLC ± 3 PLC ± 4 PLC ± ANGLES ± FINISH	OWN: L. SANDHU 23FEB2023 CHK: L. SANDHU 23FEB2023 APVD: M. PAJUELO 23FEB2023 PRODUCT SPEC APPLICATION SPEC SIZE: A   00779   C=2510896 WEIGHT: - CUSTOMER ACCESSIBLE PRODUCTION DRAWING	NAME: SRC APPLICATOR UNIT, MID FORCE - LP DATE: 23FEB2023 SCALE: 1:1 SHEET 1 OF 1 REV A
-----------------------	---	--	---

TE Connectivity

单击下面可查看定价，库存，交付和生命周期等信息

[>>TE Connectivity\(泰科\)](#)