

THIS DRAWING IS UNPUBLISHED. RELEASED FOR PUBLICATION  
 © COPYRIGHT BY TYCO ELECTRONICS CORPORATION. ALL RIGHTS RESERVED.

LOC		DIST		REVISIONS			
GP	00	P	LTR	DESCRIPTION	DATE	DWN	APVD
		L		REVISED PER ECO-10-000073	15FEB2010	CJV	SB

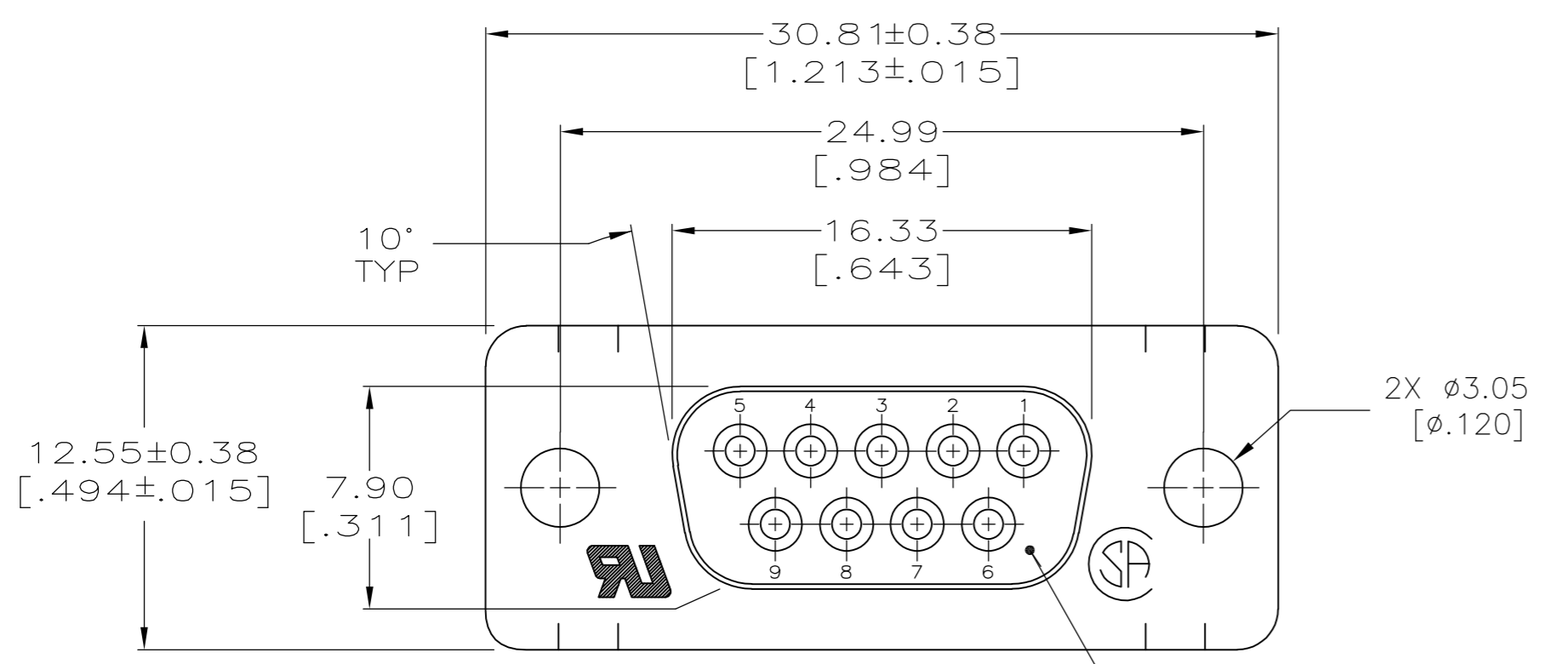

- ① MOLDED PARTS: FLAME RETARDANT 94V-0 RATED THERMOPLASTIC; BLACK.  
SHELLS: CARBON STEEL.  
CONTACTS: PHOS BRONZE.
- ② SHELLS: 5.08µm [.000200] MIN TIN OVER 2.54µm [.000100] MIN COPPER.
- ③ SHELLS: 5.08µm [.000200] MIN BRIGHT TIN OVER 2.54µm [.000100] MIN COPPER. (NO TIN-LEAD)
- ④ CONTACTS: GOLD FLASH ON MATING END, 2.54µm [.000100] MIN TIN-LEAD ON SOLDER END, BOTH OVER 1.27µm [.000050] MIN NICKEL.
- ⑤ CONTACTS: 0.76µm [.000030] MIN GOLD ON MATING END, 2.54µm [.000100] MIN TIN-LEAD ON SOLDER END, BOTH OVER 1.27µm [.000050] MIN NICKEL.  
-OR-  
GOLD FLASH OVER PALLADIUM-NICKEL, 0.76µm [.000030] MIN TOTAL ON MATING END, 2.54µm [.000100] MIN TIN-LEAD ON SOLDER END, BOTH OVER 1.27µm [.000050] NICKEL.

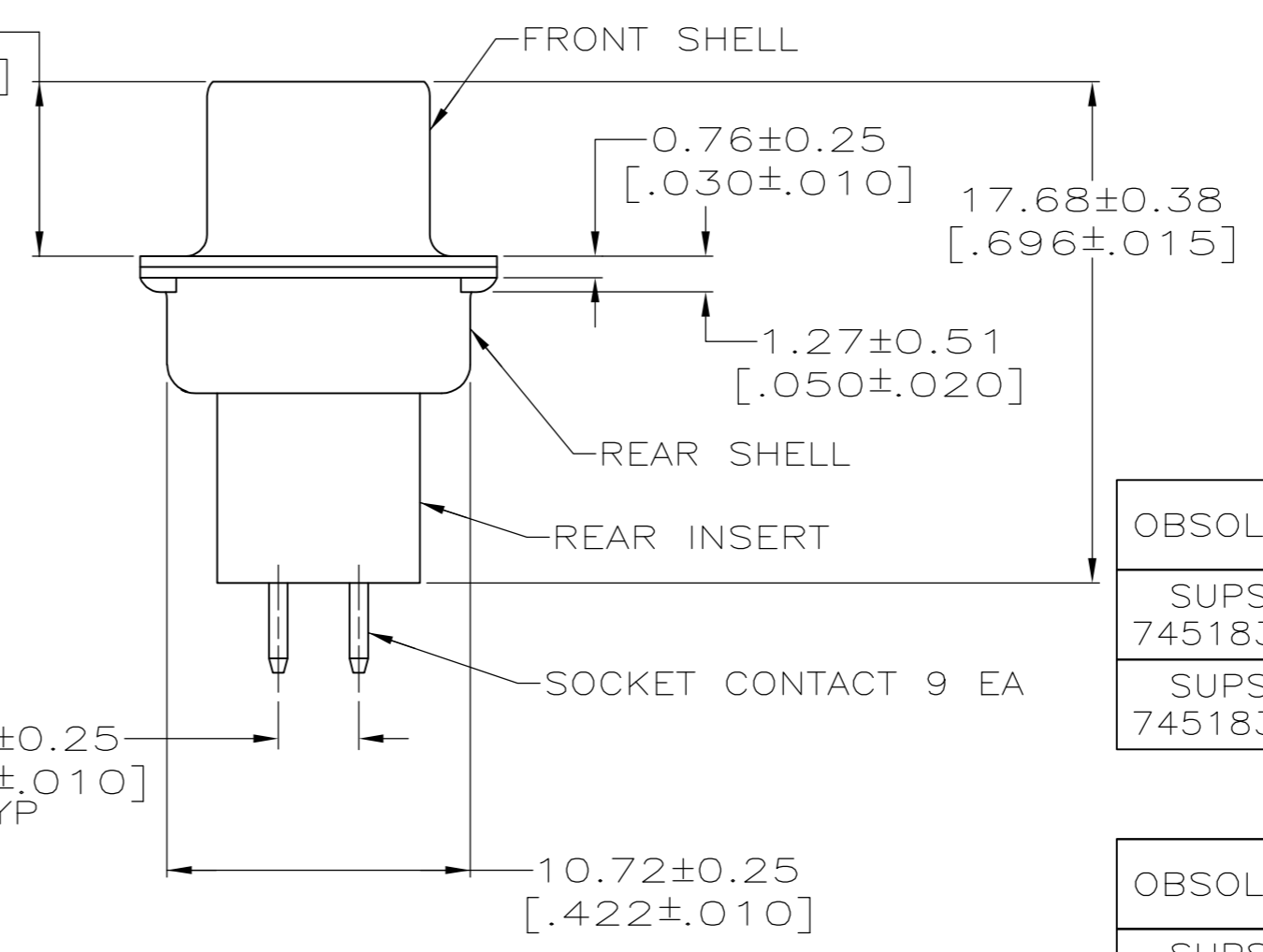
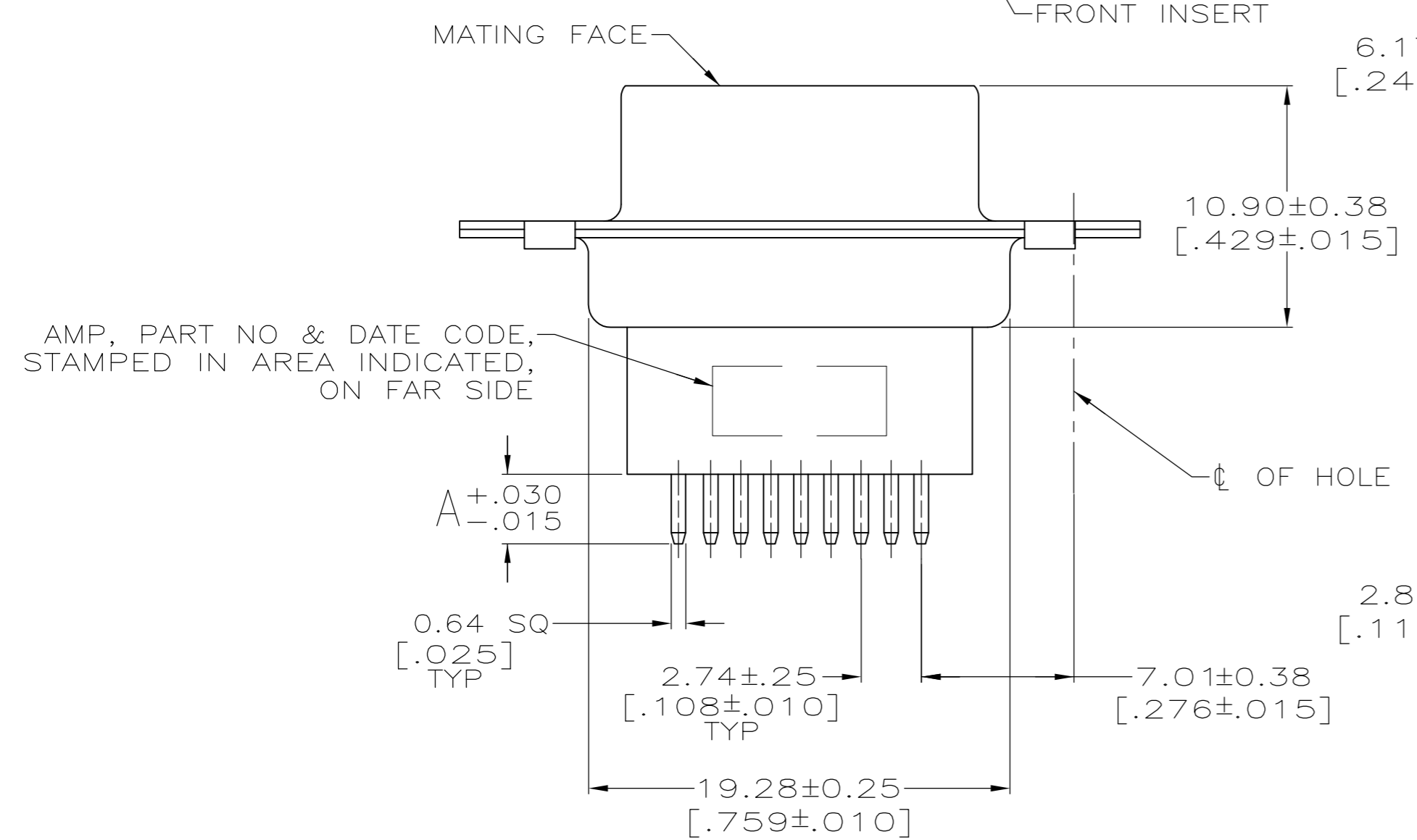

OBSOLETE	③⑤	4.78 [.188]	1-745183-0
SUPSD 745183-3	②④	8.43 [.322]	745183-9
SUPSD 745183-7	②④	4.78 [.188]	745183-8
	②⑤	4.78 [.188]	745183-7
OBSOLETE	-	-	745183-6
SUPSD 745183-3	②⑤	16.54 [.651]	745183-5
SUPSD 745183-3	②④	10.85 [.427]	745183-4
	②⑤	10.85 [.427]	745183-3
	②④	3.18 [.125]	745183-2
	②⑤	3.18 [.125]	745183-1
FINISH		DIM A	PART NUMBER

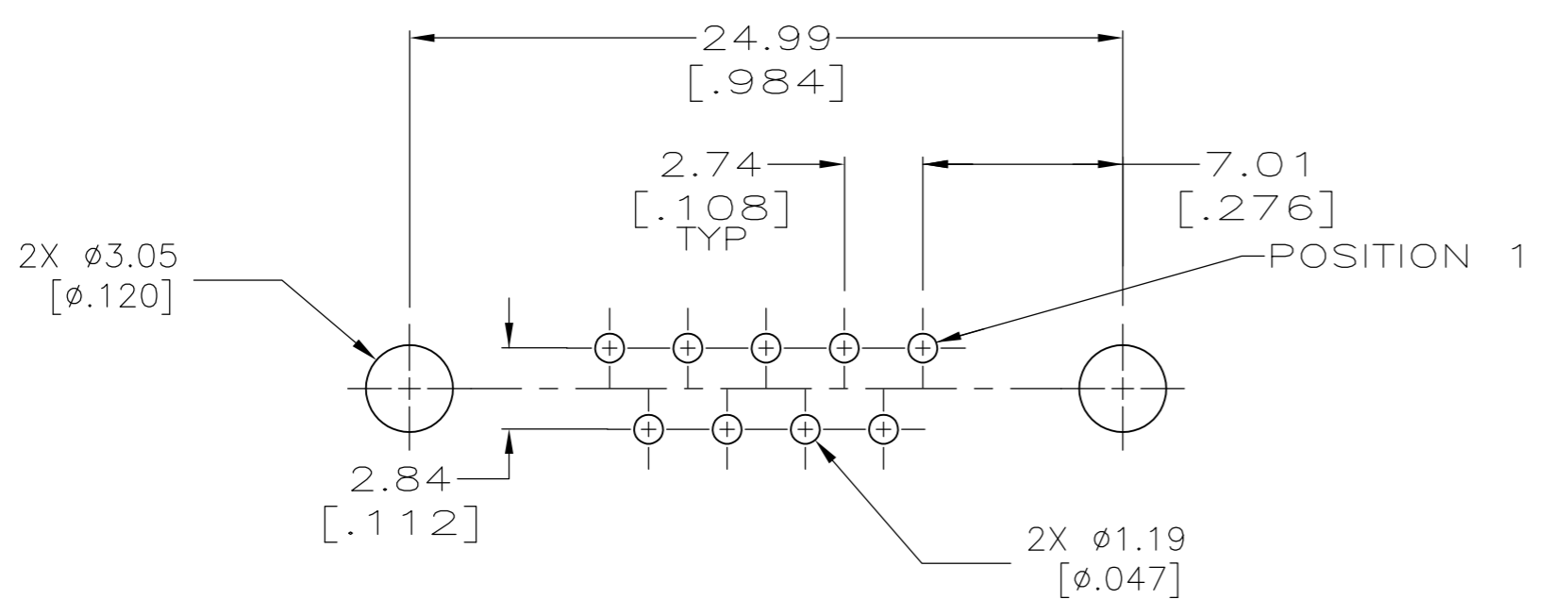

P.C. BOARD MOUNTING DIMENSIONS

THIS DRAWING IS A CONTROLLED DOCUMENT.		DWN C.REIFSNYDER 03 AUG 95	Tyco Electronics Corporation Harrisburg, PA 17105-3608	
DIMENSIONS: mm [INCHES]		CHK R.STONE 23 AUG 95	NAME RECEPTACLE ASSY, SIZE 1, 9 POS, VERTICAL, AMPLIMITE™HDP	
TOLERANCES UNLESS OTHERWISE SPECIFIED:		APVD R.TAYLOR 23 AUG 95	PRODUCT SPEC 108-40005	
0 PLC ± -		APPLICATION SPEC 114-40013	SIZE A2	
1 PLC ± -		WEIGHT -	CAGE CODE 00779	DRAWING NO C=745183
2 PLC ± 0.13 [.005]		FINISH SEE TABLE	SCALE NTS	SHEET 1 OF 1
3 PLC ± -		MATERIAL ①	CUSTOMER DRAWING	RESTRICTED TO -
4 PLC ± -				REV L
ANGLES ± 2°				

单击下面可查看定价，库存，交付和生命周期等信息

[>>TE Connectivity\(泰科\)](#)