

THIS DRAWING IS UNPUBLISHED. RELEASED FOR PUBLICATION
 © COPYRIGHT - By - ALL RIGHTS RESERVED.

REVISIONS					
P	LTR	DESCRIPTION	DATE	DWN	APVD
	H	REL -1 PER OG3A-0648-00	04OCT00	JR	MS
	H1	REVISED PER ECO-16-017419	13MAR2017	RS	DR

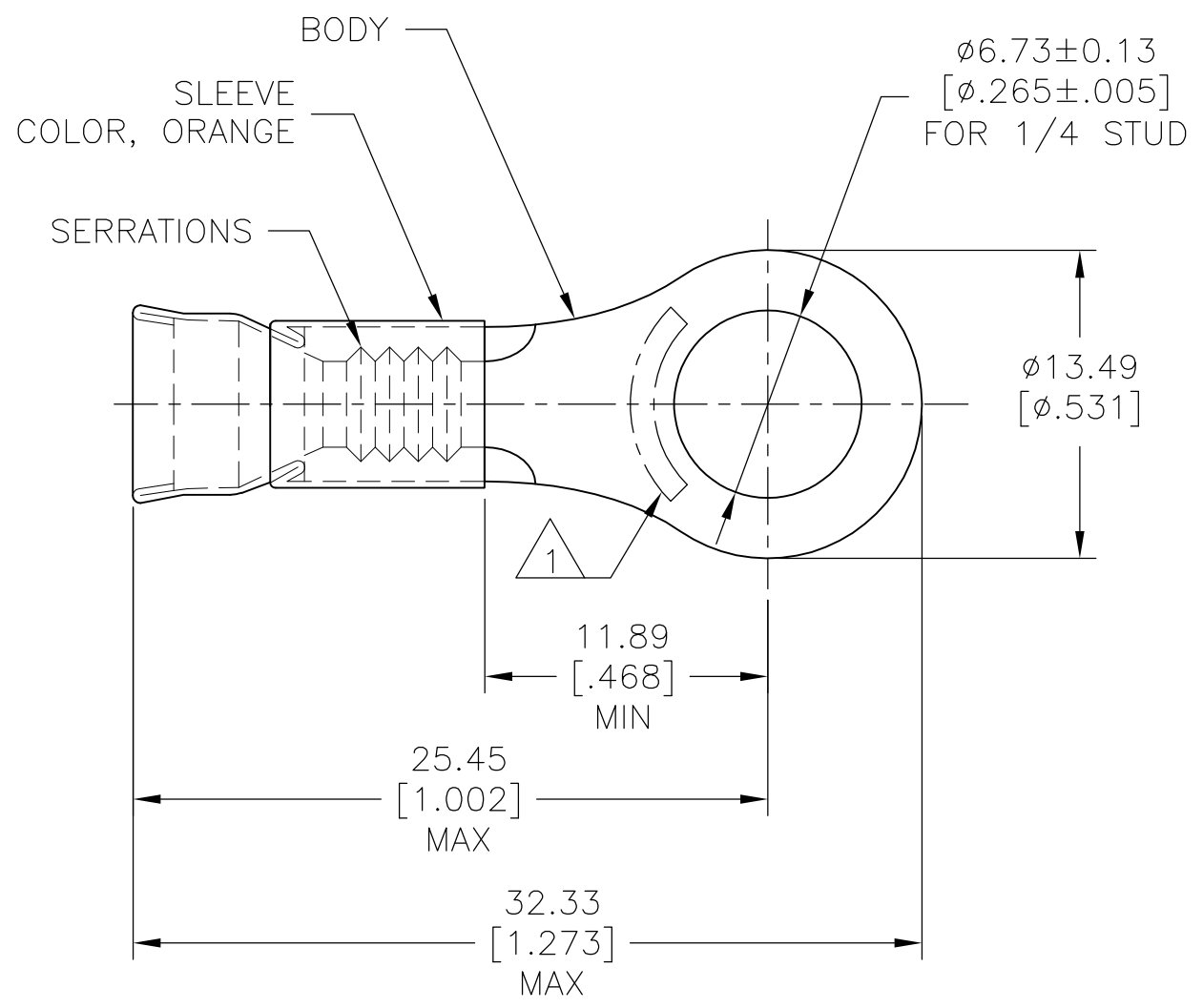

- △ 1 STAMP AMP 12-10 APPROX AS SHOWN.
- 2 WIRE INSUL DIA, Ø3.81-5.84 [Ø.150-.230].
- 3 TONGUE MATL THK, 1.02±0.05[.040±.002].
- △ 4 NO ORANGE COLOR CODE ON BARREL TO DENOTE NICKEL MATERIAL.
- △ 5 PRELIMINARY - NOT FOR PRODUCTION.

△ 4	2,500	ON TAPE, REEL	△ 5	323751-2
	500	LOOSE PIECE		323751
	QTY	PACKAGE TYPE		PART NO

AMP INCORPORATED CUSTOMER SERVICE SYSTEM		MAX RECOMMENDED OPERATING TEMPERATURE: 649°C [1200°F]		THIS DRAWING IS A CONTROLLED DOCUMENT.		DWN L OLMEDA 10OCT94		TE Connectivity			
FOR ADDITIONAL PRODUCT INFORMATION OR COPIES OF DRAWINGS AND TECHNICAL DOCUMENTS		PRODUCT INFORMATION CENTER 1-800-522-6752		DIMENSIONS: mm [INCHES]		TOLERANCES UNLESS OTHERWISE SPECIFIED:					
FOR APPLICATION TOOLING INFORMATION		TOOLING ASSISTANCE CENTER 1-800-722-1111		VOLTAGE RATING: -				APVD S BORTNER 10OCT94		PRODUCT SPEC	
FOR ORDER ENTRY		1-800-526-5142		CIRCULAR MIL AREA: 2.62mm ² -6.64mm ² [5180-13100] STRANDED WIRE		0 PLC ± - 1 PLC ± - 2 PLC ± 0.20 [.008] 3 PLC ± - 4 PLC ± - ANGLES ± - FINISH -		APPLICATION SPEC		TERMINAL, RING TONGUE, STRATO-THERM™, DIAMOND GRIP™, WIRE SIZE, 12-10 AWG	
						MATERIAL BODY, NI PER ASTM B162 SLEEVE, NI SIL PER ASTM B122		WEIGHT -		RESTRICTED TO	
						CUSTOMER DRAWING		SCALE 4:1		SHEET 1 OF 1	
								SIZE A3		CAGE CODE 00779	
								DRAWING NO C-323751		REV H1	

单击下面可查看定价，库存，交付和生命周期等信息

[>>TE Connectivity\(泰科\)](#)