

THIS DRAWING IS UNPUBLISHED. RELEASED FOR PUBLICATION 20
 © COPYRIGHT 20 BY TYCO ELECTRONICS CORPORATION. ALL RIGHTS RESERVED.

LOC	DIST	REVISIONS			
P	LTR	DESCRIPTION	DATE	DWN	APVD
GP	00	A	RELEASED	25AUG2008	RG DO

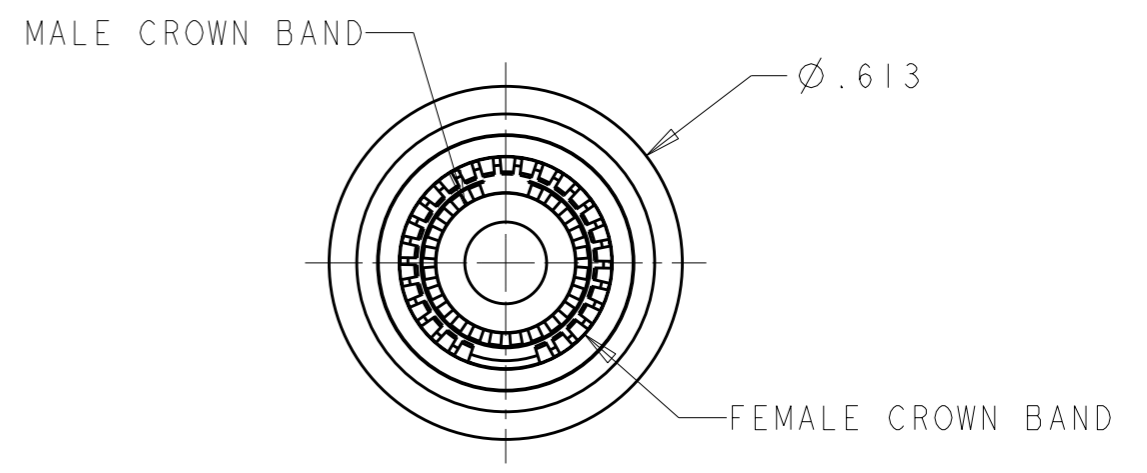
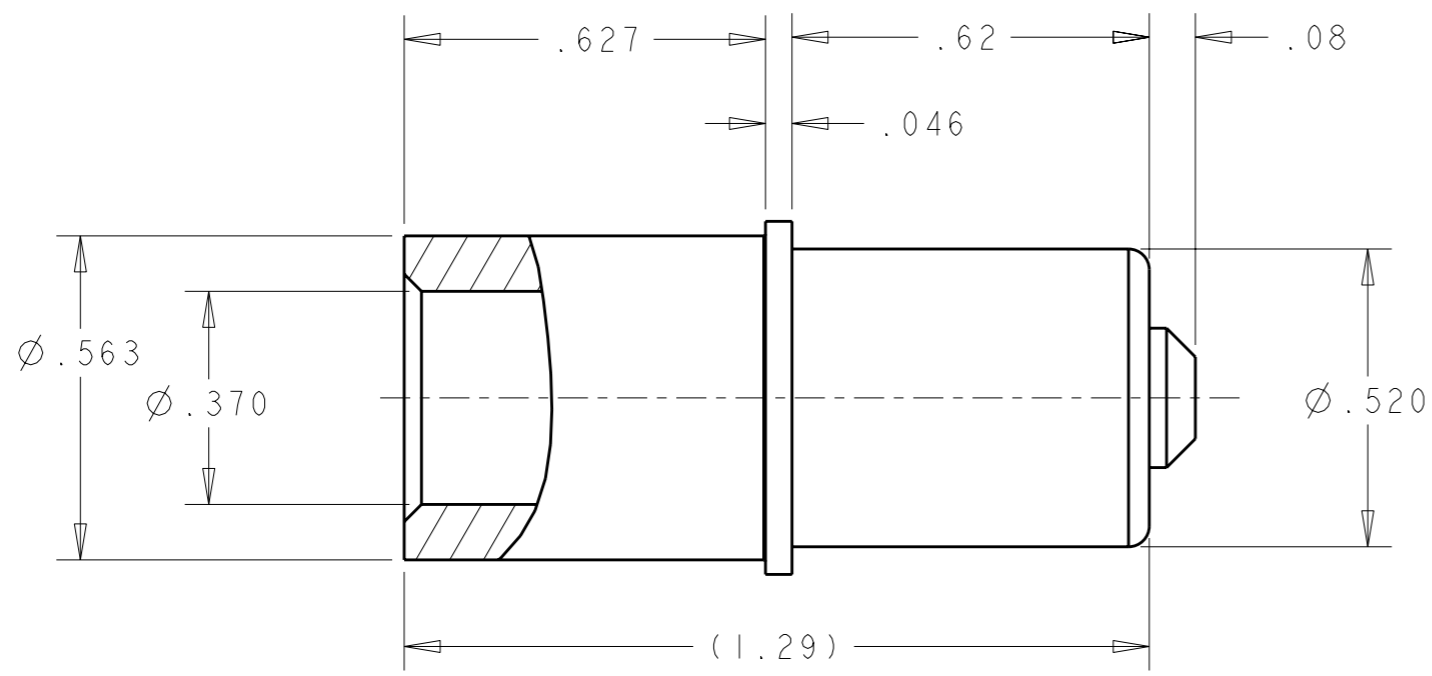

- PART NUMBER CHANGES AND/OR DESIGN CHANGES AFFECTING ITEM INTERCHANGEABILITY REQUIRES PRIOR TYCO ELECTRONICS APPROVAL AND AUTHORIZATION BY REVISION TO THIS DRAWING.
- ITEMS PROVIDED TO THIS SPECIFICATION SHALL BE IDENTIFIED ON THE CONTAINER WITH THE FOLLOWING INFORMATION:

TYCO ELECTRONICS P/N: XXXXXXXX-X
 DATE CODE (e.g. 0106): XXXX
 YEAR: 1 WEEK

3 MATERIAL:
 SOCKET BODY AND HOOD: COPPER ALLOY
 CROWN: COPPER ALLOY
 PROBE PROOF CAP: THERMOPLASTIC, UL 94V-0 RECONGIZED

4 FINISH:
 SOCKET BODY AND HOOD: SILVER PLATE .000200 MIN THK.
 OVER NICKEL PLATE .000050 MIN THK.
 CROWN BANDS: GOLD PLATE .000030 MIN THK.
 OVER NICKEL .000050 MIN THK.

AS SHOWN	1926899-1
DESCRIPTION	PART NO.

<small>THIS DRAWING IS A CONTROLLED DOCUMENT FOR TYCO ELECTRONICS CORPORATION IT IS SUBJECT TO CHANGE AND THE CONTROLLING ENGINEERING ORGANIZATION SHOULD BE CONTACTED FOR THE LATEST REVISION.</small>		DWN R.GRZYBOWSKI 18AUG2008 CHK D.ORRIS 18AUG2008 APVD M.PERCHERKE 18AUG2008		Tyco Electronics Tyco Electronics Harrisburg, PA 17105-3608	
DIMENSIONS: INCHES 		TOLERANCES UNLESS OTHERWISE SPECIFIED: 0 PLC ±- 1 PLC ±- 2 PLC ±.02 3 PLC ±.010 4 PLC ±- ANGLES ±5		NAME CONTACT, SOCKET, SIZE No.0 WITH CRIMP No.2 AWG CRIMP DOUBLE CROWN	
MATERIAL 3		FINISH 4		PRODUCT SPEC - APPLICATION SPEC - WEIGHT -	
CUSTOMER DRAWING		SCALE 3:1		SIZE A3 CAGE CODE 00779 DRAWING NO C-1926899 RESTRICTED TO -	
				SHEET 1 OF 1 REV A	

单击下面可查看定价，库存，交付和生命周期等信息

[>>TE Connectivity\(泰科\)](#)