

THIS DRAWING IS UNPUBLISHED. RELEASED FOR PUBLICATION, 19
 © COPYRIGHT 19 BY AMP INCORPORATED. ALL INTERNATIONAL RIGHTS RESERVED.

LOC	DIST	P	F	ZONE	LTR	DESCRIPTION	DATE	APPD
AF	50				A	RELEASE PER FASR & 0L10-0245-96	03/JAN/97	PF/DS

1 CONTINUOUS STRIP ON REEL.

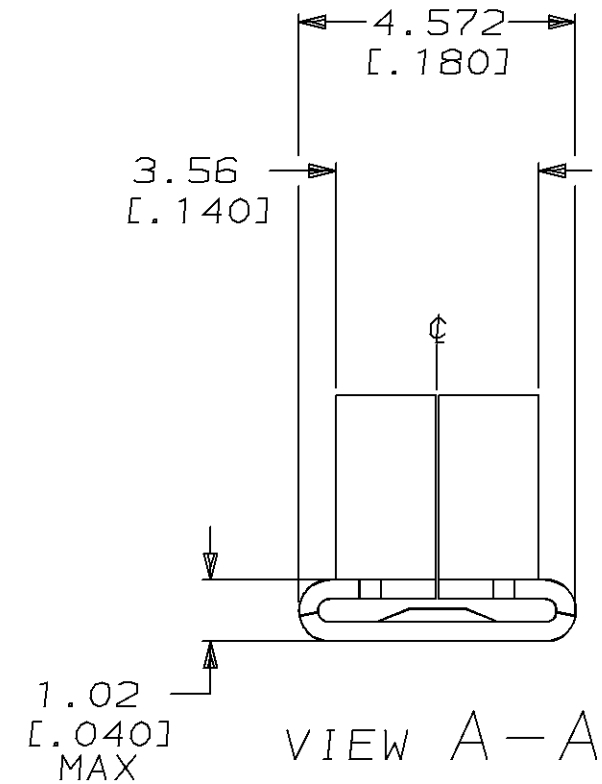
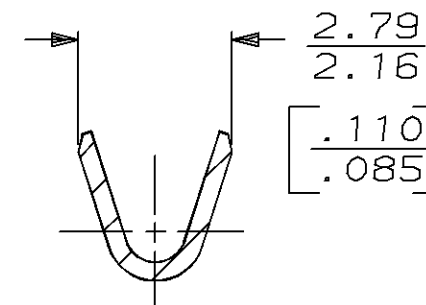
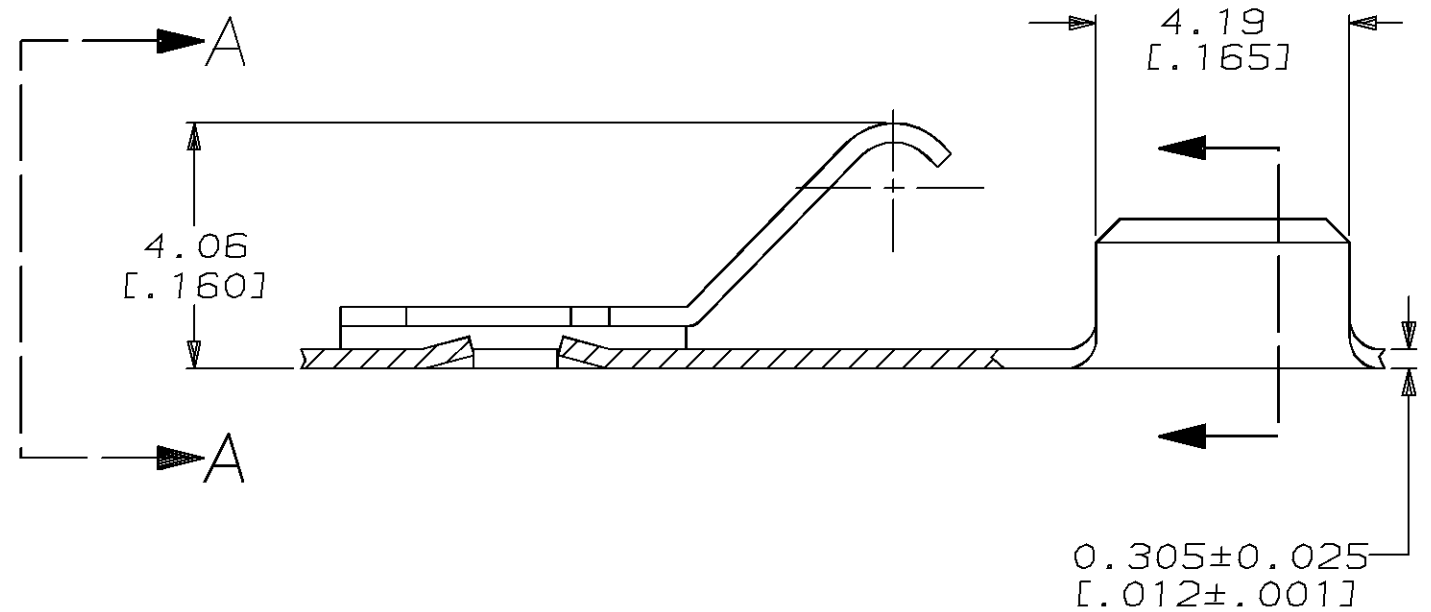
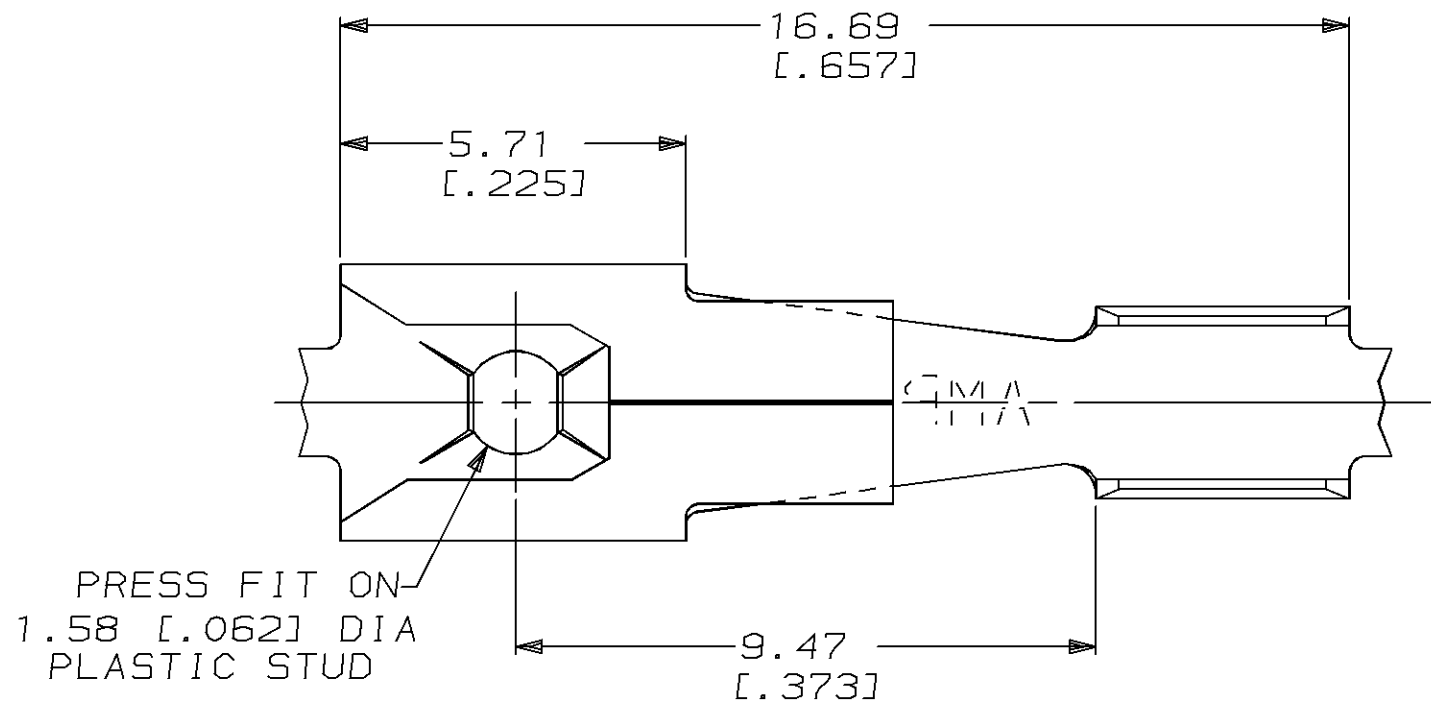

THIS DRAWING IS A CONTROLLED DOCUMENT FOR AMP INCORPORATED. IT IS SUBJECT TO CHANGE AND THE CONTROLLING ENGINEERING ORGANIZATION SHOULD BE CONTACTED FOR THE LATEST REVISION.

DO NOT SCALE PRINT. UNLESS SPECIFIED DIMENSIONS IN mm [INCHES] TOLERANCES ON: 2 PLC DEC ± 0.25 [.010] 3 PLC DEC ± - ANGLES ± -		DR 18/SEP/96 PHILLIP M FORTNEY	[22-18] AWG	63937-1
MATERIAL H04 PHOS BRONZE	CHK 18/SEP/96 JEFF R RUTH	APPD 18/SEP/96 DENNIS SCHWENK	WIRE RANGE	
FINISH	APPD 18/SEP/96 MARK BARNABA	PRODUCT SPEC	PART NO	
APPLICATION SPEC		WEIGHT -	AMP AMP Incorporated Harrisburg, PA 17105-3608	
NAME SPECIAL TERMINAL		SIZE B	CAGE CODE 00779	DRAWING NO C-63937
SCALE 8:1		SHEET 1 OF 1		

单击下面可查看定价，库存，交付和生命周期等信息

[>>TE Connectivity\(泰科\)](#)