

THIS DRAWING IS UNPUBLISHED. RELEASED FOR PUBLICATION
 © COPYRIGHT - By - ALL RIGHTS RESERVED.

LOC	DIST	REVISIONS					
		P	LTR	DESCRIPTION	DATE	DWN	APVD
-	-		A3	REVISED PER ECO-12-011771	26JUN12	KH	JO

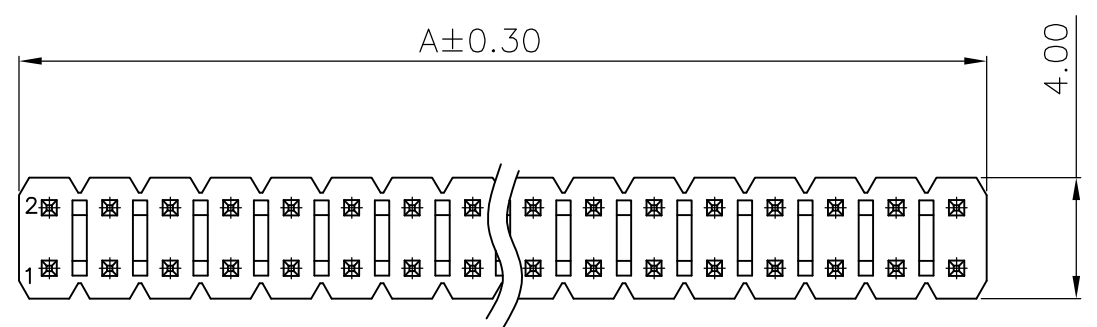

- 1 MATERIAL :
HOUSING : THERMOPLASTIC(PA6T), UL94V-0, BLACK COLOR
CONTACT : BRASS.
- 2 FINISH :
CONTACT: 0.2μm [8μ"] MIN. GOLD PLATED ON CONTACT AREA
2.54μm [100μ"] MIN. MATTE TIN PLATED ON SOLDER TAILS,
1.27μm [50μ"] MIN. NICKEL UNDERPLATED OVER ALL
- 3 FINISH :
CONTACT: 0.2μm [8μ"] MIN. GOLD PLATED OVER ALL
1.27μm [50μ"] MIN. NICKEL UNDERPLATED OVER ALL
- 4 WAVE SOLDER CAPABLE TO 265°C PER TE SPEC 109-202, CONDITION B.

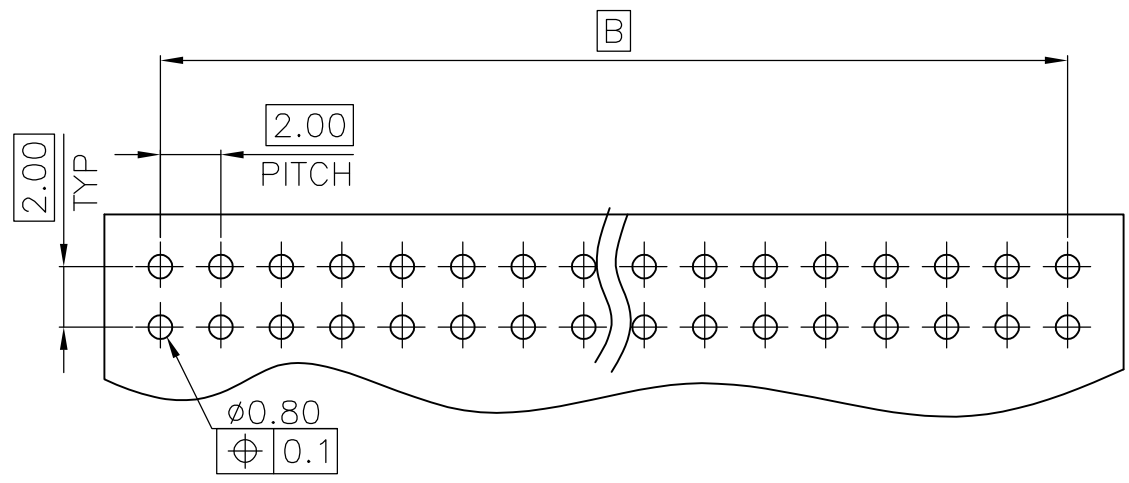
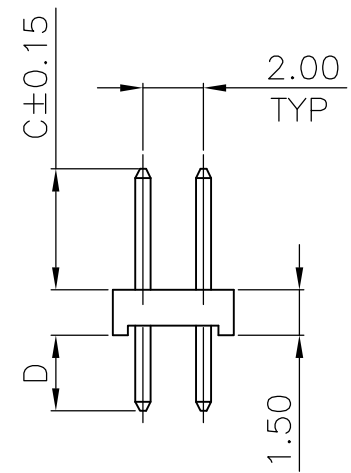
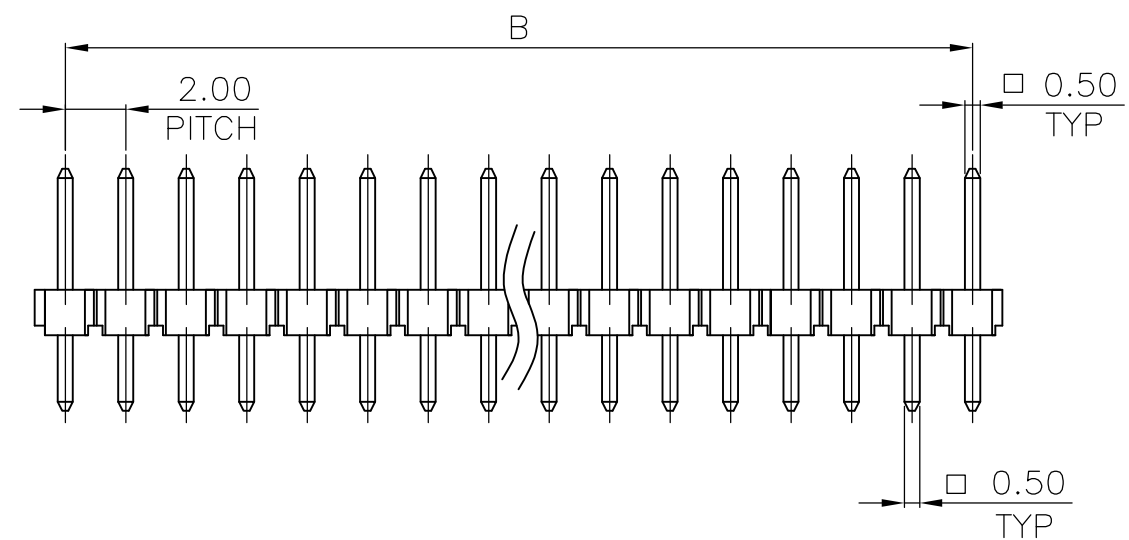

RECOMMENDED PCB LAYOUT
TOP VIEW, TOLERANCE: ±0.05

FINISH	WEIGHT(g)	D	C	B	A	POSITION NUMBER	PART NUMBER
3	0.18	0.8	4.00	8.00	10.00	10	2041051-2
2	0.3	2.50	7.80	8.00	10.00	10	2041051-1

THIS DRAWING IS A CONTROLLED DOCUMENT.		DWN S. CHIEN 24APR2008	STE TE Connectivity			
DIMENSIONS: mm		CHK S. CHIEN 24APR2008				
TOLERANCES UNLESS OTHERWISE SPECIFIED:		APVD W. KODAMA 24APR2008	NAME			
0 PLC ± -		PRODUCT SPEC	AMPMODU 2.00MM PITCH POST HDR VERTICAL MOUNT TYPE			
1 PLC ± 0.30		108-57197	-			
2 PLC ± 0.20		APPLICATION SPEC	SIZE	CAGE CODE	DRAWING NO	RESTRICTED TO
3 PLC ± -		501-57197	A3	00779	C-2041051	-
4 PLC ± -		WEIGHT See Table				
ANGLES ± 3'		CUSTOMER DRAWING	SCALE -	SHEET 1 OF 5	REV A3	
MATERIAL SEE NOTE	FINISH SEE NOTE					

THIS DRAWING IS UNPUBLISHED. RELEASED FOR PUBLICATION
 © COPYRIGHT - By - ALL RIGHTS RESERVED.

LOC	DIST	REVISIONS					
		P	LTR	DESCRIPTION	DATE	DWN	APVD
-	-	-	-	SEE SHEET 1	-	-	-

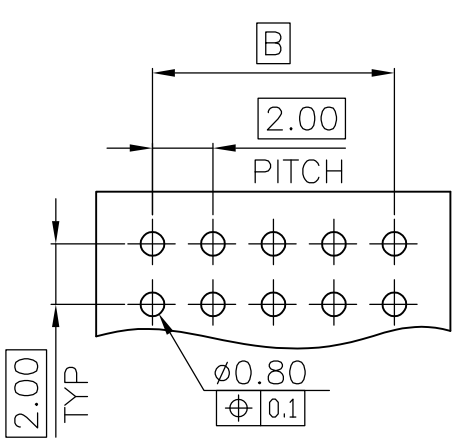
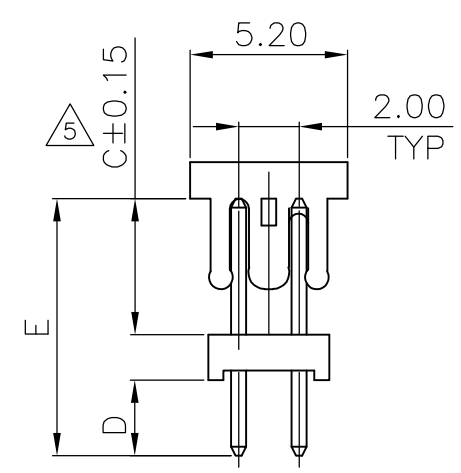
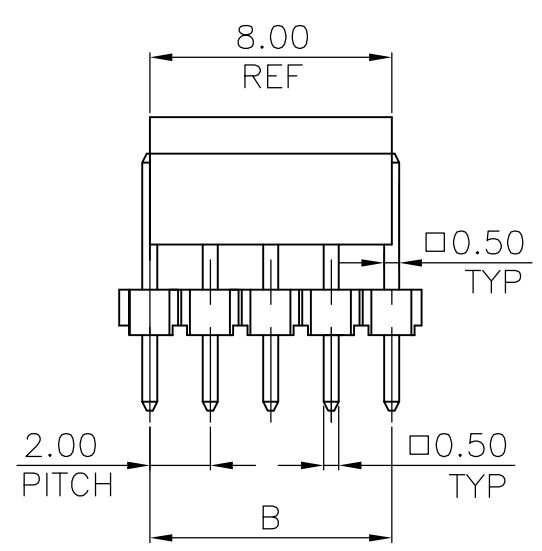
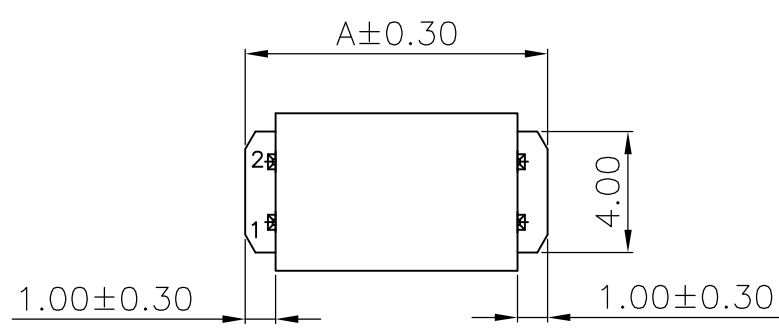

RECOMMENDED PCB LAYOUT
 TOP VIEW, TOLERANCE: ±0.05

- 1 MATERIAL :
 HOUSING : PA6T WITH 30% GF, UL 94V-0, BLACK COLOR
 CAP: LCP WITH 30% GF, UL 94V-0, BLACK COLOR.
 CONTACT : BRASS.
- 2 FINISH :
 CONTACT: 0.2µm [8µ"] MIN. GOLD PLATED ON CONTACT AREA
 2.54µm [100µ"] MIN. MATTE TIN PLATED ON SOLDER TAILS,
 1.27µm [50µ"] MIN. NICKEL UNDERPLATED OVER ALL
- 3 FINISH :
 CONTACT: 0.2µm [8µ"] MIN. GOLD PLATED OVER ALL
 1.27µm [50µ"] MIN. NICKEL UNDERPLATED OVER ALL
- 4 WAVE SOLDER CAPABLE TO 265°C PER TE SPEC 109-202, CONDITION B.
- 5 DIMENSION IS FROM TOP OF HOUSING TO BOTTOM LEDGE OF CAP

FINISH	WEIGHT(g)	DIMENSIONS					POSITION NUMBER	PART NUMBER
		E	D	C	B	A		
2	0.50	11.04	2.50	7.04	8.00	10.00	10	1-2041051-4
2	0.47	10.16	2.50	6.16	8.00	10.00	10	1-2041051-3
2	0.40	8.50	2.50	4.50	8.00	10.00	10	1-2041051-2
3	0.32	6.30	0.8	4.00	8.00	10.00	10	2041051-4
2	0.48	11.80	2.50	7.80	8.00	10.00	10	2041051-3

THIS DRAWING IS A CONTROLLED DOCUMENT.		DWN	TE Connectivity			
DIMENSIONS: mm		CHK				
TOLERANCES UNLESS OTHERWISE SPECIFIED:		APVD	NAME			
0 PLC ± -		PRODUCT SPEC	AMPMODU 2.00MM PITCH POST HDR VERTICAL MOUNT TYPE			
1 PLC ± 0.30		APPLICATION SPEC	-			
2 PLC ± 0.20		WEIGHT	SIZE	CAGE CODE	DRAWING NO	RESTRICTED TO
3 PLC ± -		See Table	A3	00779	C-2041051	-
4 PLC ± -		CUSTOMER DRAWING	SCALE	SHEET	REV	
ANGLES ± 3'			-	2 OF 5	A3	
MATERIAL SEE NOTE	FINISH SEE NOTE					

THIS DRAWING IS UNPUBLISHED.

RELEASED FOR PUBLICATION

ALL RIGHTS RESERVED.

© COPYRIGHT - By -

LOC	DIST	REVISIONS			
P	LTR	DESCRIPTION	DATE	DWN	APVD
-	-	SEE SHEET 1	-	-	-

HEADER(P=2.00)
DUAL ROW SERIES(1.50)

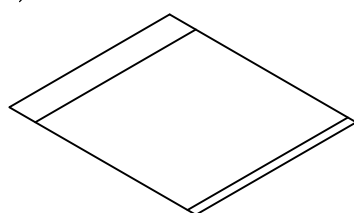
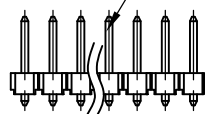

BUSINESS
ESTABLISHMENT LABEL

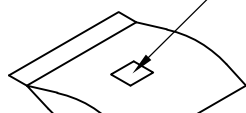

LABEL

BAG
140MM(L)X110MM(W)

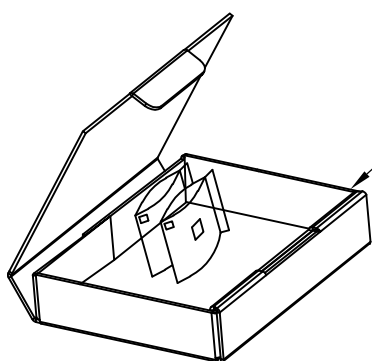
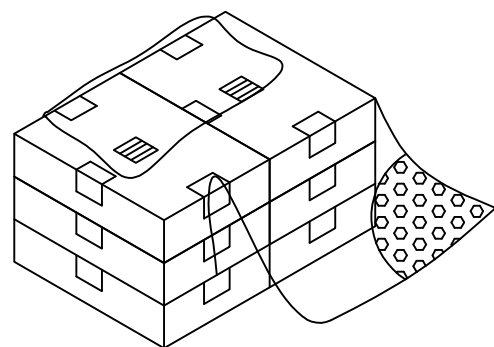

INNER CARTON

1 EACH BAG SHALL BE INCLUDED:
* DESICCANT

2 DIMENSIONS:
CARTON:490*394*245MM
INNER CARTON:B3B,218*185*80MM
PE BAG:140*110*0.08MM

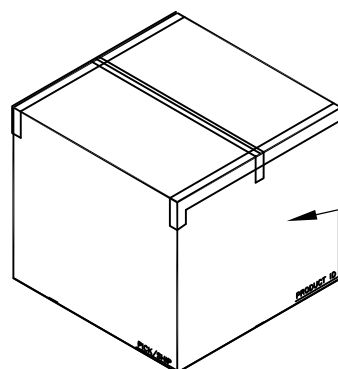
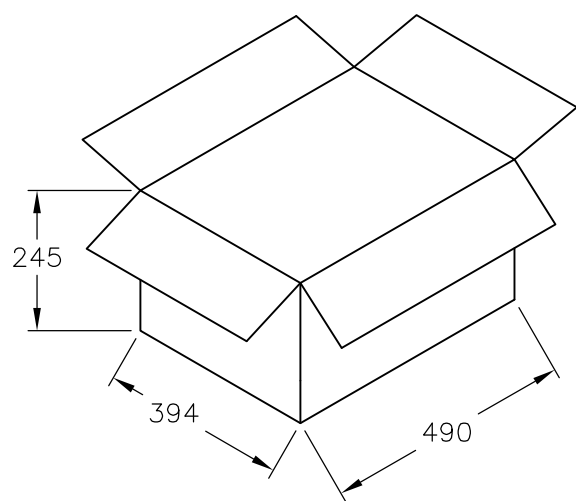

BOX

7.96 KG	5.18 KG	600	8	6	28800 PCS	10	2041051-2
7.1 KG	4.32 KG	300	8	6	14400 PCS	10	2041051-1
GROSS WEIGHT	NET WEIGHT	PCS/BAG	BAGS /INNER CARTON	INNER CARTON /CARTON	QUANTITY	NO. OF POSTS	PART NUMBER

THIS DRAWING IS A CONTROLLED DOCUMENT.		DWN	TE Connectivity				
DIMENSIONS: mm		CHK	NAME				
		APVD	AMPMODU 2.00MM PITCH POST HDR VERTICAL MOUNT TYPE				
TOLERANCES UNLESS OTHERWISE SPECIFIED:		PRODUCT SPEC	-				
0 PLC ± -		APPLICATION SPEC	-				
1 PLC ± -		WEIGHT	-				
2 PLC ± -		CUSTOMER DRAWING	SCALE	SHEET	REV	RESTRICTED TO	
3 PLC ± -		A3	-	3 OF 5	A3	-	
4 PLC ± -		00779	C=2041051		-		
ANGLES ± -		-					
FINISH		-					

THIS DRAWING IS UNPUBLISHED. RELEASED FOR PUBLICATION
 © COPYRIGHT - By - ALL RIGHTS RESERVED.

LOC	DIST	REVISIONS					
		P	LTR	DESCRIPTION	DATE	DWN	APVD
-	-	-	-	SEE SHEET 1	-	-	-

- MATERIAL :
 COVER TAPE : PT+ABS, COLOR: TRANSPARENT
 CARRIER TAPE : PS
 REEL : PS
 SHIPPING BOX: CORRUGATED FIBER
- PEELING RESISTANCE : 10gf~130gf (for 12mm~56mm)
- PEELING SPEED : 300mm/MINUTES

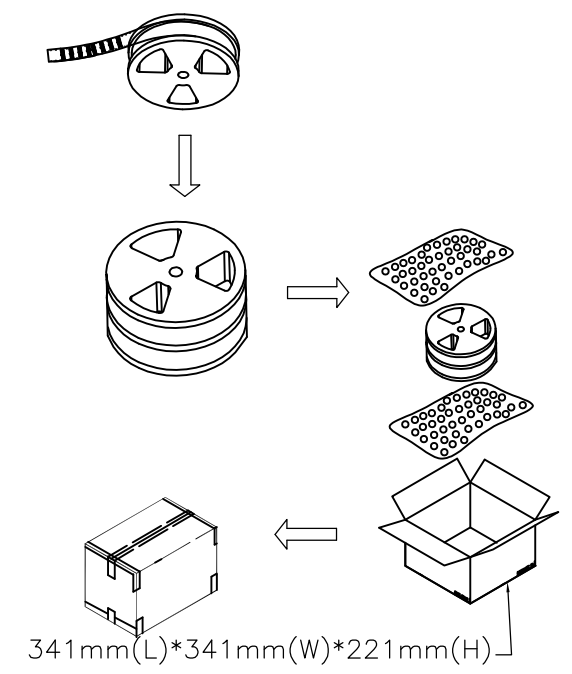
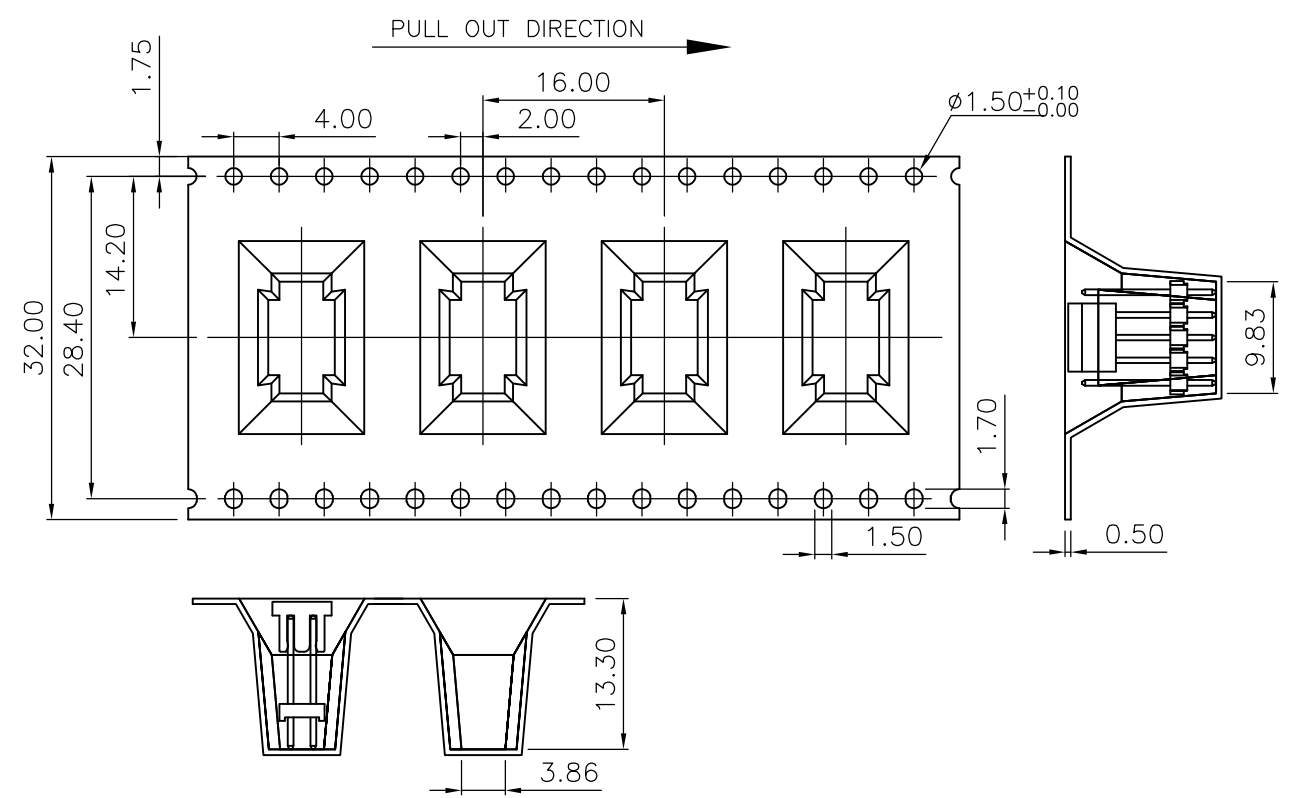
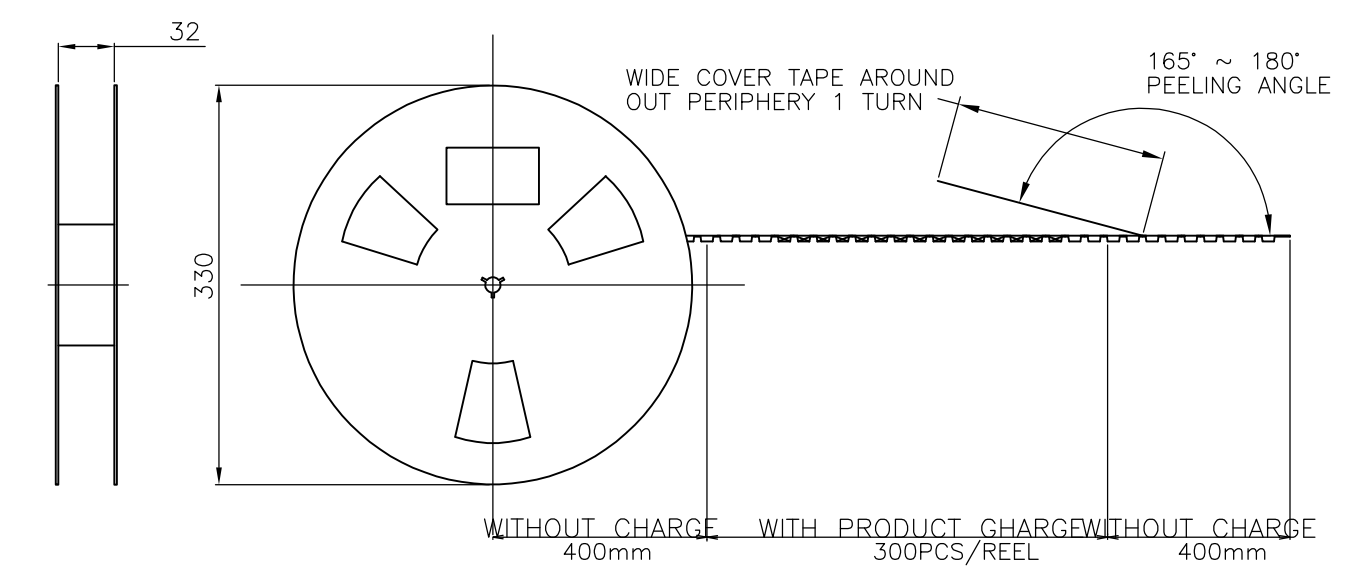

3.02 KG	0.50 KG	1250	250	10	1-2041051-4
3.02 KG	0.47 KG	1250	250	10	1-2041051-3
3.02 KG	0.60 KG	1250	250	10	2041051-3
GROSS WEIGHT	NET WEIGHT	PCS/CARTON	PCS/REEL	NO. OF POSTS	PART NUMBER

THIS DRAWING IS A CONTROLLED DOCUMENT.

DIMENSIONS: mm	TOLERANCES UNLESS OTHERWISE SPECIFIED:	DWN	TE Connectivity			
0 PLC ± - 1 PLC ± - 2 PLC ± - 3 PLC ± - 4 PLC ± - ANGLES ± -	FINISH	CHK	NAME			
MATERIAL		APVD	AMPMODU 2.00MM PITCH POST HDR VERTICAL MOUNT TYPE			
		PRODUCT SPEC	SIZE	CAGE CODE	DRAWING NO	RESTRICTED TO
		APPLICATION SPEC	A3	00779	C-2041051	
		WEIGHT	CUSTOMER DRAWING		SCALE	SHEET 4 OF 5 REV A3

THIS DRAWING IS UNPUBLISHED. RELEASED FOR PUBLICATION
 © COPYRIGHT - By - ALL RIGHTS RESERVED.

LOC	DIST	REVISIONS					
		P	LTR	DESCRIPTION	DATE	DWN	APVD
-	-	-	-	SEE SHEET 1	-	-	-

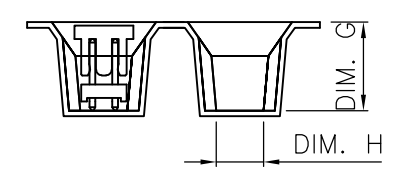
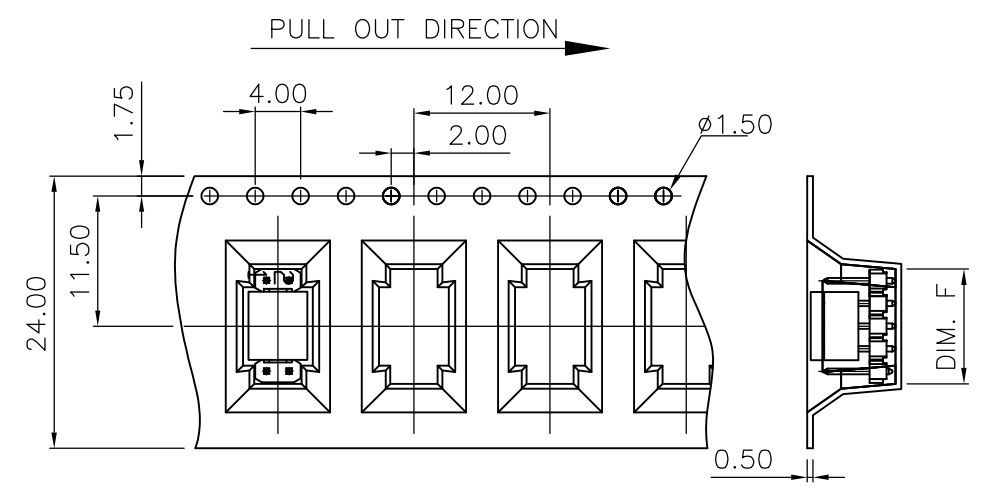
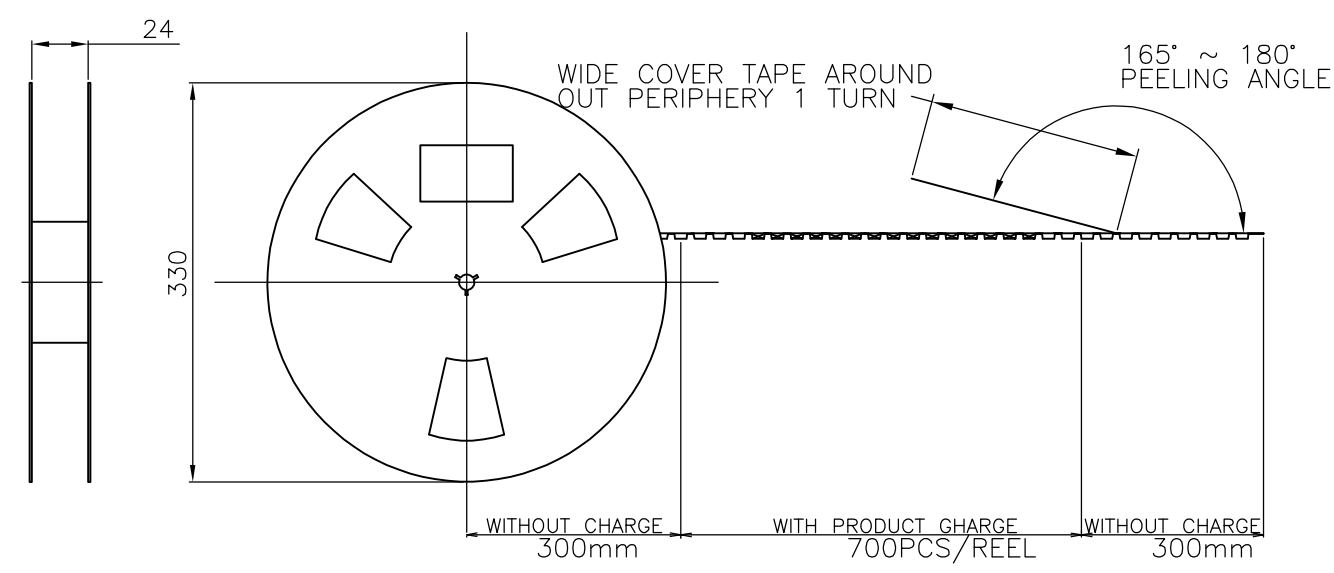

- MATERIAL :
COVER TAPE : PT+ABS, COLOR: TRANSPARENT
CARRIER TAPE : PS
REEL : PS
SHIPPING BOX: CORRUGATED FIBER
- PEELING RESISTANCE : 10gf~130gf (for 12mm~56mm)
- PEELING SPEED : 300mm/MINUTES

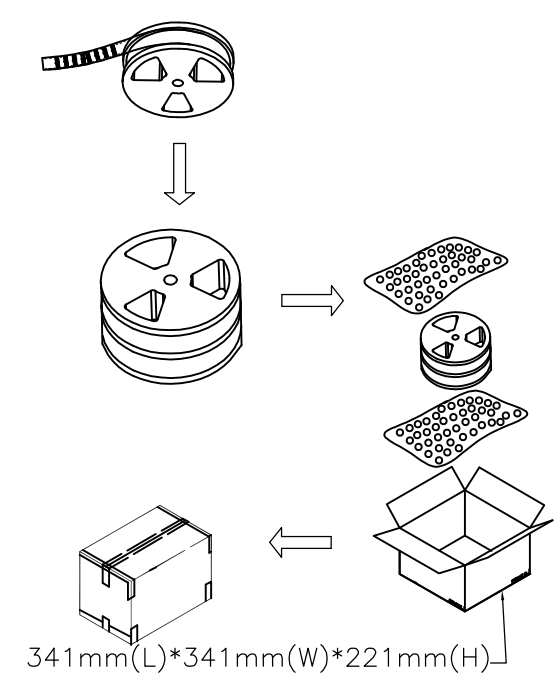

3.86	10.10	9.82	3.95 KG	1.05 KG	2400	400	10	1-2041051-2
4.16	7.80	10.12	4.34 KG	1.44 KG	4200	700	10	2041051-4
DIM.H	DIM.G	DIM.F	GROSS WEIGHT	NET WEIGHT	PCS/CARTON	PCS/REEL	NO. OF POSTS	PART NUMBER

THIS DRAWING IS A CONTROLLED DOCUMENT.		DWN	TE Connectivity AMPMODU 2.00MM PITCH POST HDR VERTICAL MOUNT TYPE				
DIMENSIONS: mm		CHK					
TOLERANCES UNLESS OTHERWISE SPECIFIED:		APVD					
0 PLC ± - 1 PLC ± - 2 PLC ± - 3 PLC ± - 4 PLC ± - ANGLES ± -		PRODUCT SPEC					
MATERIAL		FINISH	APPLICATION SPEC	SIZE	CAGE CODE	DRAWING NO	RESTRICTED TO
			WEIGHT	A3	00779	C-2041051	
CUSTOMER DRAWING			SCALE	SHEET	5 OF 5	REV	A3

单击下面可查看定价，库存，交付和生命周期等信息

[>>TE Connectivity\(泰科\)](#)