

THIS DRAWING IS UNPUBLISHED. RELEASED FOR PUBLICATION 20
 © COPYRIGHT 20 BY - ALL RIGHTS RESERVED.

LOC	DIST	REVISIONS					
GP	00	P	LTR	DESCRIPTION	DATE	DWN	APVD
		A		RELEASE	31DEC2015	JY	SH
		A1		REVISED PER ECO-19-016043	21OCT2019	SH	SH

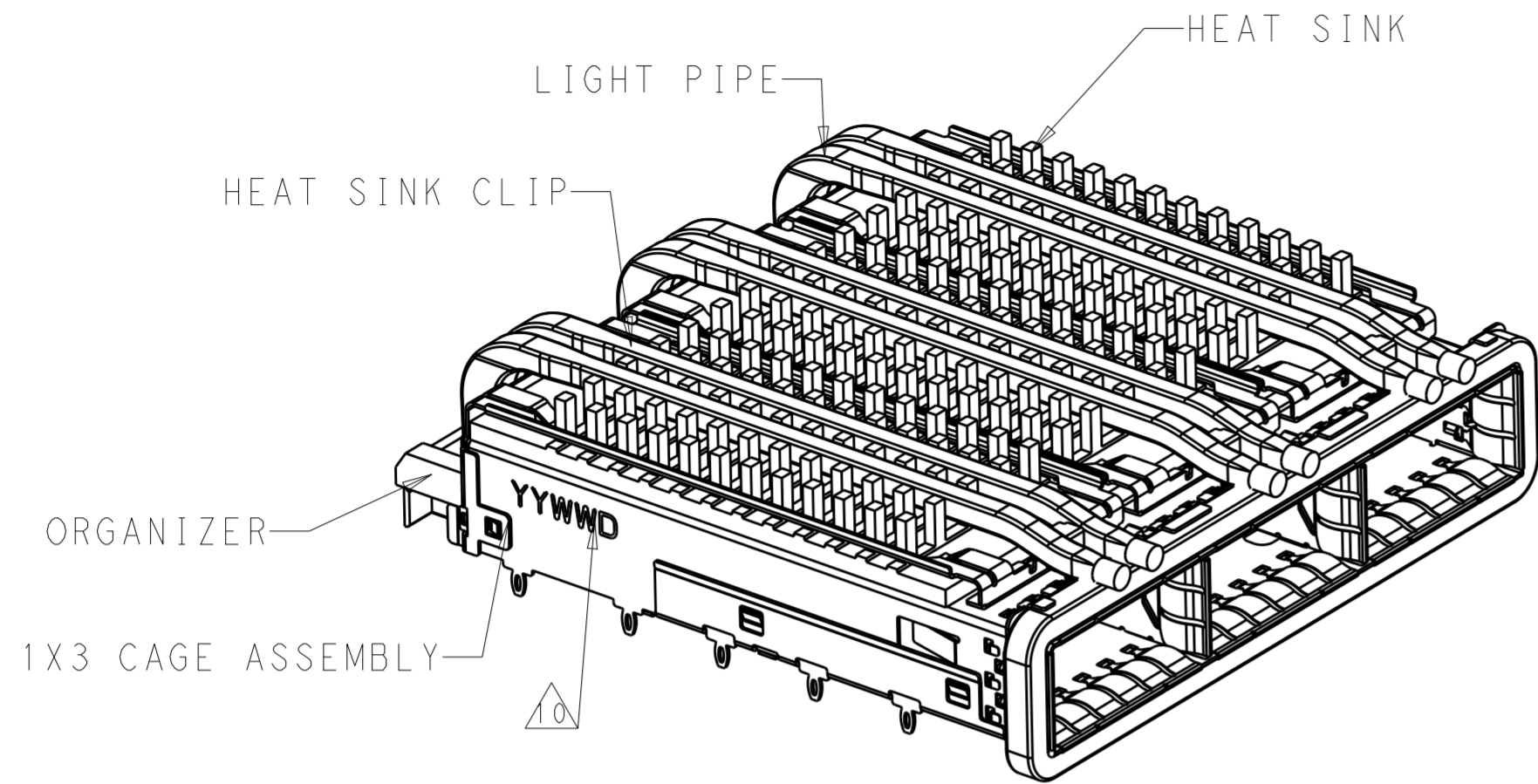

2-2170769-2 AS SHOWN
SCALE 2:1

- COMPONENTS
 CAGE ASSEMBLY: NICKEL-SILVER ALLOY
 HEAT SINK: ALUMINUM/BLACK ANODIZE
 HEAT SINK CLIP: STAINLESS STEEL
 EMI SPRING: COPPER ALLOY/NICKEL PLATE
 LIGHT PIPE: CLEAR POLYCARBONATE
 ORGANIZER: POLYESTER
- REFERENCE APPLICATION SPECIFICATION 114-32023 FOR RECOMMENDED DRILL HOLE DIAMETER AND PLATING THICKNESS

- DATUM AND BASIC DIMENSION ESTABLISHED BY CUSTOMER
- DIMENSION APPLIES WITH MODULE INSERTED IN CAGE

- HEAT SINKS, HEAT SINK CLIPS AND LIGHT PIPES ARE SHIPPED ASSEMBLED ON CAGE
- MINIMUM PC BOARD THICKNESS:
 SINGLE SIDED: 1.57 MIN
 DOUBLE SIDED: 3.00 MIN

- DATUM [-A-] IS TOP SURFACE OF THE HOST BOARD.
- THESE HOLES ARE OPTIONAL WHEN THE REAR PINS ARE REMOVED.
- MATES WITH QSFP28 MSA COMPATIBLE TRANSCEIVER.
- DATE CODE (YYWWD) MARKED APPROXIMATELY AS SHOWN.
- NOTED DIMENSIONS ONLY APPLY TO CAGE ASSEMBLY WITH LIGHT PIPE.

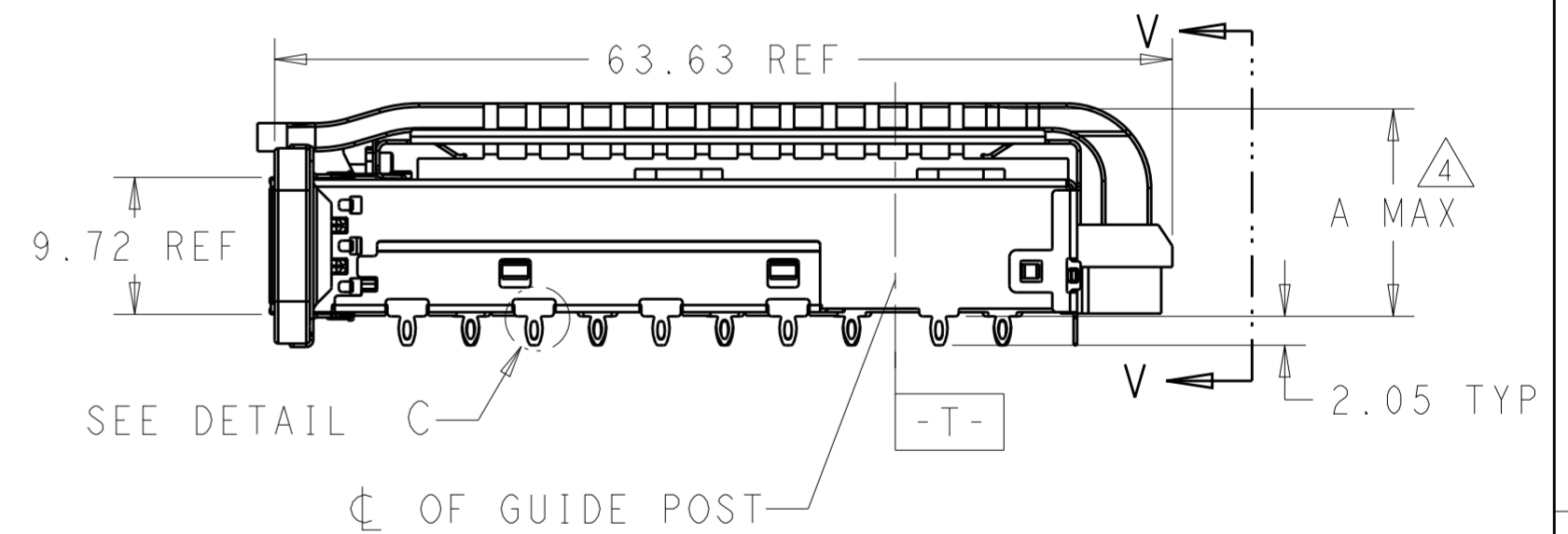
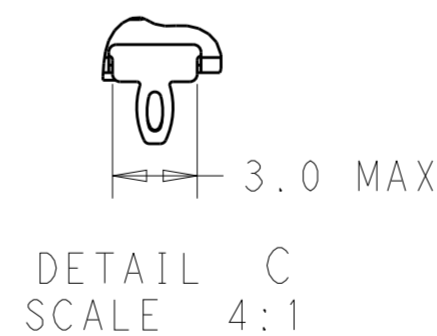
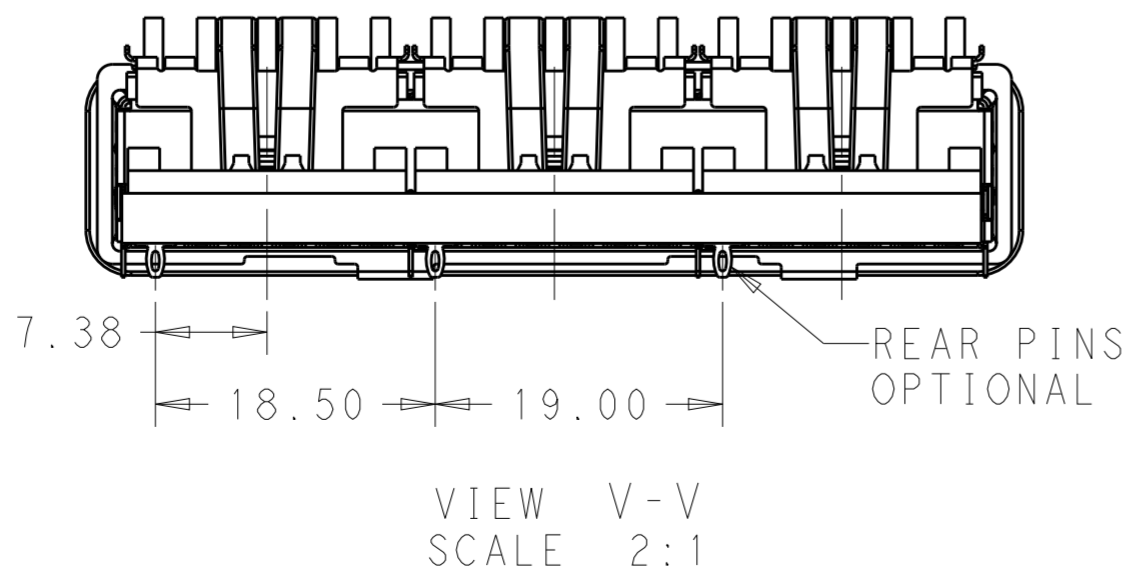
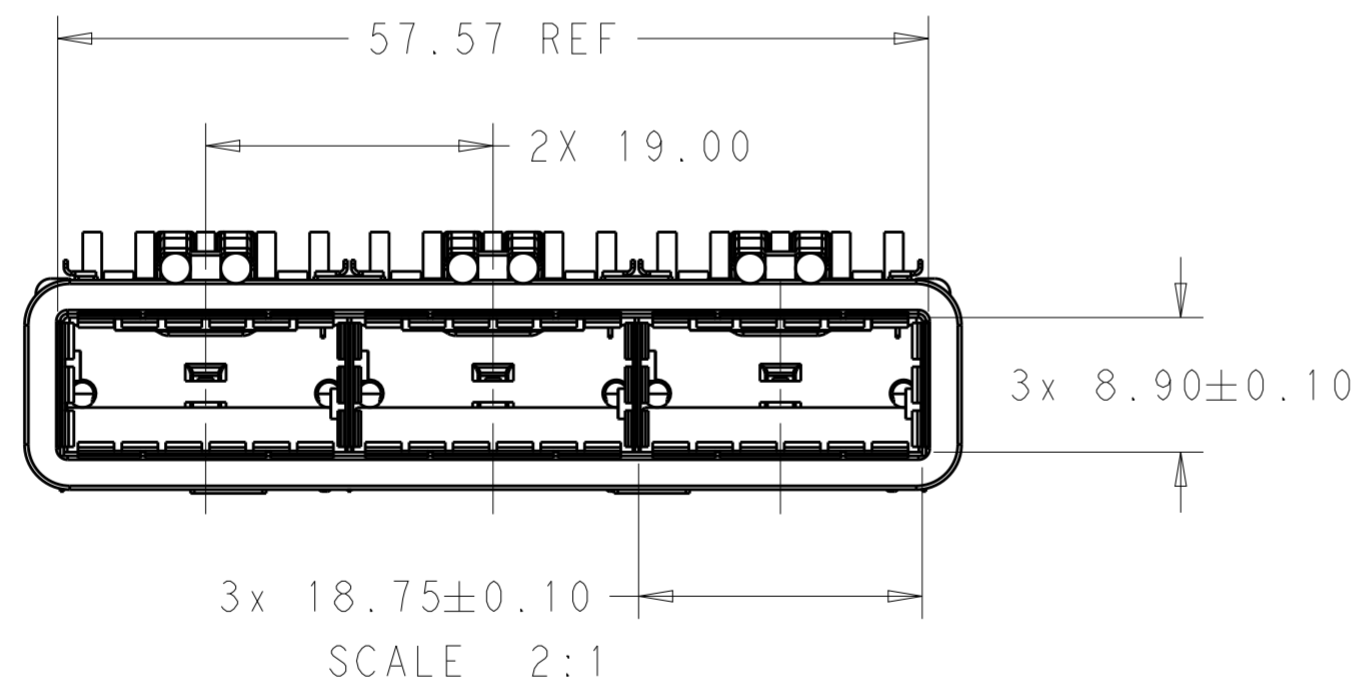

THIS DRAWING IS A CONTROLLED DOCUMENT.		DWN BING LIU 23APR2014	STE TE Connectivity	
		CHK JASON YANG 23APR2014		
DIMENSIONS: mm		APVD SEAN HAN 31DEC2015	NAME RECEPTACLE CAGE ASSEMBLY WITH HEAT SINKS AND LIGHT PIPES, THRU BEZEL, 1X3, QSFP28	
TOLERANCES UNLESS OTHERWISE SPECIFIED:		PRODUCT SPEC 108-19428	SIZE CAGE CODE DRAWING NO RESTRICTED TO	
0 PLC ±		APPLICATION SPEC 114-32023	A200779 C-2170769	
1 PLC ±0.25		WEIGHT -	SCALE 3:1 SHEET 1 OF 9 REV A1	
2 PLC ±0.2		CUSTOMER DRAWING		
3 PLC ±				
4 PLC ±				
ANGLES ±				
FINISH ±				
SEE NOTES		SEE NOTES		

THIS DRAWING IS UNPUBLISHED. RELEASED FOR PUBLICATION 20
 © COPYRIGHT 20 BY - ALL RIGHTS RESERVED.

LOC		DIST		REVISIONS			
P	LTR	DESCRIPTION		DATE	DWN	APVD	
-		SEE SHEET 1		-	-	-	

HEAT SINK OPTION

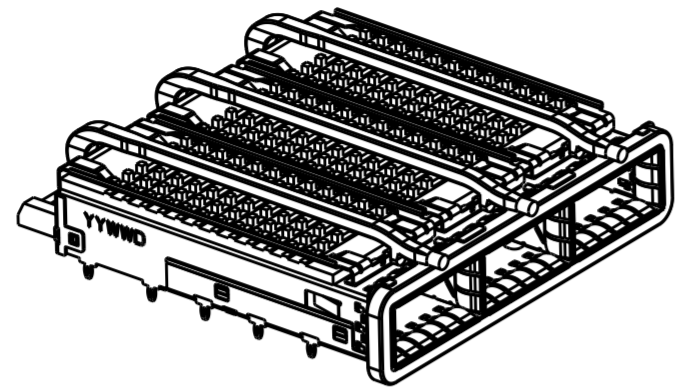

SCALE 1:1

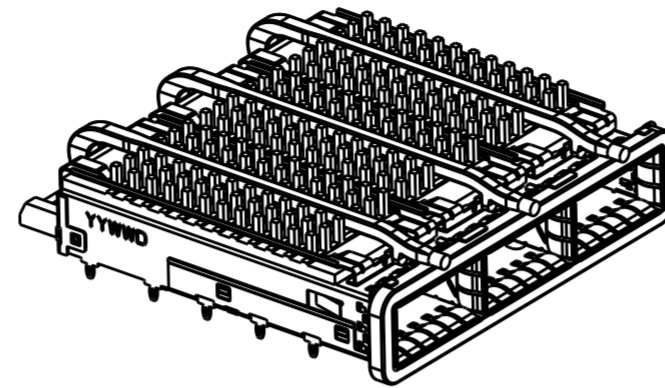

SCALE 1:1

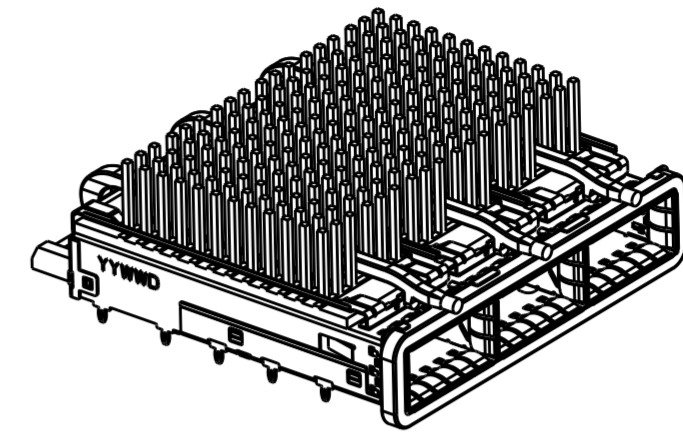

SCALE 1:1

LIGHT PIPE OPTION

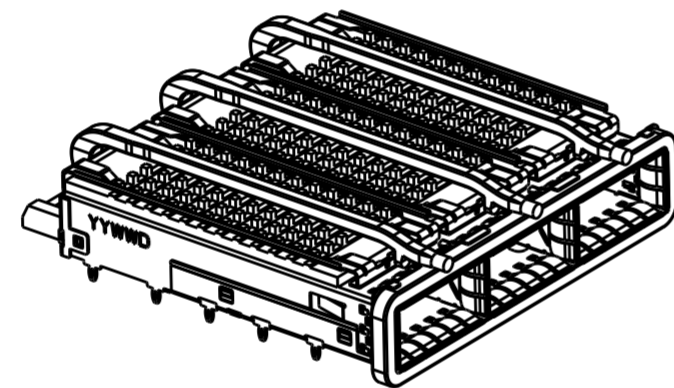

SCALE 1:1

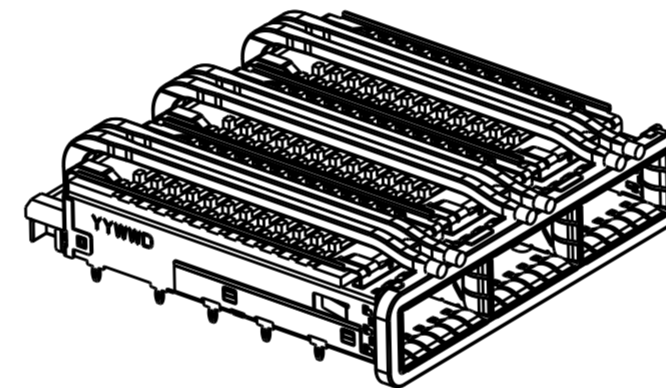

SCALE 1:1

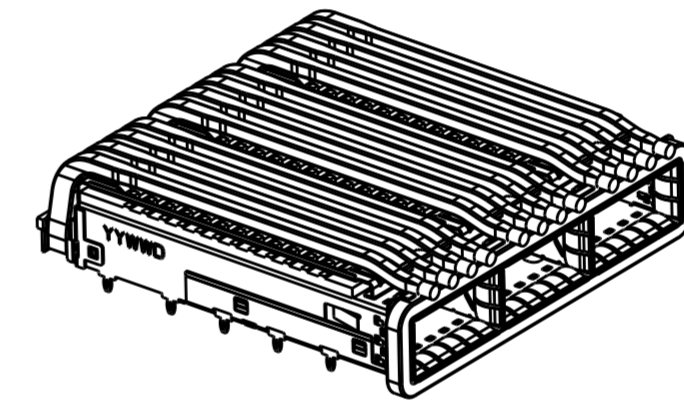

SCALE 1:1

OF REAR PIN OPTION

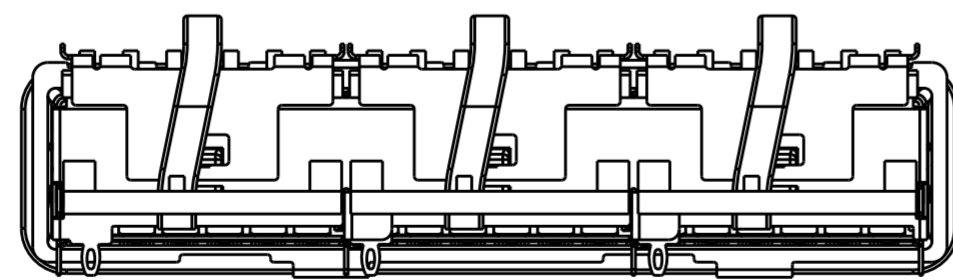

1 REAR PIN
SCALE 2:1

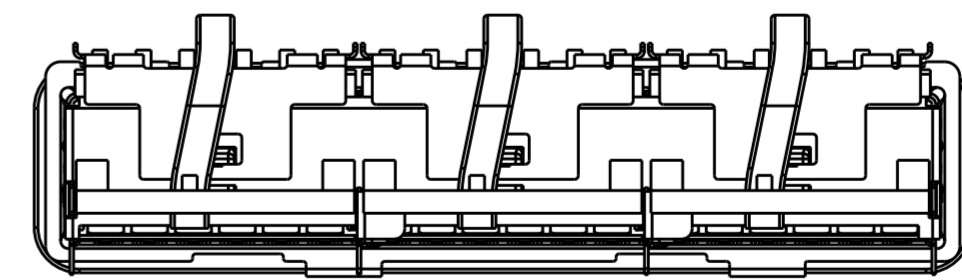

0 REAR PIN
SCALE 2:1

THIS DRAWING IS A CONTROLLED DOCUMENT.		DWN BING LIU 23APR2014	TE Connectivity
DIMENSIONS: mm		CHK JASON YANG 23APR2014	
TOLERANCES UNLESS OTHERWISE SPECIFIED:		APVD SEAN HAN 31DEC2015	NAME RECEPTACLE CAGE ASSEMBLY WITH HEAT SINKS AND LIGHT PIPES, THRU BEZEL, 1X3, QSFP28
		PRODUCT SPEC 108-19428	SIZE A2
MATERIAL SEE NOTES material_2		APPLICATION SPEC 114-32023	CAGE CODE 00779
FINISH SEE NOTES finish_spec_2		WEIGHT -	DRAWING NO C-2170769
		CUSTOMER DRAWING	RESTRICTED TO -
		SCALE 3:1	SHEET 1 OF 9
			REV A1

THIS DRAWING IS UNPUBLISHED. RELEASED FOR PUBLICATION 20
 © COPYRIGHT 20 BY - ALL RIGHTS RESERVED.

LOC	DIST	REVISIONS			
P	LTR	DESCRIPTION	DATE	DWN	APVD
	-	SEE SHEET 1	-	-	-

0	23.0	QUAD	NETWORKING	4-2170769-6
0	16.0	QUAD	SAN	4-2170769-5
0	13.7	QUAD	PCI	4-2170769-4
1	23.0	QUAD	NETWORKING	4-2170769-3
1	16.0	QUAD	SAN	4-2170769-2
1	13.7	QUAD	PCI	4-2170769-1
0	23.0	DUAL	NETWORKING	2-2170769-6
0	16.0	DUAL	SAN	2-2170769-5
0	13.7	DUAL	PCI	2-2170769-4
1	23.0	DUAL	NETWORKING	2-2170769-3
1	16.0	DUAL	SAN	2-2170769-2
1	13.7	DUAL	PCI	2-2170769-1
0	16.0	SINGLE	W/O HS	2170769-7
0	23.0	SINGLE	NETWORKING	2170769-6
0	16.0	SINGLE	SAN	2170769-5
0	13.7	SINGLE	PCI	2170769-4
1	23.0	SINGLE	NETWORKING	2170769-3
1	16.0	SINGLE	SAN	2170769-2
1	13.7	SINGLE	PCI	2170769-1
# OF REAR PIN	DIM A	LIGHT PIPE OPTION	APPLICATION	PART NUMBER

THIS DRAWING IS A CONTROLLED DOCUMENT.		DWN BING LIU 23APR2014	 TE Connectivity	
		CHK JASON YANG 23APR2014		
DIMENSIONS: mm		APVD SEAN HAN 31DEC2015	NAME RECEPTACLE CAGE ASSEMBLY WITH HEAT SINKS AND LIGHT PIPES, THRU BEZEL, 1X3, QSFP28	
TOLERANCES UNLESS OTHERWISE SPECIFIED: 0 PLC ± 1 PLC ±0.25 2 PLC ±0.2 3 PLC ± 4 PLC ± ANGLES ±		PRODUCT SPEC 108-19428	SIZE CAGE CODE DRAWING NO A200779 C-2170769	
MATERIAL SEE NOTES material_2		APPLICATION SPEC 114-32023	RESTRICTED TO -	
FINISH SEE NOTES finish_spec_2		WEIGHT -	SCALE 3:1 SHEET 1 OF 9 REV A1	
		CUSTOMER DRAWING		

THIS DRAWING IS UNPUBLISHED. RELEASED FOR PUBLICATION 20
 © COPYRIGHT 20 BY - ALL RIGHTS RESERVED.

LOC		DIST		REVISIONS			
P	LTR	DESCRIPTION		DATE	DWN	APVD	
-	-	SEE SHEET 1		-	-	-	

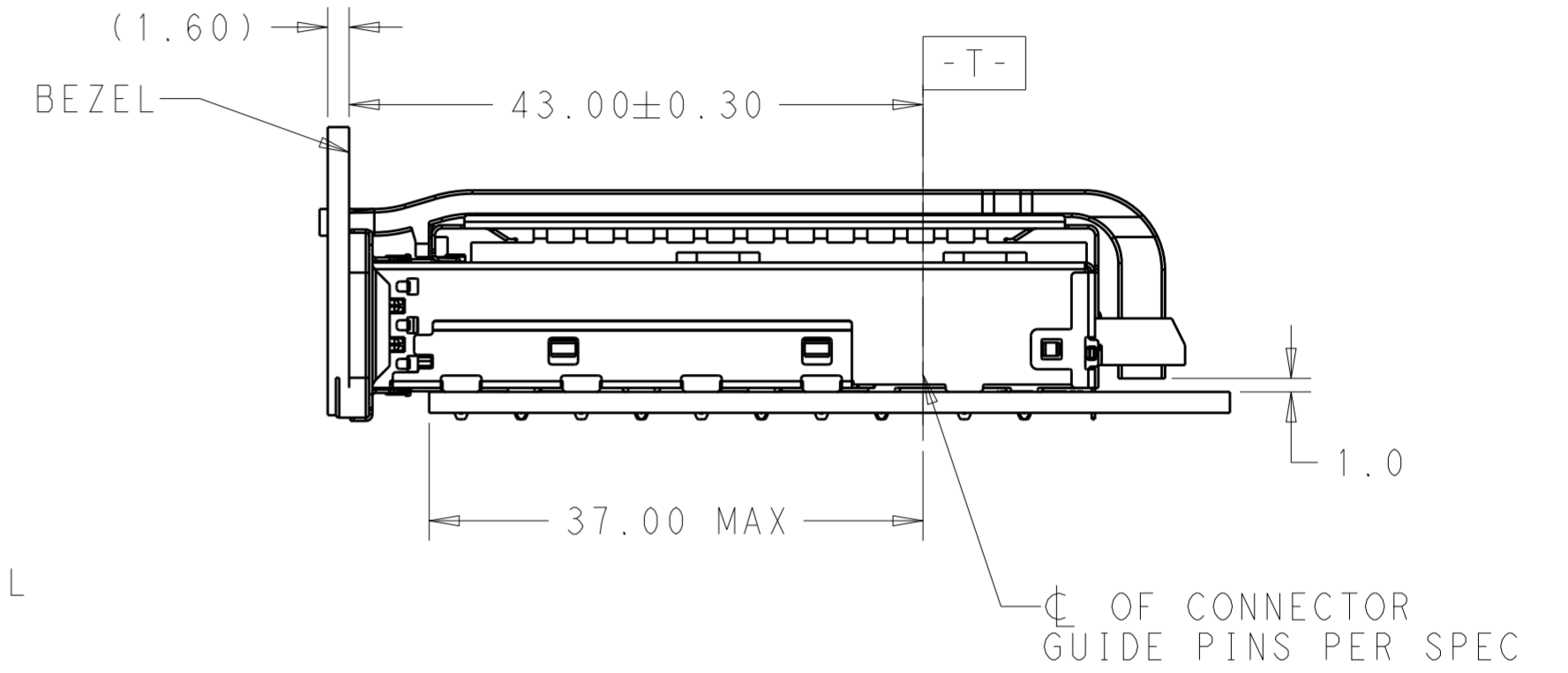
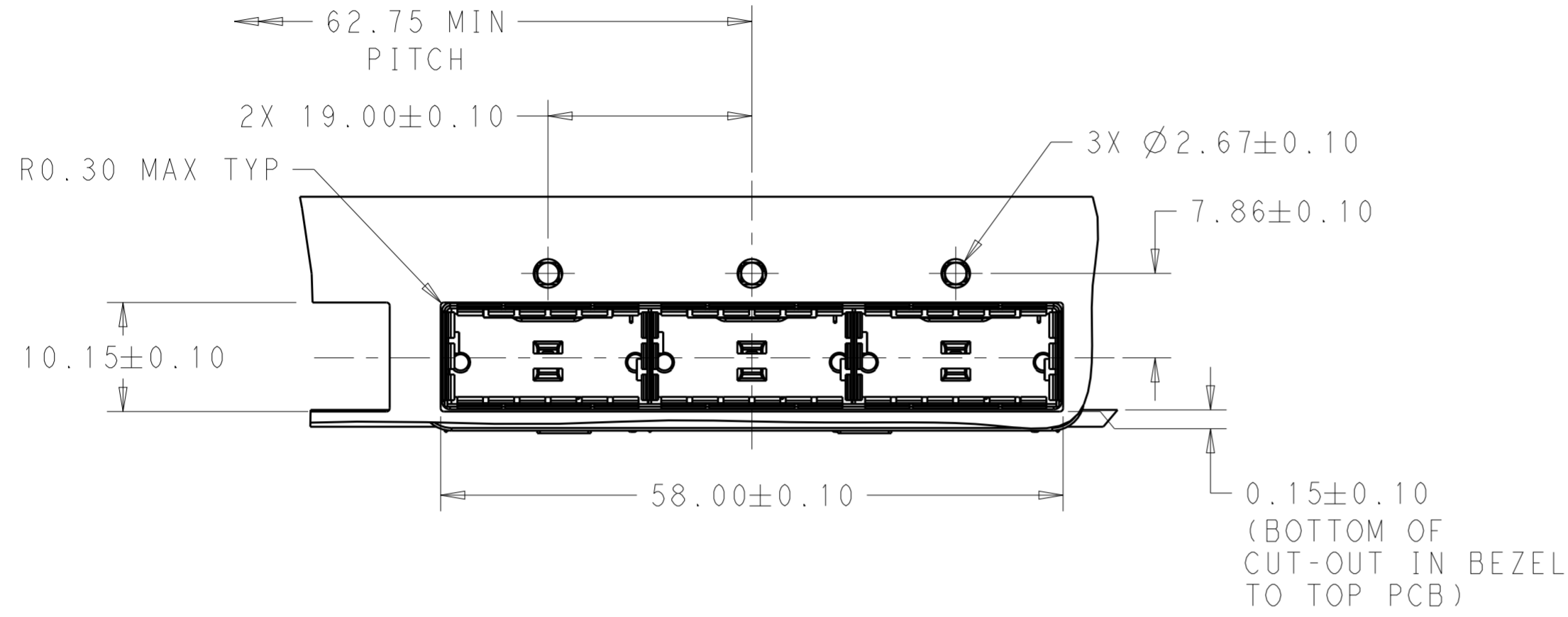

SINGLE SIDE MOUNTING
SCALE 2:1

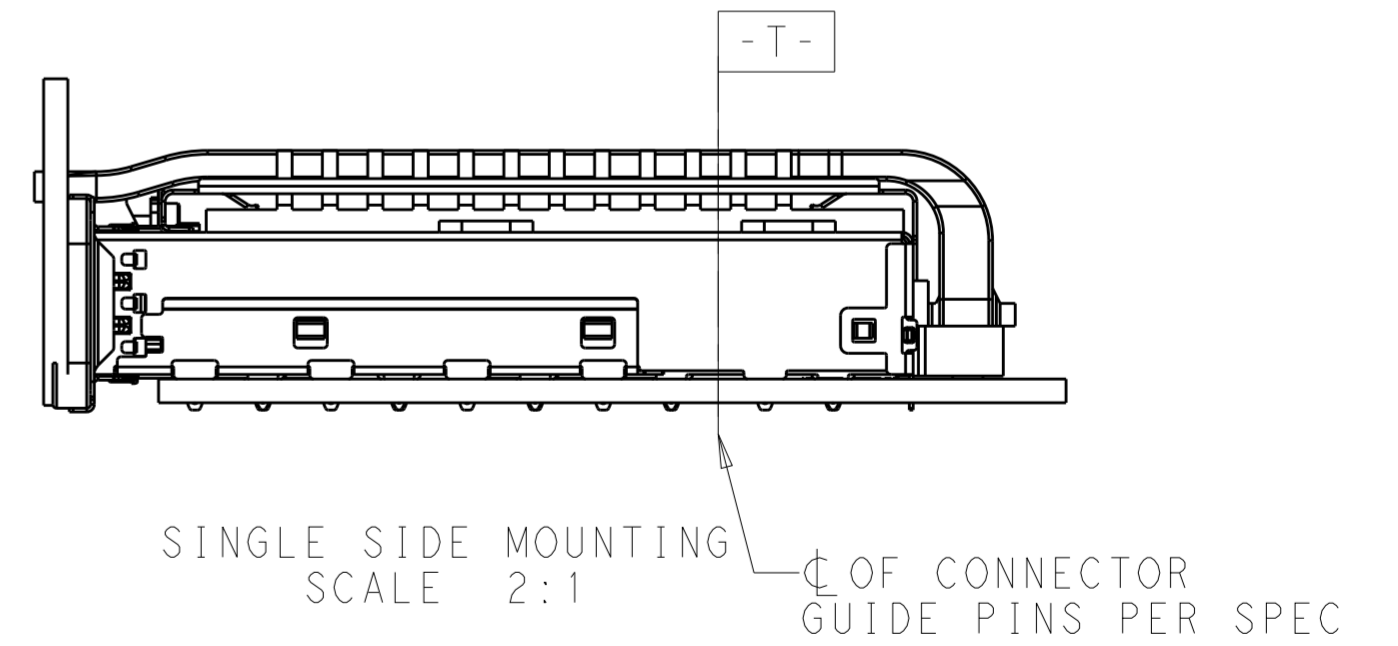
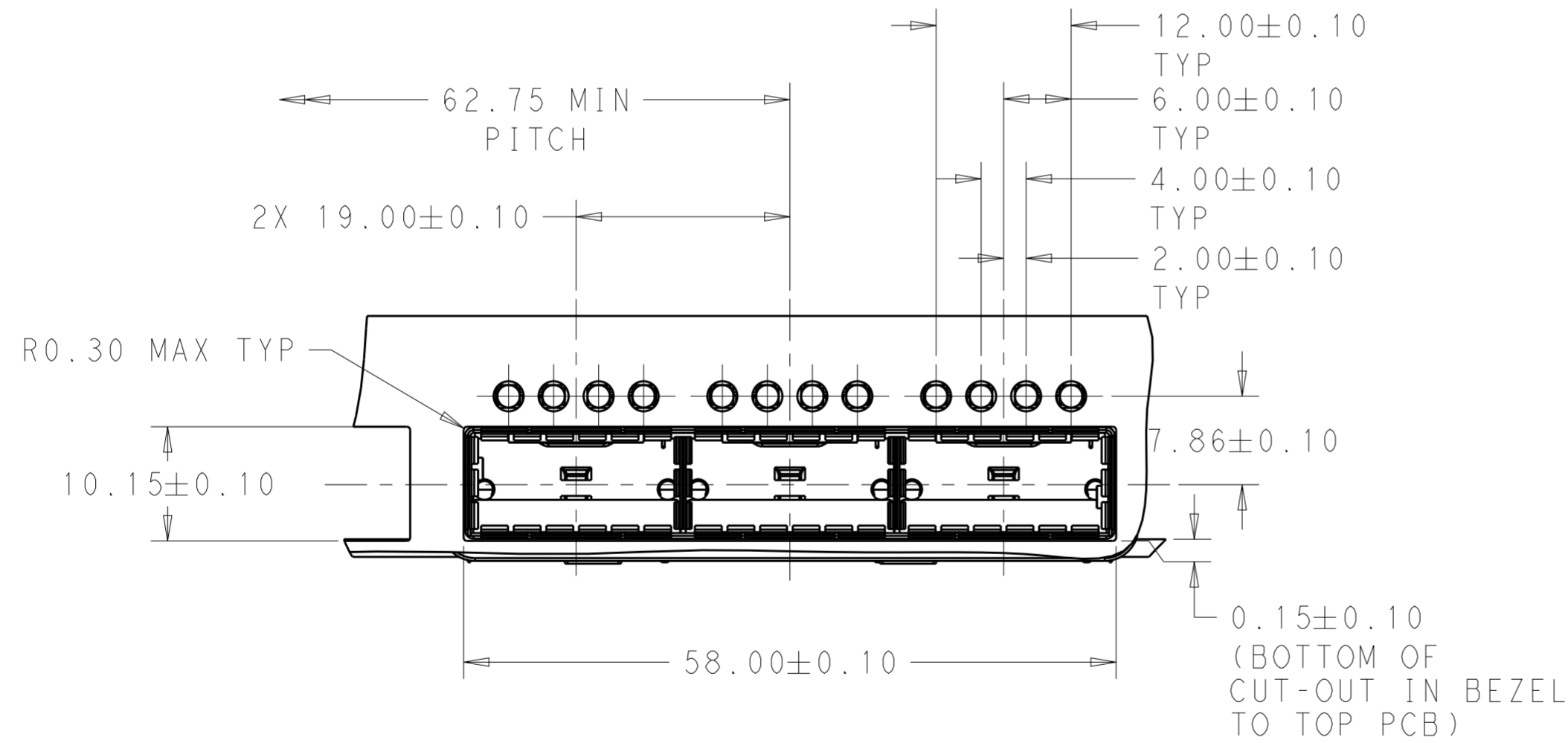

SINGLE SIDE MOUNTING
SCALE 2:1

THIS DRAWING IS A CONTROLLED DOCUMENT.		DWN BING LIU 23APR2014	TE Connectivity	
DIMENSIONS: mm		CHK JASON YANG 23APR2014		
TOLERANCES UNLESS OTHERWISE SPECIFIED:		APVD SEAN HAN 31DEC2015	NAME RECEPTACLE CAGE ASSEMBLY WITH HEAT SINKS AND LIGHT PIPES, THRU BEZEL, 1X3, QSFP28	
		PRODUCT SPEC 108-19428	SIZE A200779	
MATERIAL SEE NOTES material_2		APPLICATION SPEC 114-32023	DRAWING NO C-2170769	
FINISH SEE NOTES finish_spec_2		WEIGHT -	RESTRICTED TO -	
CUSTOMER DRAWING		SCALE 3:1	SHEET 1 OF 9 REV A1	

THIS DRAWING IS UNPUBLISHED. RELEASED FOR PUBLICATION 20
 © COPYRIGHT 20 BY - ALL RIGHTS RESERVED.

LOC	DIST	REVISIONS			
P	LTR	DESCRIPTION	DATE	DWN	APVD
-	-	SEE SHEET 1	-	-	-

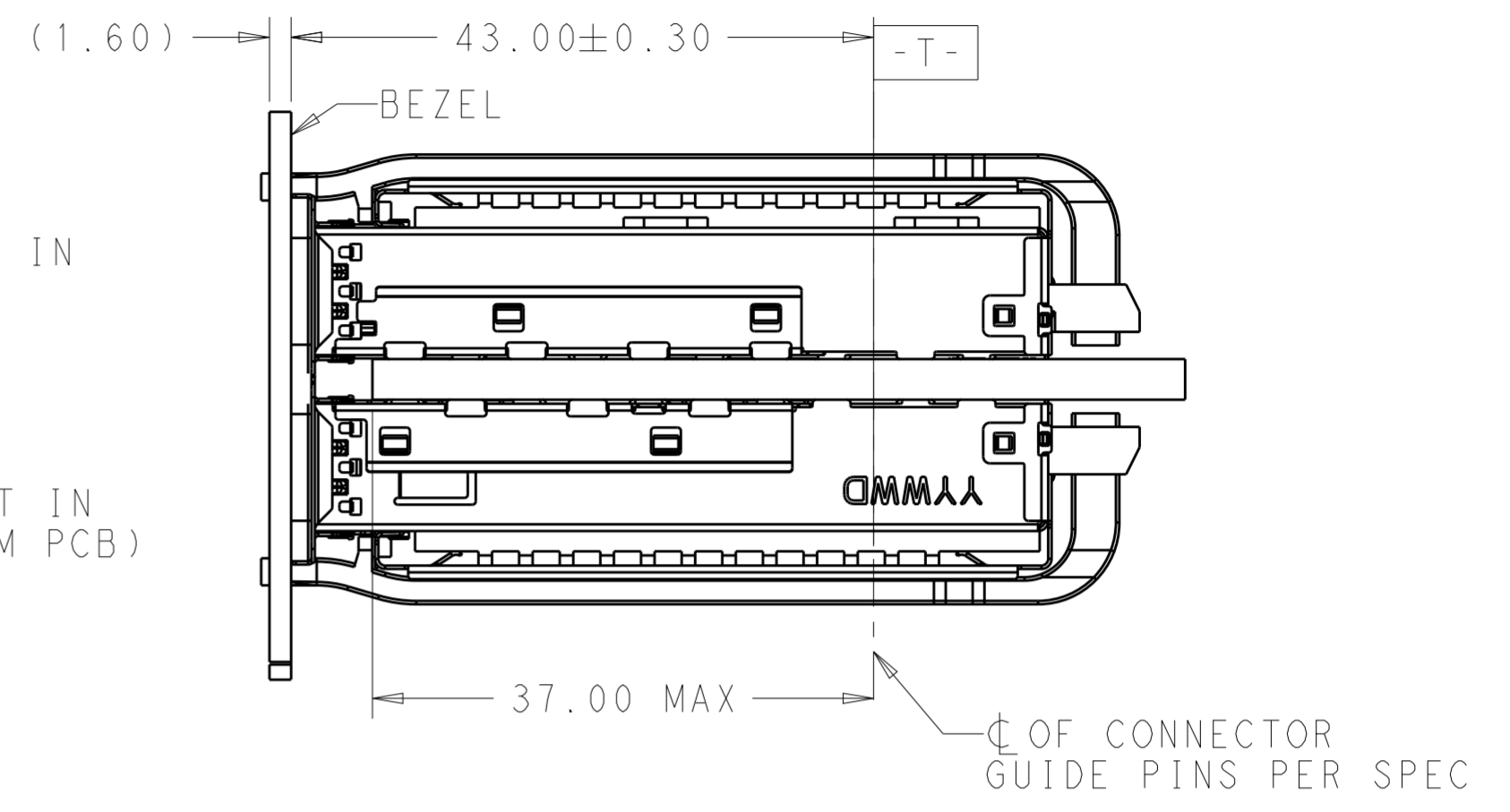
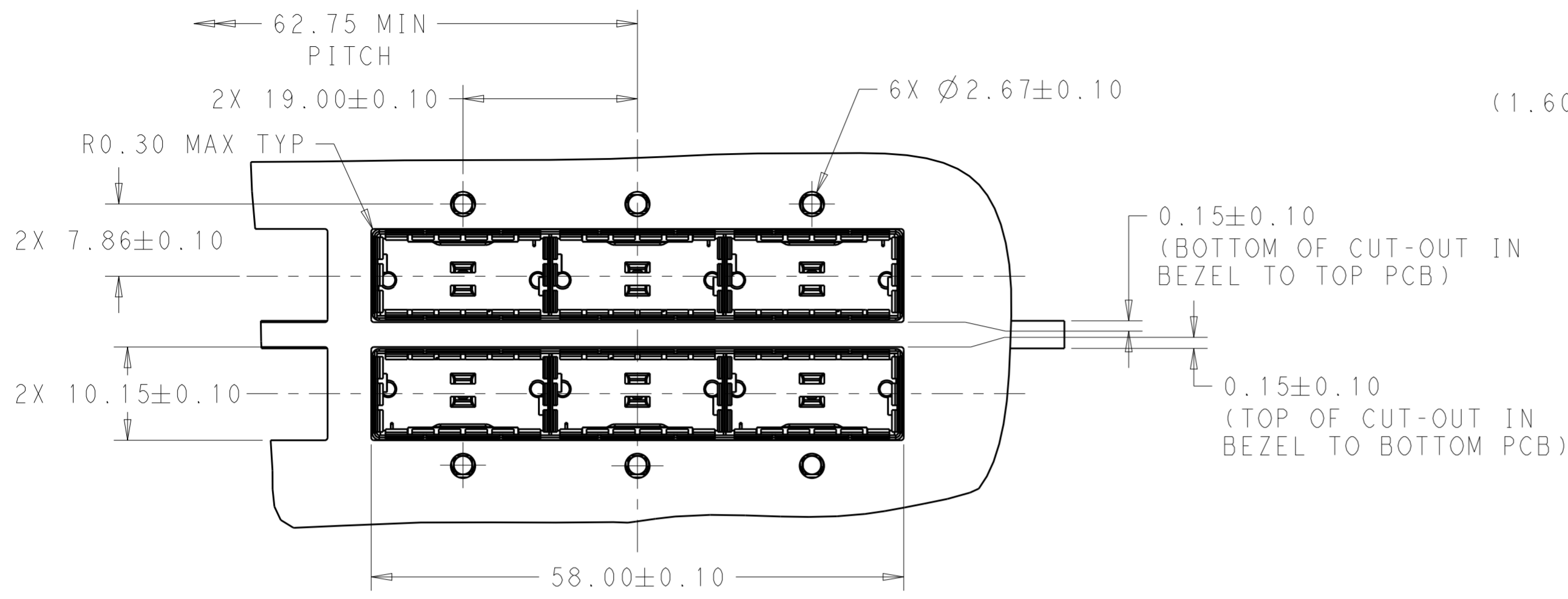

BELLY TO BELLY MOUNTING SCALE 2:1

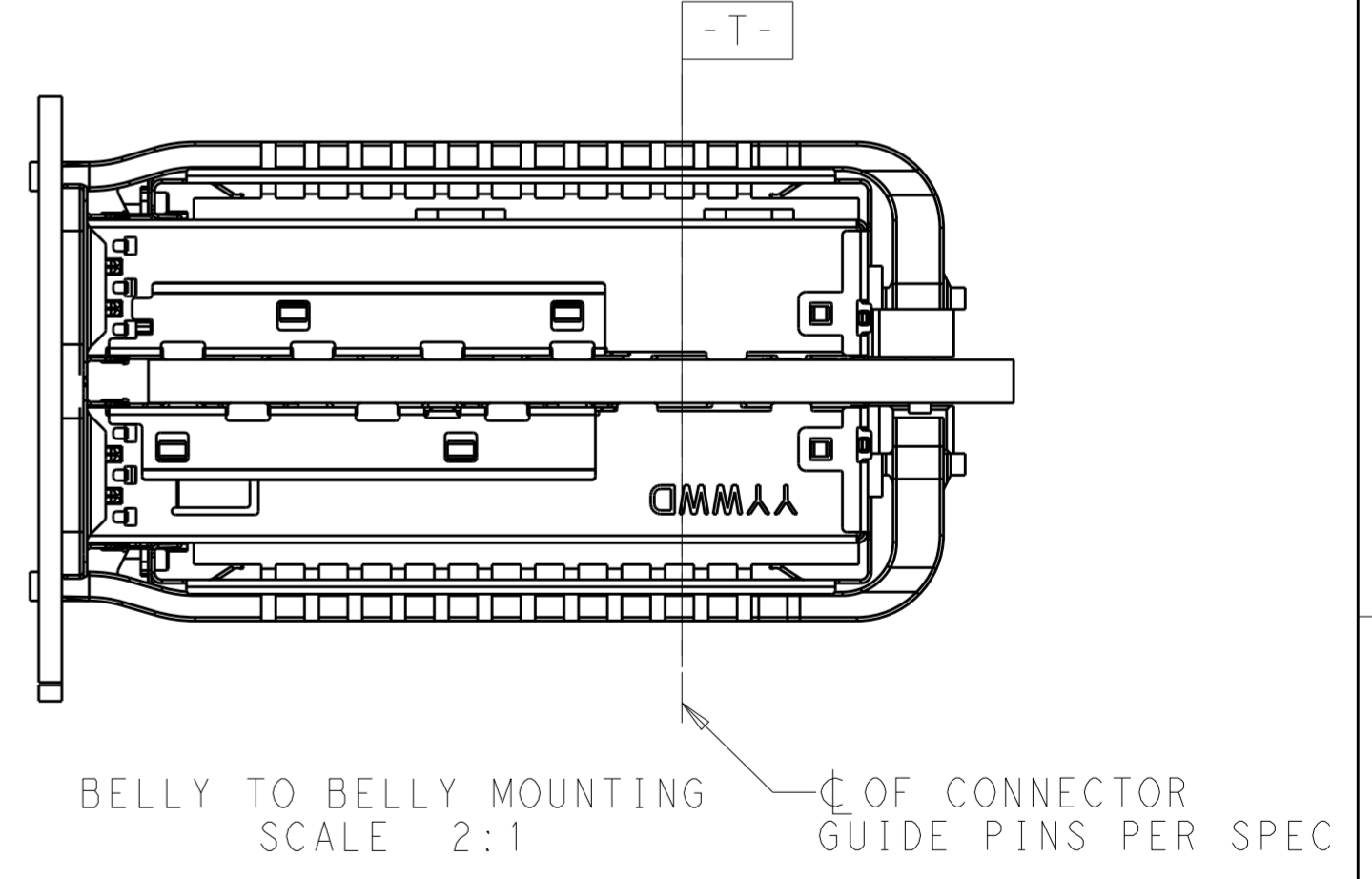
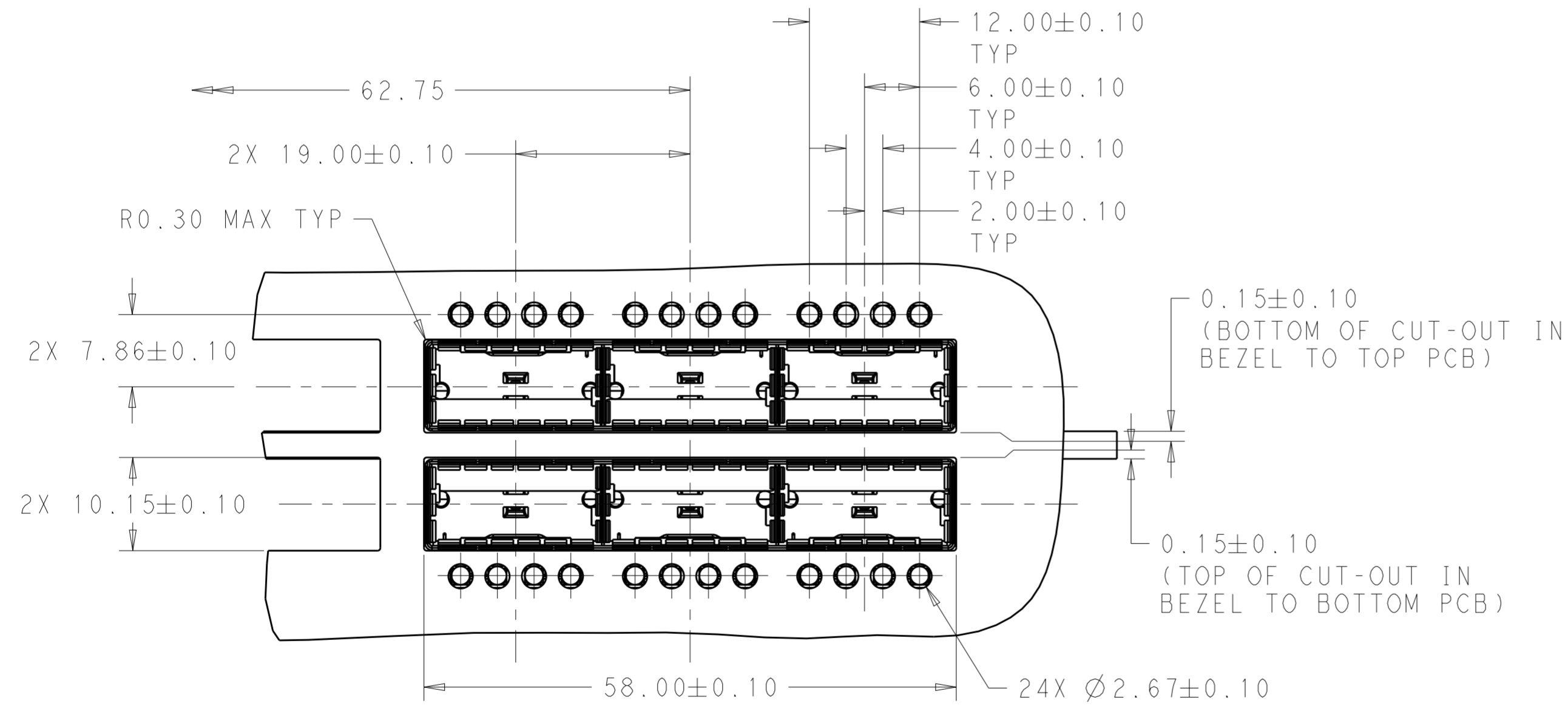

BELLY TO BELLY MOUNTING SCALE 2:1

THIS DRAWING IS A CONTROLLED DOCUMENT.		DWN BING LIU 23APR2014	TE Connectivity
DIMENSIONS: mm		CHK JASON YANG 23APR2014	
TOLERANCES UNLESS OTHERWISE SPECIFIED:		APVD SEAN HAN 31DEC2015	NAME RECEPTACLE CAGE ASSEMBLY WITH HEAT SINKS AND LIGHT PIPES, THRU BEZEL, 1X3, QSFP28
0 PLC ±		PRODUCT SPEC 108-19428	SIZE CAGE CODE DRAWING NO
1 PLC ±0.25		APPLICATION SPEC 114-32023	A200779 C-2170769
2 PLC ±0.2		WEIGHT -	RESTRICTED TO
3 PLC ±		CUSTOMER DRAWING	SCALE 3:1 SHEET 1 OF 9 REV A1
4 PLC ±			
ANGLES ±			
FINISH			
MATERIAL SEE NOTES material_2	SEE NOTES finish_spec_2		

THIS DRAWING IS UNPUBLISHED. RELEASED FOR PUBLICATION 20
 © COPYRIGHT 20 BY - ALL RIGHTS RESERVED.

LOC		DIST		REVISIONS			
P	LTR	DESCRIPTION	DATE	DWN	APVD		
-	-	SEE SHEET 1	-	-	-		

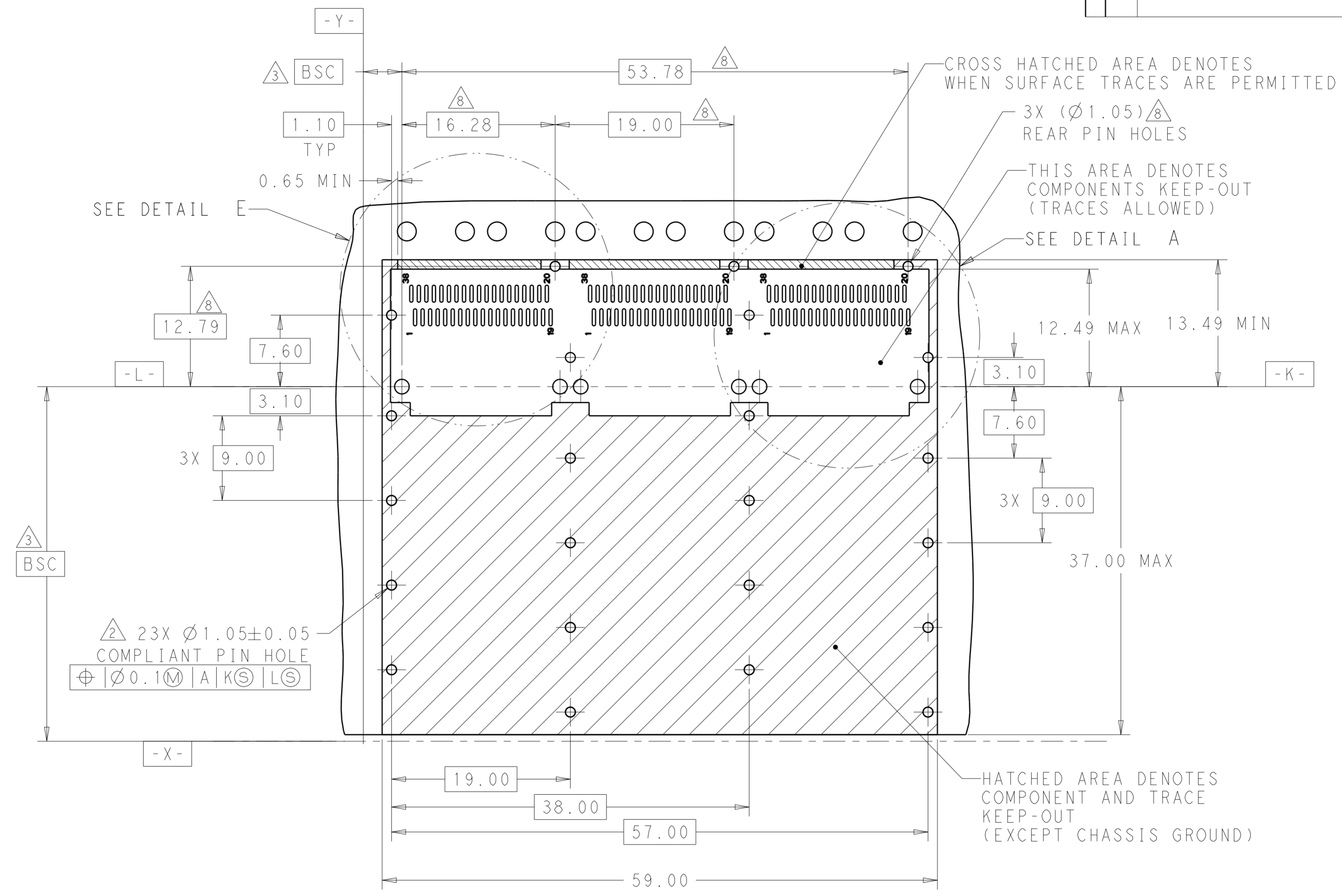

2 23X $\varnothing 1.05 \pm 0.05$
 COMPLIANT PIN HOLE
 $\varnothing 0.1$ M A K S L S

RECOMMENDED PCB LAYOUT
 SINGLE TYPE
 PCB TOLERANCE: ± 0.05
 SCALE 3:1

THIS DRAWING IS A CONTROLLED DOCUMENT.		DWN BING LIU 23APR2014	TE Connectivity	
DIMENSIONS: mm		CHK JASON YANG 23APR2014		
TOLERANCES UNLESS OTHERWISE SPECIFIED:		APVD SEAN HAN 31DEC2015	NAME RECEPTACLE CAGE ASSEMBLY WITH HEAT SINKS AND LIGHT PIPES, THRU BEZEL, 1X3, QSFP28	
0 PLC \pm		PRODUCT SPEC 108-19428	SIZE A200779	
1 PLC ± 0.25		APPLICATION SPEC 114-32023	DRAWING NO C-2170769	
2 PLC ± 0.2		WEIGHT -	RESTRICTED TO -	
3 PLC \pm		CUSTOMER DRAWING	SCALE 3:1 SHEET 1 OF 9 REV A1	
4 PLC \pm				
ANGLES \pm				
FINISH SEE NOTES material_2				

THIS DRAWING IS UNPUBLISHED. RELEASED FOR PUBLICATION 20
 © COPYRIGHT 20 BY - ALL RIGHTS RESERVED.

LOC		DIST		REVISIONS			
P	LTR	DESCRIPTION	DATE	DWN	APVD		
-	-	SEE SHEET 1	-	-	-		

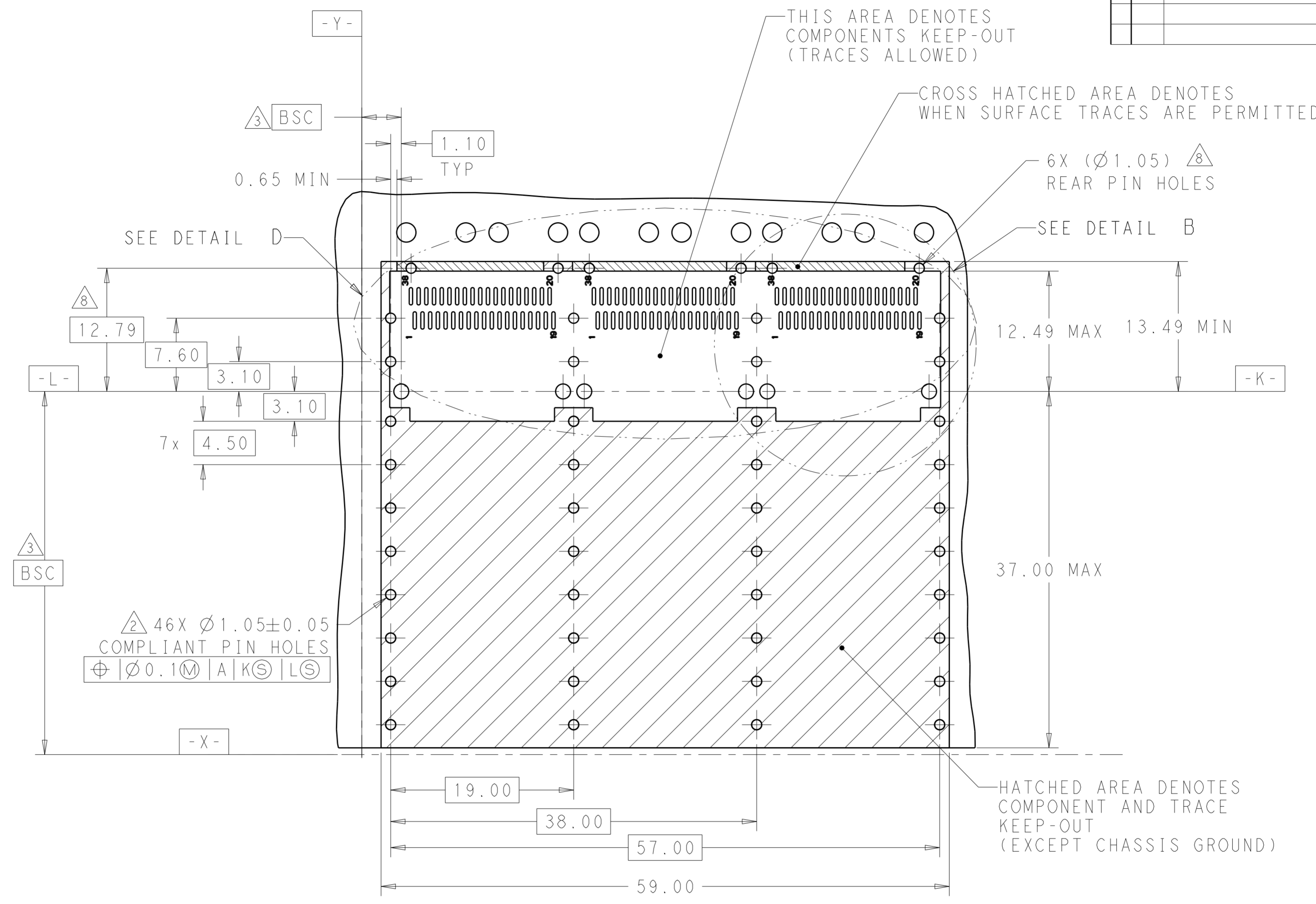

RECOMMENDED PCB LAYOUT
 BELLY TO BELLY TYPE
 PCB TOLERANCE: ±0.05
 SCALE 3:1

THIS DRAWING IS A CONTROLLED DOCUMENT.		DWN BING LIU 23APR2014	 TE Connectivity	
DIMENSIONS: mm		CHK JASON YANG 23APR2014		
TOLERANCES UNLESS OTHERWISE SPECIFIED:		APVD SEAN HAN 31DEC2015	NAME RECEPTACLE CAGE ASSEMBLY WITH HEAT SINKS AND LIGHT PIPES, THRU BEZEL, 1X3, QSFP28	
0 PLC ± 1 PLC ±0.25 2 PLC ±0.2 3 PLC ± 4 PLC ± ANGLES ±		PRODUCT SPEC 108-19428	SIZE A2	
MATERIAL SEE NOTES material_2		APPLICATION SPEC 114-32023	CAGE CODE 00779	DRAWING NO C-2170769
FINISH SEE NOTES finish_spec_2		WEIGHT -	RESTRICTED TO -	
CUSTOMER DRAWING		SCALE 3:1	SHEET 1	OF 9
		REV A1		

THIS DRAWING IS UNPUBLISHED. RELEASED FOR PUBLICATION 20
 © COPYRIGHT 20 BY - ALL RIGHTS RESERVED.

LOC		DIST		REVISIONS			
P	LTR	DESCRIPTION	DATE	DWN	APVD		
-	-	SEE SHEET 1	-	-	-		

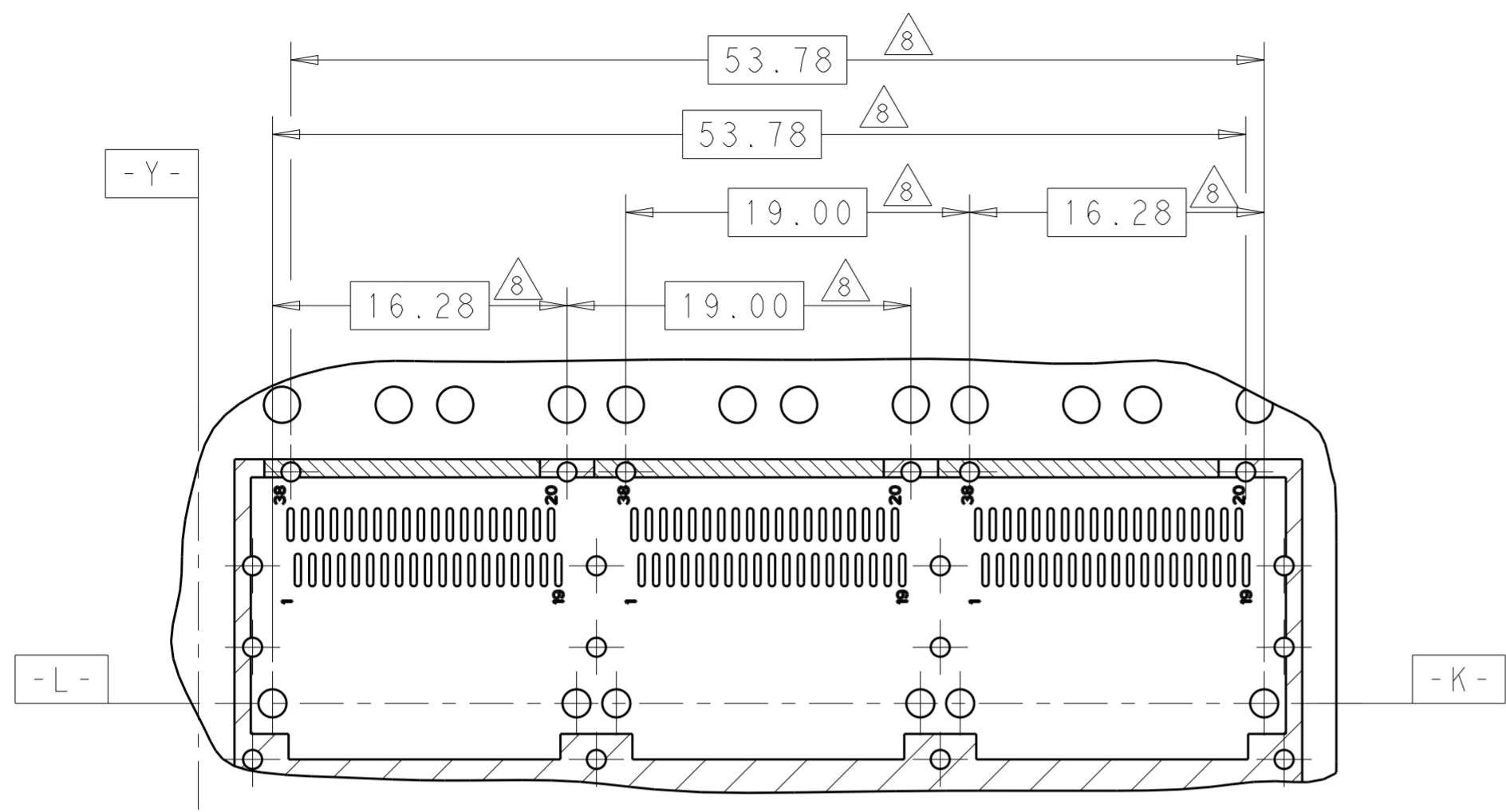

DETAIL D
SCALE 3:1

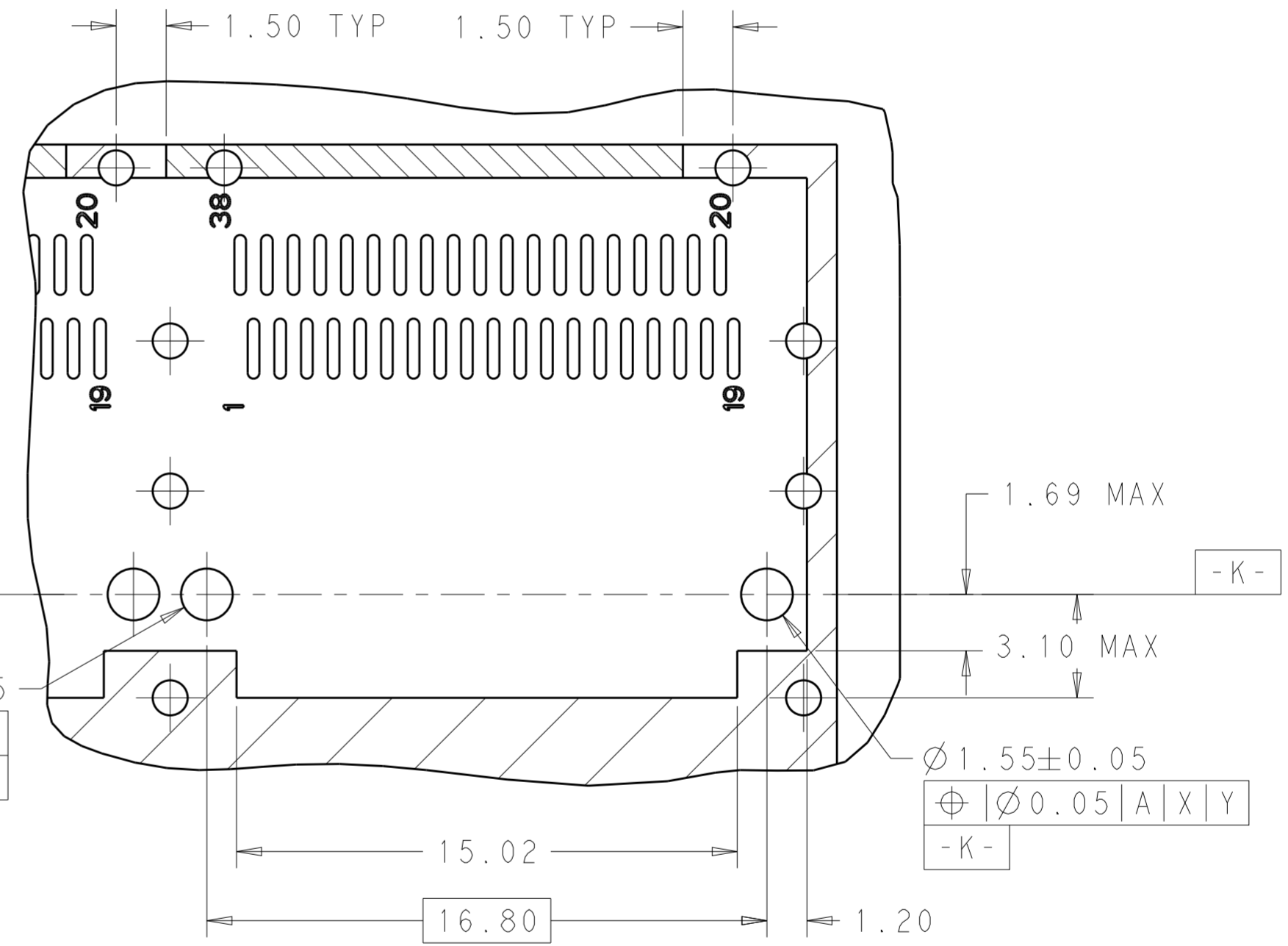

DETAIL B
SCALE 6:1

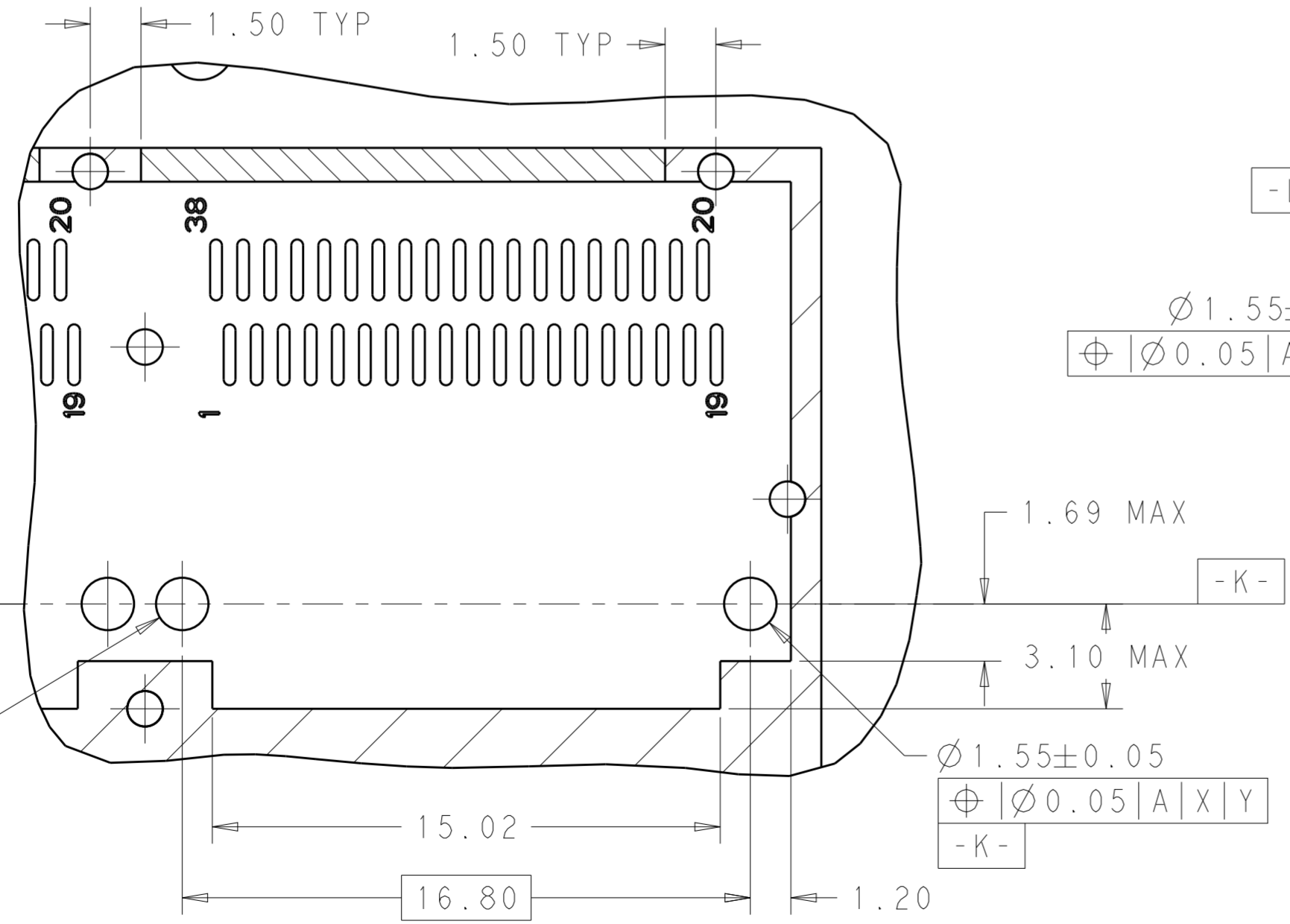

DETAIL A
SCALE 6:1

THIS DRAWING IS A CONTROLLED DOCUMENT.		DWN BING LIU 23APR2014	TE Connectivity
		CHK JASON YANG 23APR2014	
		APVD SEAN HAN 31DEC2015	NAME RECEPTACLE CAGE ASSEMBLY WITH HEAT SINKS AND LIGHT PIPES, THRU BEZEL, 1X3, QSFP28
DIMENSIONS: mm		PRODUCT SPEC 108-19428	SIZE A200779
TOLERANCES UNLESS OTHERWISE SPECIFIED: 0 PLC ± 1 PLC ±0.25 2 PLC ±0.2 3 PLC ± 4 PLC ± ANGLES ±		APPLICATION SPEC 114-32023	DRAWING NO C-2170769
MATERIAL SEE NOTES material_2		FINISH SEE NOTES finish_spec_2	RESTRICTED TO -
		WEIGHT -	SCALE 3:1 SHEET 1 OF 9 REV A1
		CUSTOMER DRAWING	

THIS DRAWING IS UNPUBLISHED. RELEASED FOR PUBLICATION 20
 © COPYRIGHT 20 BY - ALL RIGHTS RESERVED.

LOC	DIST	REVISIONS			
P	LTR	DESCRIPTION	DATE	DWN	APVD
-	-	SEE SHEET 1	-	-	-

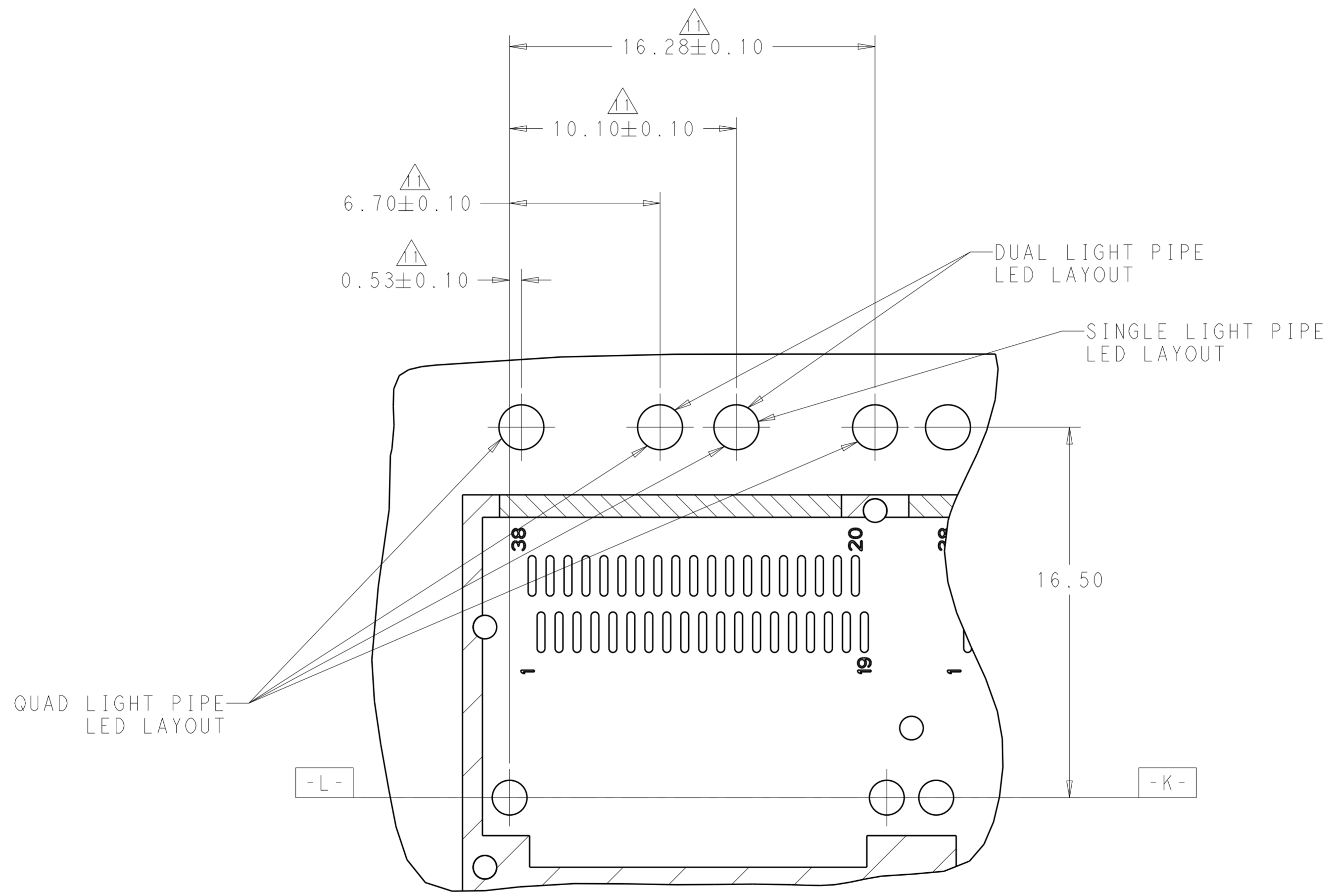

DETAIL E
SCALE 6:1

THIS DRAWING IS A CONTROLLED DOCUMENT.		DWN BING LIU 23APR2014	STE TE Connectivity
DIMENSIONS: mm		CHK JASON YANG 23APR2014	
TOLERANCES UNLESS OTHERWISE SPECIFIED:		APVD SEAN HAN 31DEC2015	NAME RECEPTACLE CAGE ASSEMBLY WITH HEAT SINKS AND LIGHT PIPES, THRU BEZEL, 1X3, QSFP28
0 PLC ± 1 PLC ±0.25 2 PLC ±0.2 3 PLC ± 4 PLC ±		PRODUCT SPEC 108-19428	SIZE A200779
MATERIAL SEE NOTES material_2		APPLICATION SPEC 114-32023	DRAWING NO C-2170769
FINISH SEE NOTES finish_spec_2		WEIGHT -	RESTRICTED TO -
CUSTOMER DRAWING		SCALE 3:1	SHEET 1 OF 9
			REV A1

单击下面可查看定价，库存，交付和生命周期等信息

[>>TE Connectivity\(泰科\)](#)