

THIS DRAWING IS UNPUBLISHED. RELEASED FOR PUBLICATION
 © COPYRIGHT - TE Connectivity Ltd. ALL RIGHTS RESERVED.

REVISIONS				
P	LTR	DESCRIPTION	DATE	APVD
B1		ECR-16-017266	01JUN2018	SR PO

NOTES:

1. ALL COLORS AND MATERIALS MADE FROM ONE TOOL.
2. SOME DIMENSIONS MAY VARY DUE TO DIFFERENT COMPOUND SHRINKAGE FACTOR.
3. MINOR FLASH ACCEPTABLE ON INSERT THREAD.
4. BLACK FINISH/NICKEL PLATING ON INSIDE THREADS REMOVED DUE TO MOLDING PROCESS PERMITTED.
5. RUBBER TO METAL BOND MUST MEET OR EXCEED THE TEAR STRENGTH OF RUBBER.
6. RUBBER OVERLAY PERMISSIBLE OVER HEX FLATS AS SHOWN IN THE DRAWING.
7. COMPONENTS MUST COMPLY WITH THE EUROPEAN DIRECTIVE 2002/95/EC ON RESTRICTION OF THE USE OF CERTAIN HAZARDOUS SUBSTANCES IN ELECTRICAL AND ELECTRONIC EQUIPMENT (ROHS DIRECTIVE).

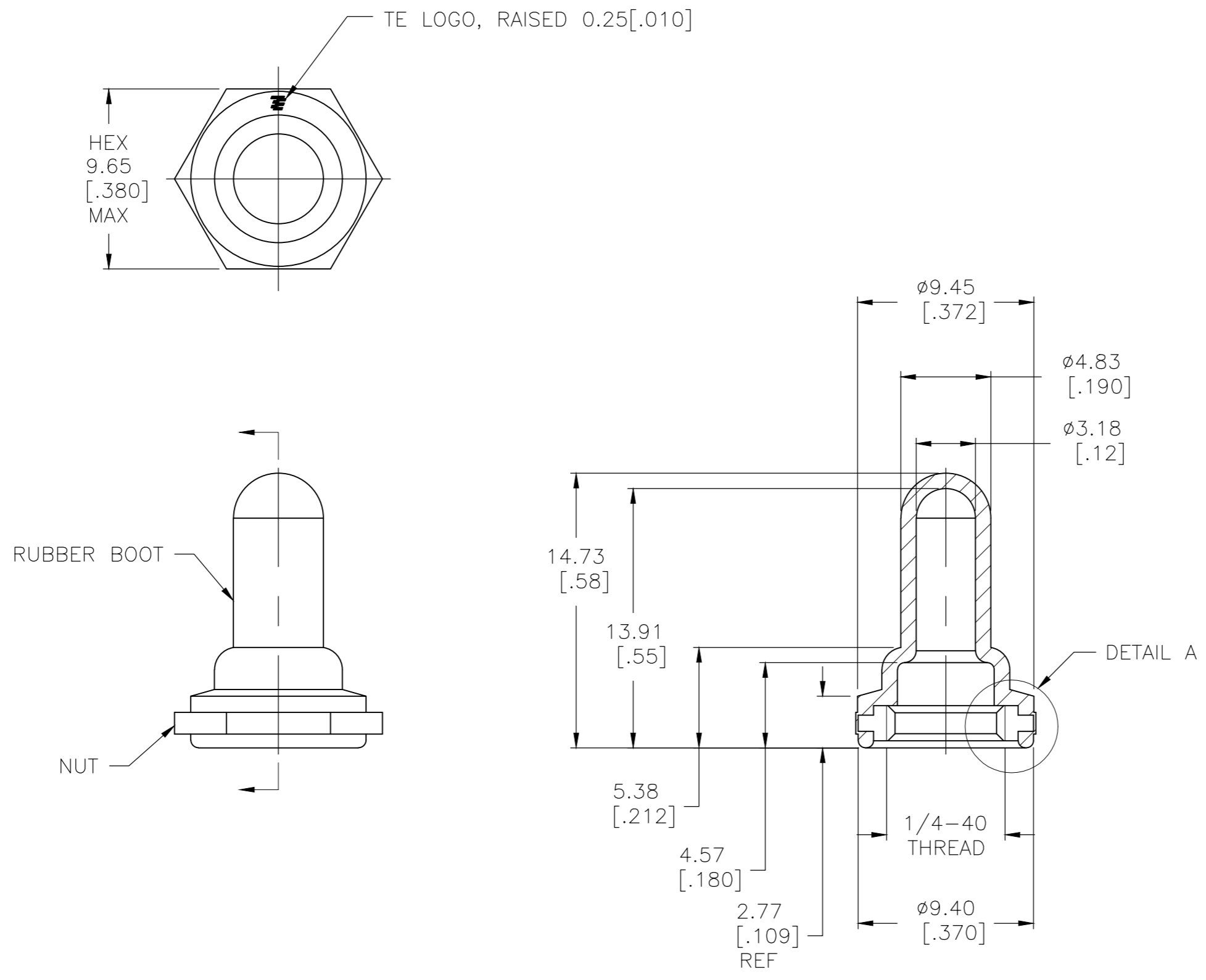

SILICONE, COLOR: GRAY	BRASS, NICKEL PLATE PER QQ-N-290	B1440804	1825612-3
SILICONE, COLOR: RED	BRASS, NICKEL PLATE PER QQ-N-290	B1440204	1825612-2
SILICONE, COLOR: BLACK	BRASS, BLACK OXIDE PER MIL-F-495	B1440004	1825612-1
RUBBER BOOT MATERIAL	HEX NUT MATERIAL	ALCO NUMBER	PART NUMBER

THIS DRAWING IS A CONTROLLED DOCUMENT.		DWN S SCHLEGEL 22JAN2008	TE TE Connectivity Ltd.	
DIMENSIONS: mm [INCHES]		CHK M WILBOURN 1/22/08		
TOLERANCES UNLESS OTHERWISE SPECIFIED:		APVD M WILBOURN 1/22/08	NAME 1/4-40 TOGGLE SWITCH BOOT SEAL	
0 PLC ± - 1 PLC ± - 2 PLC ± .01 3 PLC ± .005 4 PLC ± - ANGLES ± 5°		PRODUCT SPEC	SIZE A2	
MATERIAL		APPLICATION SPEC	CAGE CODE 00779	DRAWING NO 1825612
FINISH		WEIGHT	SCALE 4:1	SHEET 1 of 1
		CUSTOMER DRAWING	REV B1	RESTRICTED TO

单击下面可查看定价，库存，交付和生命周期等信息

[>>TE Connectivity\(泰科\)](#)