

D-18ZZC REV. B

REVISIONS		RELEASED	
REV.	DESCRIPTION	DATE	APPROVED
A	- INITIAL RELEASE	06/04/10	CB
B	07-000370 UPDATED BASE MAIN NOTE, ADDED ITEM 4 P/N, REMOVED ITEM 14 & ITEM 3 WAS -010	06/05/22	CB

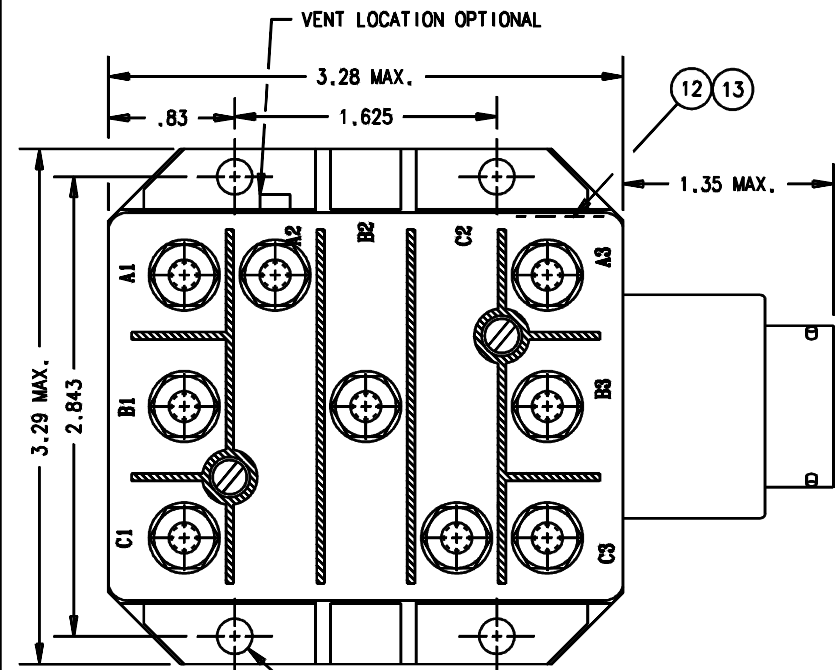

CONSTRUCTION
MAIN CONTACTS
 CONFIGURATION 3 PDT CENTER OFF
 VOLTAGE - NOMINAL 115/200 VAC 400 HZ
 CURRENT - RES. 50 AMP
AUX. CONTACTS
 CONFIGURATION 6 PDT (3 SETS EACH SIDE)
 VOLTAGE 28 VDC OR 115 VAC 400 HZ
 CURRENT - RES. 5 AMP
COIL DATA
 DUTY CYCLE CONTINUOUS
 NOM. COIL VOLTAGE 28 VDC
 PICKUP MAX. 15 VDC AT 25°C
 DROPOUT VOLTAGE 2.5 - 6.5 VDC AT 25°C
 COIL CURRENT (HOLD) .175 AMP MAX. AT 28 VDC AT 25°C
 OPERATE TIME 28 VDC 25°C TYPICAL 22 MS
 MAX. 30 MS
 RELEASE TIME 28 VDC 25°C TYPICAL 10 MS
 MAX 15 MS

ENVIRONMENTAL DATA
 AMBIENT TEMP. -55°C TO +71°C
 ALTITUDE 50,000 FT. MAX.
 SHOCK 25 G'S MAX. 6 - 9 MILLISECONDS
 VIBRATION 10 G'S SINE
 ACCELERATION 10 G'S
 LIFE ELECTRICAL 50,000 CYCLES MIN.
 LIFE MECHANICAL 100,000 CYCLES MIN.
 WEIGHT MAX. 1.5 LBS.

GASKET SEALED, VENTED

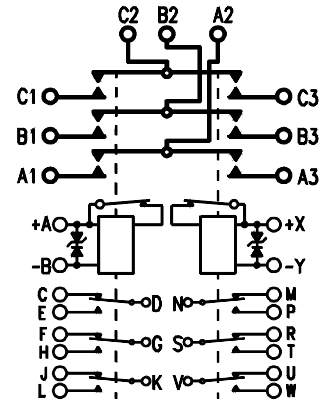

- NOTES:**
1. COIL TRANSIENT VOLTAGE LIMITED TO ± 45 VOLTS.
 2. SUITABLE FOR USE ON 50 AMP LOAD TRANSFER APPLICATIONS.
 3. THIS UNIT MEETS THE MATERIAL & WORKMANSHIP REQUIREMENTS OF MIL-R-6106.

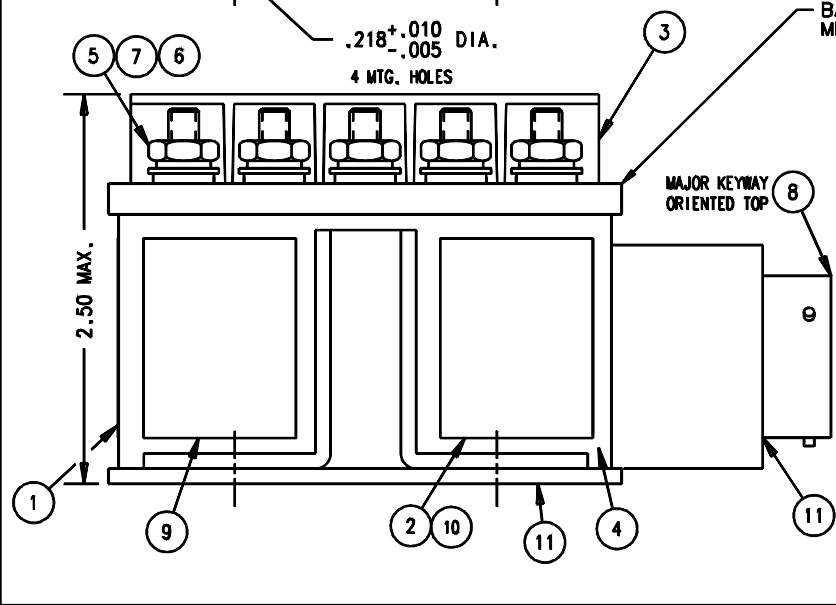

BASE MAIN MATERIAL IS G9 GLASS MELAMINE PER ASTM-D-709.

13	1	39529-024	OVERLAY			
12	1	58400-180	PLATE - FAA/PMA			
11	AR	54102-001	GLYPHTAL			
10	1	39529-037	OVERLAY			
9	1	25695-001	PLATE - WARNING			
8	1	REF.	CONNECTOR - MS3470L-1626P			
7	9	51810-054	WASHER - LOCK NO.10 SPLIT			BRONZE
6	9	51712-194	WASHER - 7/16 X 13/64 X .032 FLAT			BRONZE
5	9	50410-084	NUT - 10-32 X 3/8 X 1/8 HEX.			BRASS
4	1	42384-030	CONTACTOR ASSEMBLY - PRIMARY			
3	1	44255-020	TERMINAL SHIELD ASSY			
2	1	42778-001	PLATE - WIRING DIAGRAM			
1	1	16043-049	PLATE - NAME			

FIND NO	QTY REQD	PART OR IDENTIFYING NO	NOMENCLATURE OR DESCRIPTION	FSOM NO	DRAWING OR SPECIFICATION	MATERIAL OR NOTE
UNLESS OTHERWISE SPECIFIED DIMENSIONS ARE IN INCHES TOLERANCES ON						
2 PL DEC.		3 PL DEC.	ANGLES			
± .06		± .010	± 1°			
REF. CANADAIR			DR BY RCB 06/04/10 CHK BY CB 06/05/22 ENGR DM 06/05/22 MFG DA 06/05/22	 Hartman Division - 175 N. DIAMOND STREET WANSFIELD, OHIO 44002		
				CONTACTOR - 3PDT, CENTER-OFF 50 AMP, 400 HZ 093		
				DNG NO. D-18ZZC		
				REF TYCO P/N 1-1616957-3		
SIZE C		CODE IDENT 74063				
SCALE NONE		SHEET				

单击下面可查看定价，库存，交付和生命周期等信息

[>>TE Connectivity\(泰科\)](#)