

LOC		DIST		REVISIONS			
GP	00	REV	DATE	BY	CHKD	APPROV	
B1		REVISED PER ECO-11-005033	26MAR11	RK	HMR		

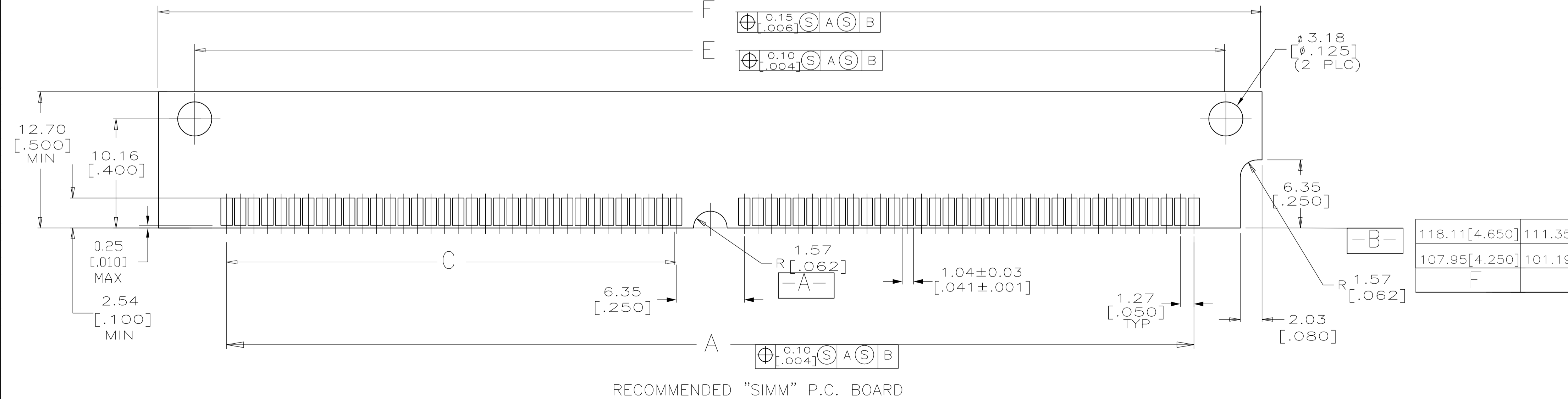

- △ HOUSING-MATERIAL : LIQUID-CRYSTAL-POLYMER, COLOR: NATURAL.
- △ CONTACT-MATERIAL : PHOS. BRONZE.
- △ LATCH-MATERIAL : BRASS, NICKEL PLATE
- △ CONTACT-PLATE: 0.00508[.000200] MIN MATTE TIN OVER 0.00127 [.000050] MIN NICKEL.
- 5. IN ADDITION TO THOSE RECOMMENDED "SMM" P.C. BOARD DIMENSIONS AND TOLERANCES SHOWN, ALL JEDEC SPECIFICATIONS APPLY AS SHOWN ON MO-116, ISSUE A.
- 6. RECOMMENDED MATING S.I.M.M. TAB METALLURGY: BASE METAL-COPPER. PLATING TO BE 0.00762[.000300] MIN TIN/LEAD OVER 0.00127[.000050] MIN NICKEL.
- △ DATE CODE: (YEAR WEEK) XXXX FORMAT, LOCATED APPROXIMATELY AS SHOWN ON OPPOSITE SIDE.

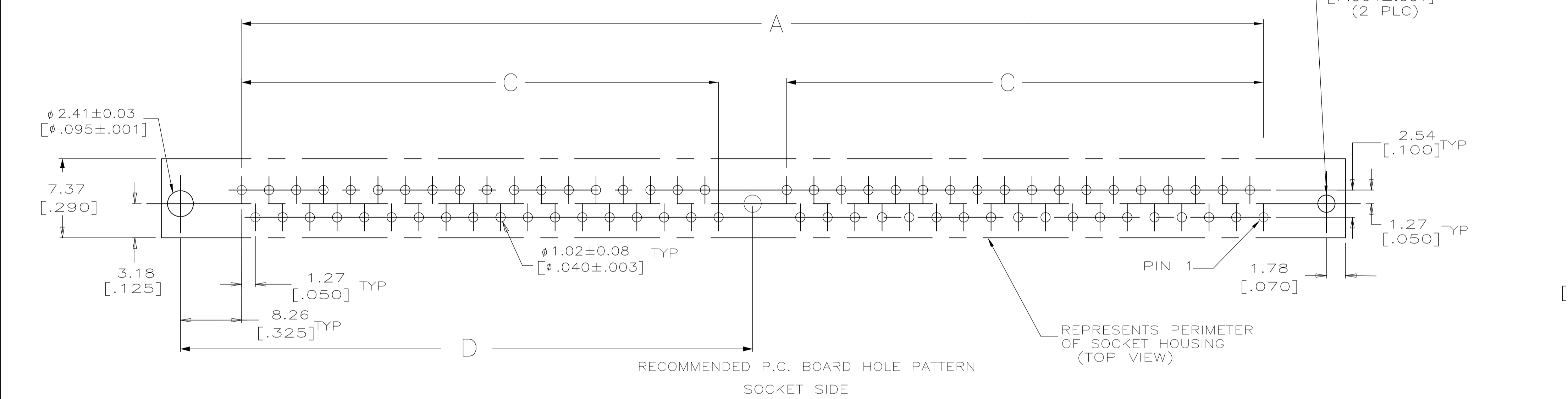
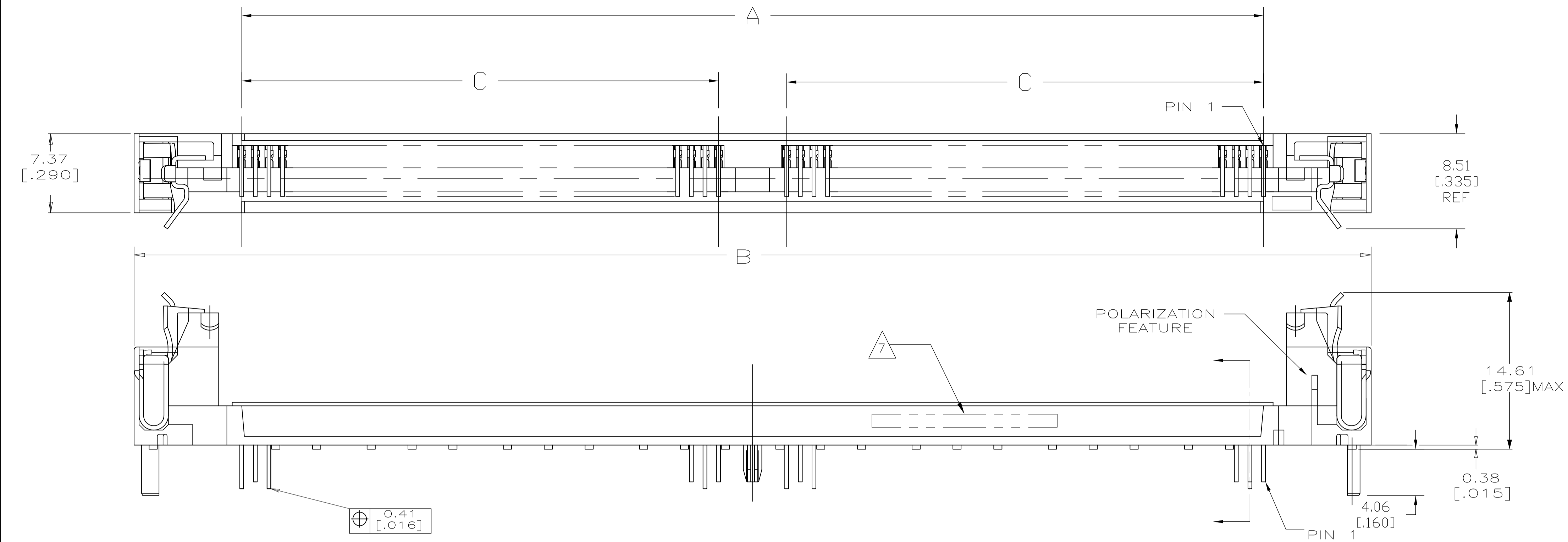
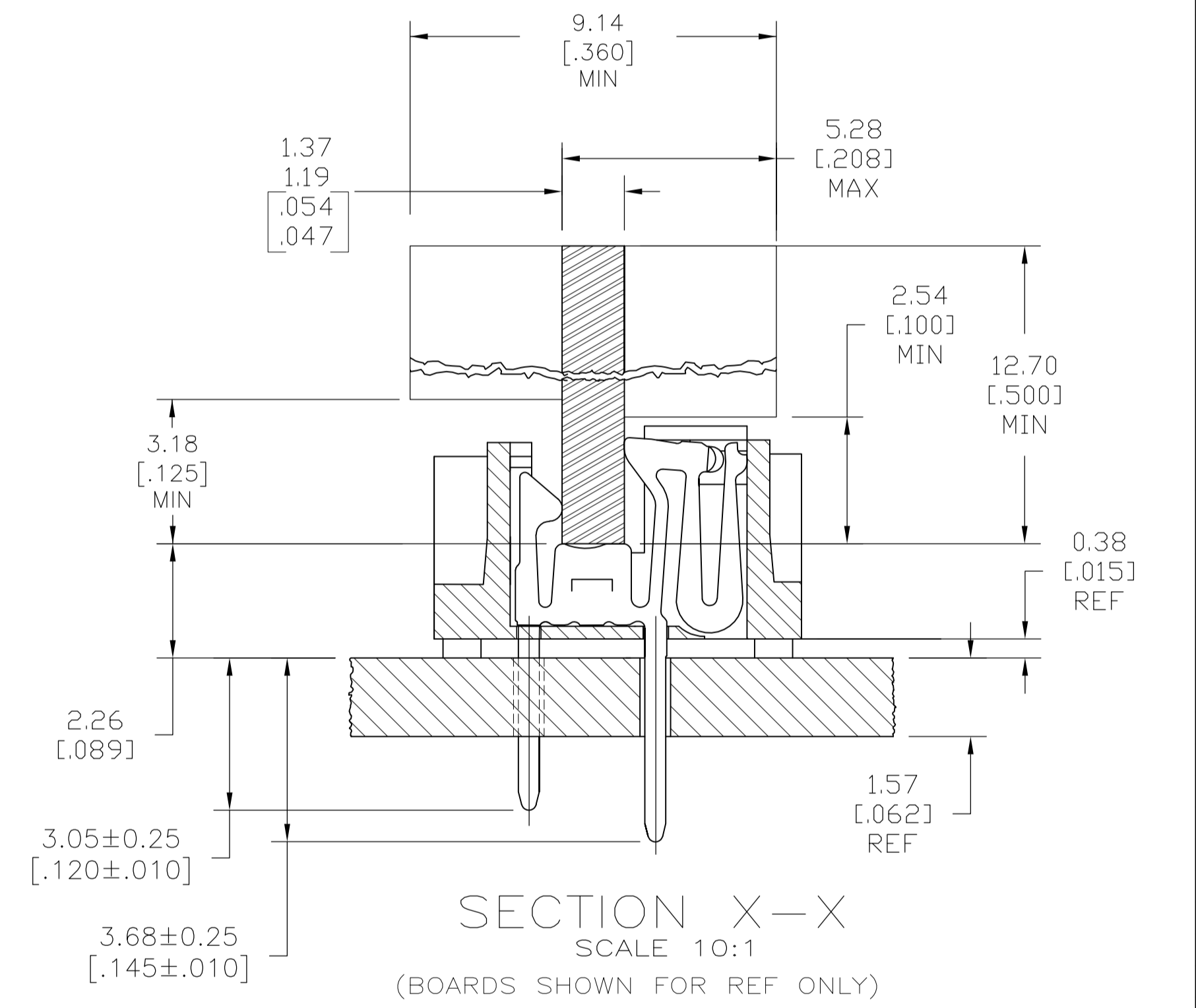

118.11[4.650]	111.35[4.384]	60.96[2.400]	49.53[1.950]	125.73[4.950]	105.41[4.150]	80	5822021-5
107.95[4.250]	101.19[3.984]	55.88[2.200]	44.45[1.750]	115.57[4.550]	95.25[3.750]	72	5822021-4
F	E	D	C	B	A	NO OF POSN	PART NO

THIS DRAWING IS A CONTROLLED DOCUMENT.		DIN S. WAITMAN SJANOS		TE Connectivity	
DIMENSIONS: mm [INCHES]		CIR: M. YFOMANS SJANOS		NAME	
TOLERANCES UNLESS OTHERWISE SPECIFIED:		APPRO: M. YFOMANS SJANOS		CONNECTOR, MICRO-EDGE, .050, VERTICAL, TIN PLATE, METAL LATCH	
0 PLC ± -	1 PLC ± -	2 PLC ± 0.13[.005]	3 PLC ± -	4 PLC ± -	ANGLES ± -
MATERIAL		FINISH		SIZE	CAGE CODE
CUSTOMER DRAWING		SCALE 4:1		DRAWING NO	SHEET 1 OF 1
		WEIGHT		00779	5822021
		RESTRICTED TO		REV B1	

单击下面可查看定价，库存，交付和生命周期等信息

[>>TE Connectivity\(泰科\)](#)