

LOC		DIST		REVISIONS			
P	LTR	DESCRIPTION	DATE	DMN	APVD		
B		REVISED PER ECO-08-007327		OBAPROB	BM	WM	

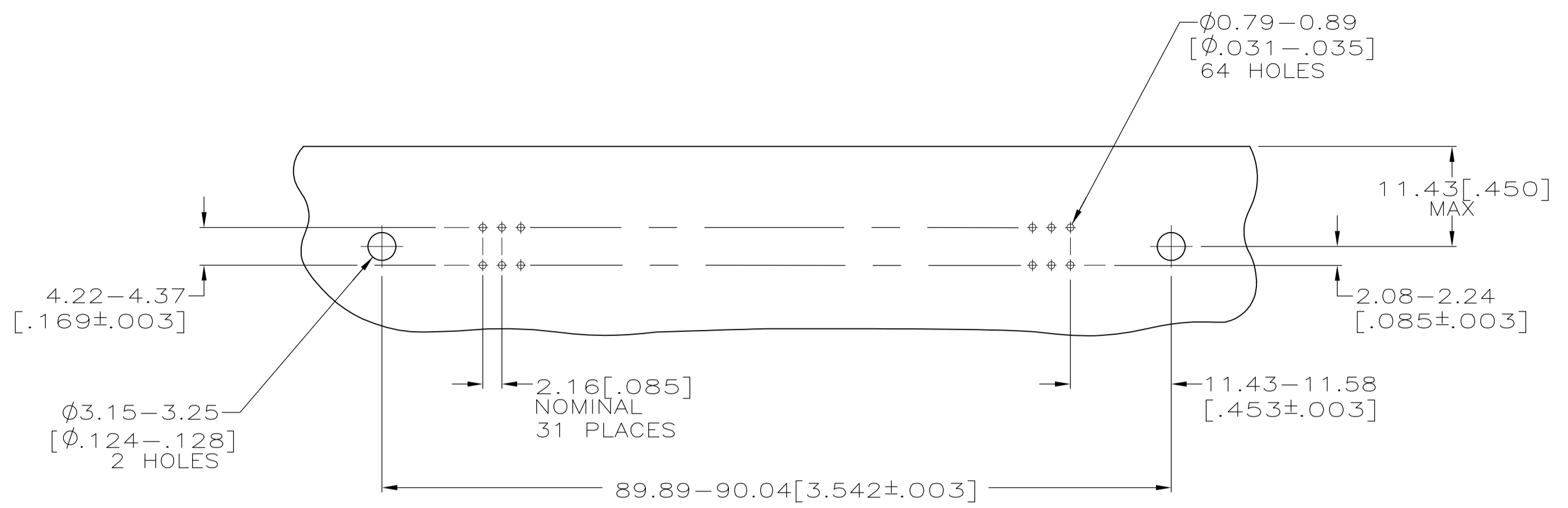

SUGGESTED PRINTED CIRCUIT BOARD MOUNTING DIMENSIONS SCALE 2:1

- 1 MATERIAL: HOUSING, BRACKET, PLATE AND COMB - THERMOPLASTIC, BLACK, 94V-0 RATED. TERMINALS - HIGH STRENGTH COPPER ALLOY PLATED WITH EITHER 0.76 μ m [.000030] MIN GOLD PLATE OR GOLD FLASH OVER PALLADIUM NICKEL PLATE, 0.76 μ m [.000030] MIN TOTAL ON MATING SURFACE. 3.05 μ m [.000120] MIN TIN PLATE ON TAILS. ALL OVER 1.27 μ m [.000050] MIN NICKEL UNDERPLATE OVER ENTIRE TERMINAL.
- 2 TERMINAL SUPPORT PLATE CLEARANCE FOR TERMINAL STRAIN RELIEF AND FLUX REMOVAL.
- 3 MAXIMUM PANEL THICKNESS: 1.57 [.062].
- 4 TERMINAL 1 IS LOCATED IN THIS ROW FOR STANDARD ORIENTATION, 5552745-1 AND -5.
- 5 DETAIL "A" IS VIEWED FROM MATING SIDE OF PLUG ASSEMBLY.
- 6 FOR USE WITH A NO.4 BT TYPE SELF-TAPPING SCREW.
- 7. IF TERMINALS DO NOT EXTEND BELOW COMB, THEN COMB SHOULD BE PARTIALLY RETRACTED BEFORE INSERTING CONNECTOR INTO PRINTED CIRCUIT BOARD.

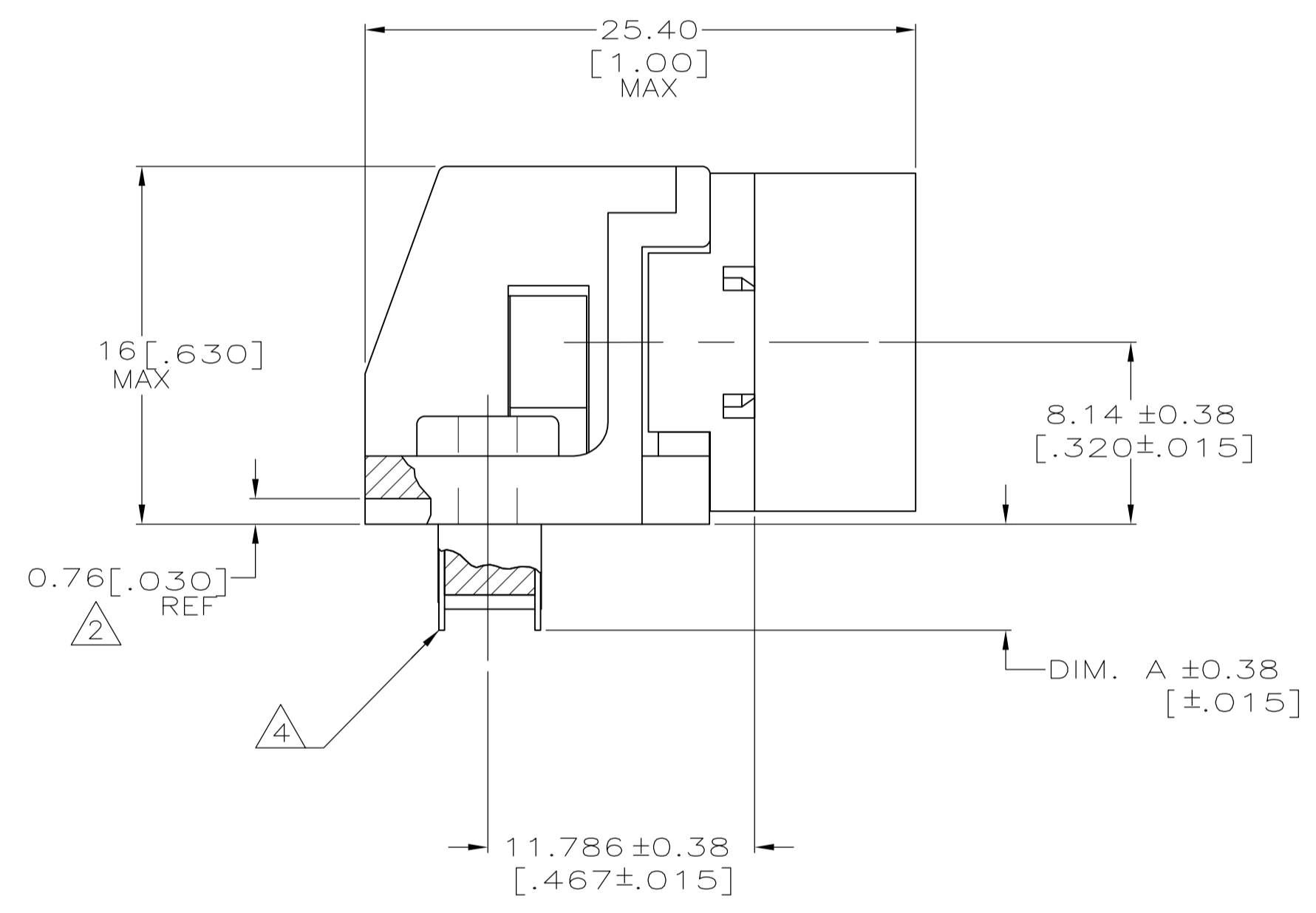
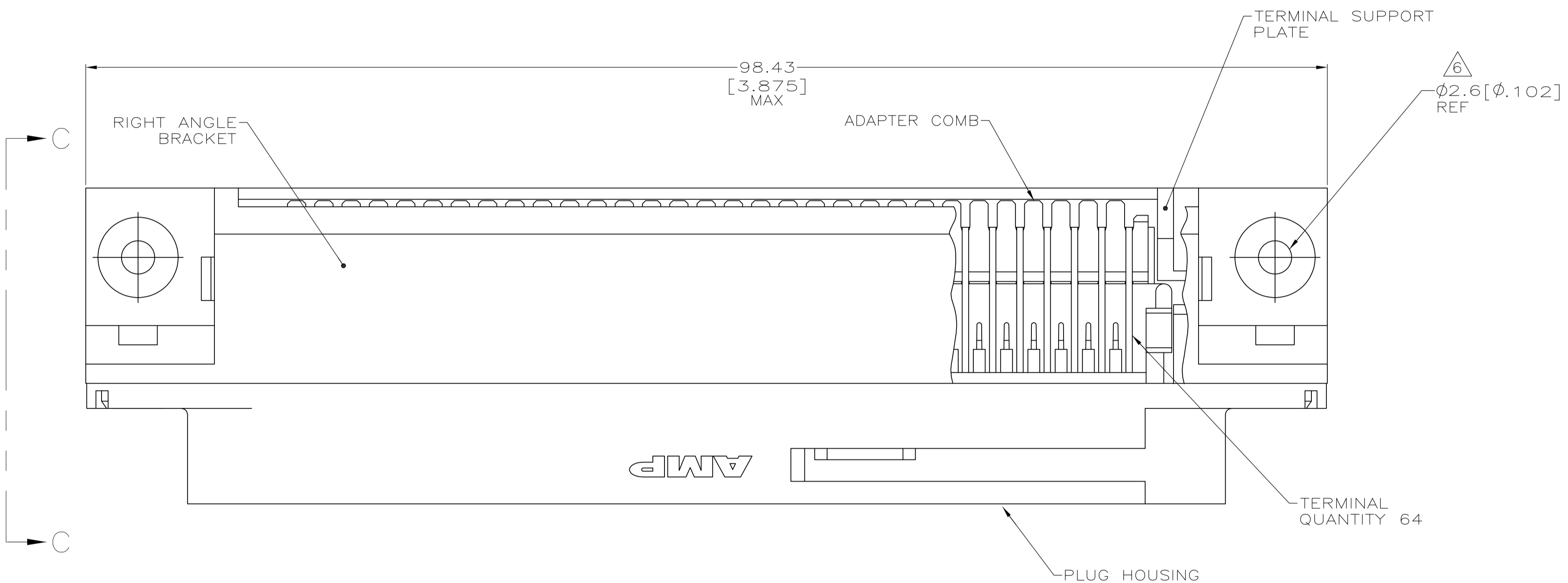

VIEW C-C ROTATED 90° CCW

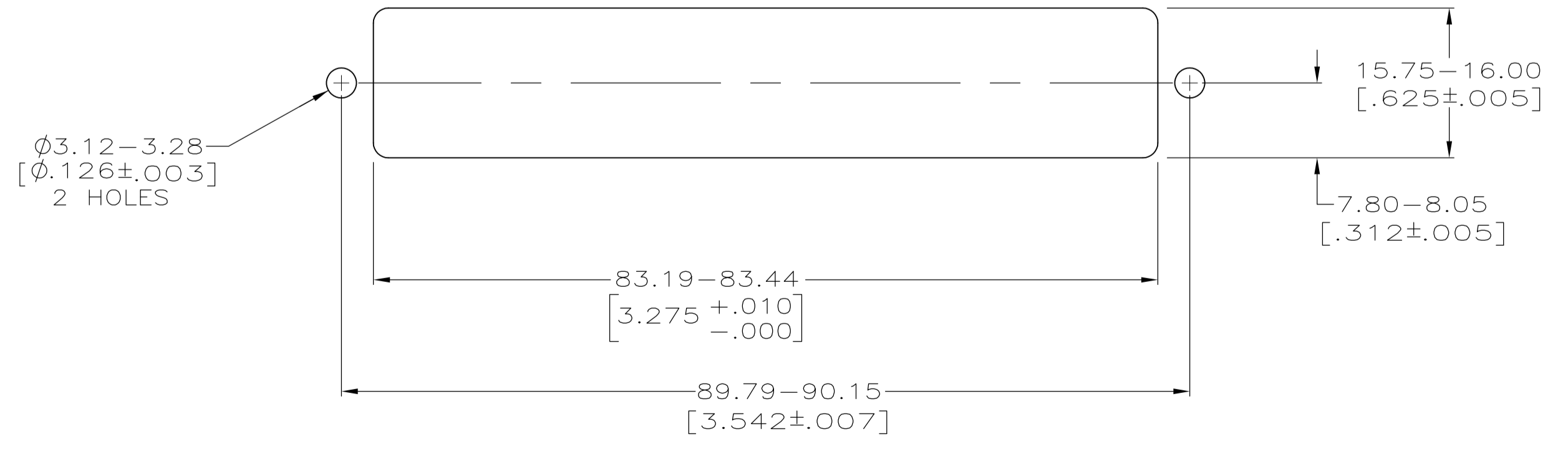

SUGGESTED REAR PANEL MOUNTING CUTOUT DIMENSIONS SCALE 2:1

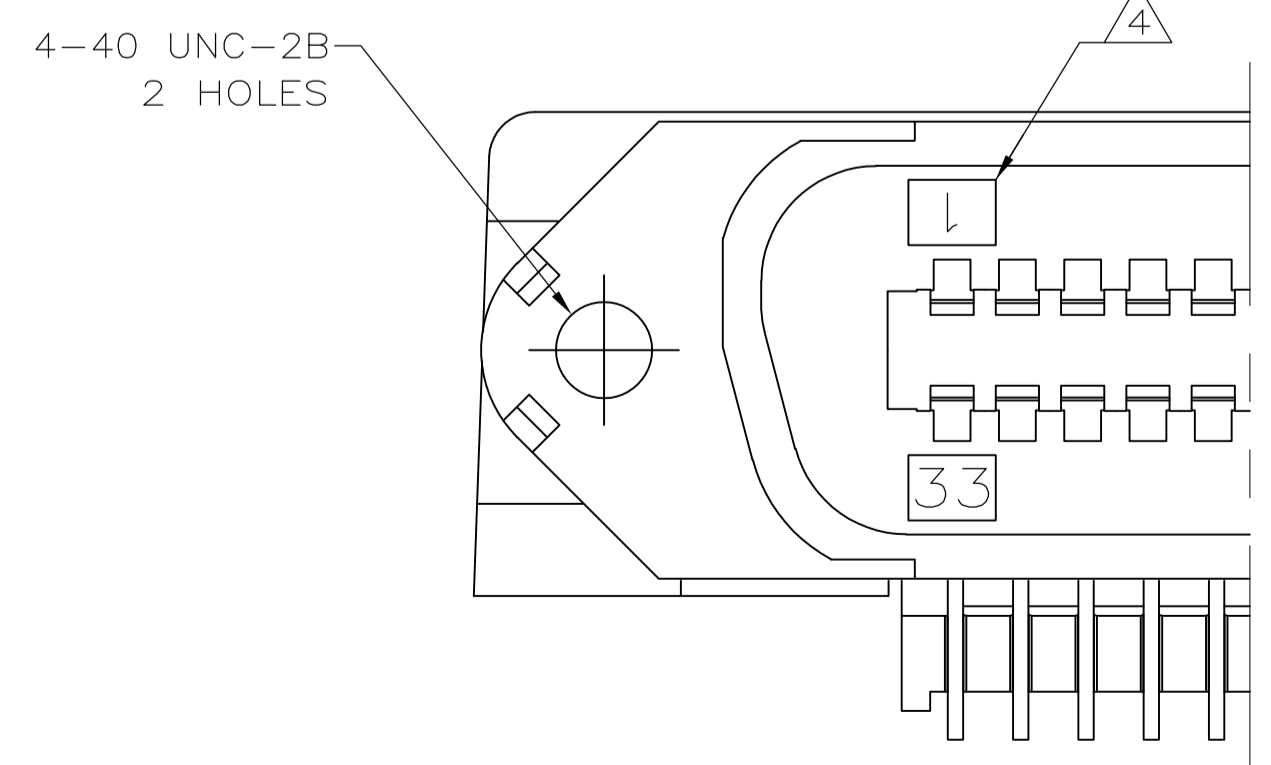

DIM. A	TYPE OF MOUNTING	DESCRIPTION	PART NUMBER
2.54 [.100]	SELF-TAPPING	SEE DETAIL A	5552745-5
4.75 [.187]	SELF-TAPPING	SEE DETAIL A	5552745-1

THIS DRAWING IS A CONTROLLED DOCUMENT.		DIN B MCMASTER 16AUG05		Tyco Electronics Corporation Harrisburg, PA 17105-3608	
DIMENSIONS: mm [INCHES]		TOLERANCES UNLESS OTHERWISE SPECIFIED:		NAME: PLUG ASSEMBLY, 64 POSITION, RIGHT ANGLE, SELF-TAPPING, CHAMP-LOK	
0 PLC	\pm -	APVD	W. WALSLEY 16AUG05	SIZE	A1
1 PLC	\pm -	APPLICATION SPEC		CAGE CODE	00779
2 PLC	\pm -			DRAWING NO	5552745
3 PLC	± 0.13 [.005]			RESTRICTED TO	
4 PLC	\pm -			WEIGHT	
ANGLES	\pm -			CUSTOMER DRAWING	
MATERIAL		FINISH		SCALE 4:1 SHEET 1 OF 1 REV B	

单击下面可查看定价，库存，交付和生命周期等信息

[>>TE Connectivity\(泰科\)](#)