

LOC	DIST	REVISIONS					
AI	00	P	LTR	DESCRIPTION	DATE	OWN	APVD
		A		INITIAL RELEASE	13MAY2022	RRD	CZ

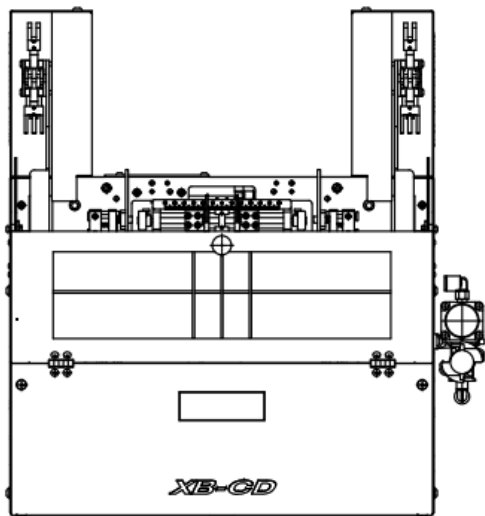

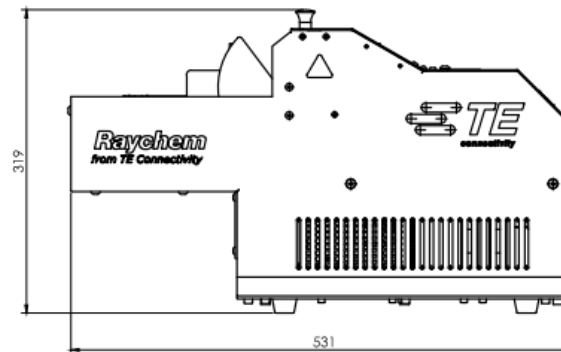
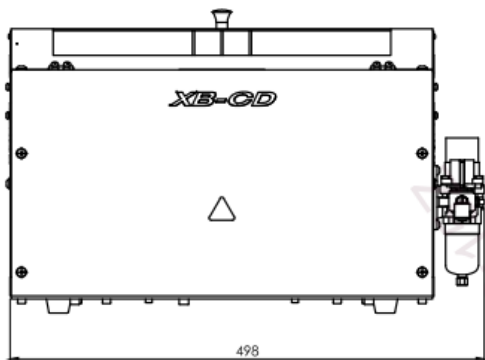

<b>THIS DRAWING IS A CONTROLLED DOCUMENT.</b>		OWN RAKESH R D 12MAY2022	
DIMENSIONS: mm		CHK C. ZHU 12MAY2022	
TOLERANCES UNLESS OTHERWISE SPECIFIED: 0 PLC ± 1 PLC ± 2 PLC ± 3 PLC ± 4 PLC ± ANGLES ±		APVD C. ZHU 12MAY2022	NAME CENTERING DEVICE, XB BELT HEATER
MATERIAL		FINISH	PRODUCT SPEC
MATERIAL		FINISH	APPLICATION SPEC
MATERIAL		FINISH	SIZE A2
MATERIAL		FINISH	CAGE CODE 00779
MATERIAL		FINISH	DRAWING NO. 2375330-1
MATERIAL		FINISH	RESTRICTED TO A
MATERIAL		FINISH	SCALE 1:1
MATERIAL		FINISH	SHEET 1 of 2
MATERIAL		FINISH	REV A
MATERIAL		FINISH	CUSTOMER DRAWING

D  
C  
B  
A

## Recommend Spart List

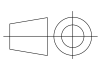
ITEM NO	DESCRIPTION	PART NO	QTY
1	STOP PLATE	1-2375332-7	2
2	LINEAR GUIDE RAIL	1-2375334-1	2
3	DEEP GROOVE BALL BEARING	1-2375334-6	2
4	SYNCHRONOUS BELT	1-2375334-8	1
5	D-SUB CONNECTOR	2-2375334-2	1
6	MAGNETIC BUCKLE WITH SWITCH	2-2375334-3	1
7	SOLENOID VALVE	2-2375334-4	2
8	BENT GAS CONNECTOR	2-2375334-7	3
9	STEPPR MOTOR	2375334-1	2
10	MOTOR CONTROLLER	2375334-2	2
11	3PIN CONNECTOR (MALE)	2375334-4	1
12	POWER SUPPLY	2375334-5	1
13	MACHINED COMPONENTS	3-2375332-8	1
14	SHEET METAL PARTS	3-2375332-9	2
15	DRAG CHAIN	3-2375334-2	2
16	PHOTOELECTRIC SWITCH	3-2375334-3	3
17	EMBOSSING KNOB	3-2375334-6	2
18	LOCATING PIN	3-2375334-7	2
19	LOCATING PIN	3-2375334-8	2
20	GOVERNOR VALVE	3-2375334-9	2
21	DRAG SPRING	4-2375334-1	1
22	COMPRESSION SPRING	4-2375334-4	8
23	ADJUSTING SCREW	4-2375334-5	1
24	CYLINDER	4-2375334-6	2
25	HINGE	5-2375334-1	2
26	MANUAL VALVE	5-2375334-3	1
27	A PARTITION	5-2375334-4	1
28	PRESSURE REGULATING VALVE	5-2375334-5	1
29	BENT GAS CONNECTOR	5-2375334-6	2
30	MAGNETIC BUCKLE	5-2375334-8	2

P	LTR	REVISION RECORD	DATE	DWN	APVD	PRINTED	DWN	CHK	APVD
-			-	-	-		12MAY2022	12MAY2022	12MAY2022
-			-	-	-	RAKESH R D		C, ZHU	C, ZHU
-			-	-	-	WEIGHT	DIMENSION (mm)	MATERIAL	HT TR
-			-	-	-	SEE SHEET 1	SEE SHEET 1	SEE SHEET 1	SEE SHEET 1
-		SEE SHEET 1	-	-	-	 TOLERANCES UNLESS OTHERWISE SPECIFIED SEE SHEET 1	 <b>TE Connectivity</b> <b>SPARE AND WEAR PARTS LIST</b>		
THIS DRAWING IS A CONTROLLED DOCUMENT FOR TYCO ELECTRONICS CORPORATION. IT IS SUBJECT TO CHANGE AND THE CONTROLLING ENGINEERING ORGANIZATION SHOULD BE CONTACTED FOR THE LATEST REVISION.  DIESES ZEICHNUNGSDOKUMENT WIRD DURCH TYCO ELECTRONICS CORPORATION KONTROLLIERT. ÄNDERUNGEN DIE DEM TECHNISCHEN FORTSCHRITT DIENEN, SIND VORBEHALTEN. DEN JEWEILS LETZTGÜLTIGEN ÄNDERUNGSSTAND ERFAHREN SIE AUF ANFRAGE							NAME CENTERING DEVICE, XB BELT HEATER	RESTRICTED TO -	
SCALE		SIZE		DRAWING NO		SHEET		REV	
SEE SHEET 1		A4		C-2375330-1		2/2		A	

单击下面可查看定价，库存，交付和生命周期等信息

[>>TE Connectivity\(泰科\)](#)