

NUMBER 66143 SHT. 1 OF 1

© 1962 BY AMP INCORPORATED. ALL RIGHTS RESERVED. AMP PRODUCTS COVERED BY PATENTS AND/OR PATENTS PENDING.

REVISIONS						
SYM	ZONE	DESCRIPTION		DATE	APPROVAL	
H		REVISED SHT. 1 & 2 V-906	m.s.	2-11-5	D. H.	
J		REVISED SHT. 1 & 2 W-191, W-239	m.s.	5-3-5	R. M.	
J-1		REVISED SHT. 1 & 2	1792	m.s.	5-2-68	D.H.
J-2		REVISED SHT. 1 & 2	1827	m.s.	6-19-69	m.s. J.H.
K		REVISED SHT. 1 & 2	1910	m.s.	9-20-68	D.H.
K-1		ADD -6 & -7	2148	m.s.	7-13-69	D.H.
K-2		REVISED	3670	m.s.	10-24-72	D.R.
L		REVISED	6124	m.s.	7-10-79	
M		REVISED	6198	m.s.	8-14-79	
N		REVISED PER AD1322			7-2-86	CP

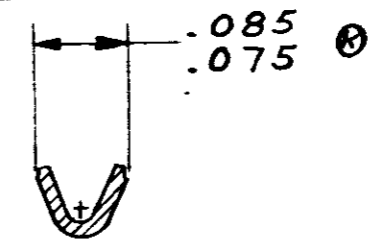
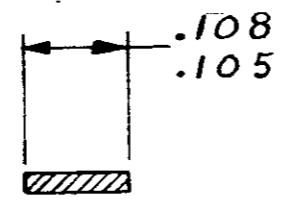
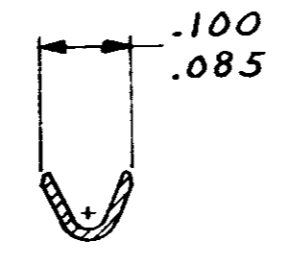
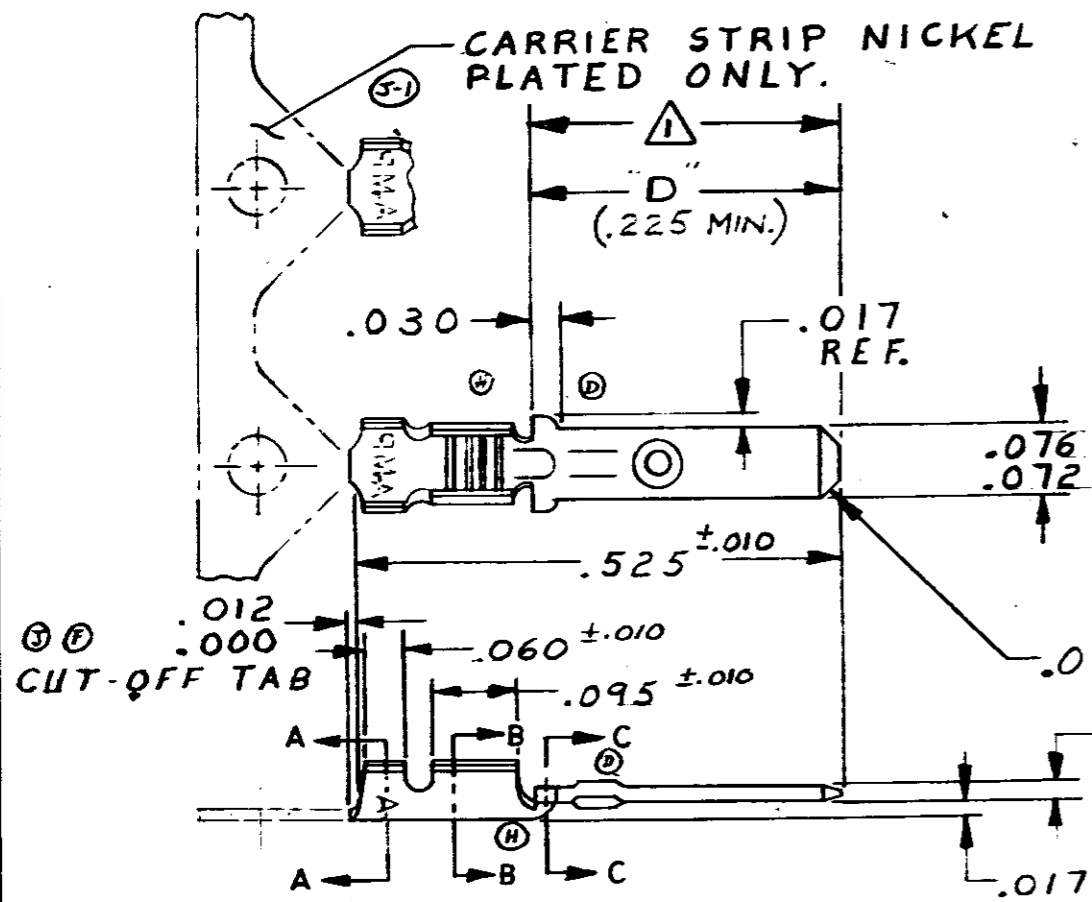

WIRE RANGE : 26-22
 INSULATION RANGE : .053 MAX.
 Δ GOLD PLATING IN TAB AREA ONLY, REMAINDER OF CONTACT NICKEL PLATED.

66143-3	66168-3	66355-3	.000015 AU./ .000050 NI.
66143-2	66168-2	66355-2	.000030 AU./ .000050 NI.

QTY REQD	PART OR IDENTIFYING NO.	NOMENCLATURE OR DESCRIPTION	STRIP W/N STD. REELING R-L FEED	L.P. NO.	L-R FEED FOR MINI-APPL.	FINISH			
LIST OF MATERIALS OR PARTS LIST									
UNLESS OTHERWISE SPECIFIED DIMENSIONS ARE IN INCHES TOLERANCES ON FRACTIONS DECIMALS ANGLES \pm # \pm .005 \pm 1° 0'			SIGNATURE		DATE	 AMP INCORPORATED HARRISBURG, PENNSYLVANIA AMP-TAB MALE CONTACT			
MATERIAL			DR R.L. MILLER		11-20-62				
HEAT TREAT			CHK RUNKLE		11-20-62				
FINISH			DSGN ENGR R. SHOWMAN		11-20-62				
SEE TABLE			APPD G. REIDER		11-20-62				
AMP INFO			DSGN APPD		CODE IDENT NO	SIZE	NUMBER		
LOC PRINT EST AD39N			OTHER APPD		00779	B	66143		
					SCALE 5-1	WT	CALC	ACTUAL	SHEET 1 OF 1

单击下面可查看定价，库存，交付和生命周期等信息

[>>TE Connectivity\(泰科\)](#)