

LOC J	DIST F	REVISIONS 変更			DATE	DWN	APVD
P	LTR	DESCRIPTION			25APR08	T.T	T.F
	B	REVISED ECR-08-002095					

-1: 本図
-1: AS SHOWN

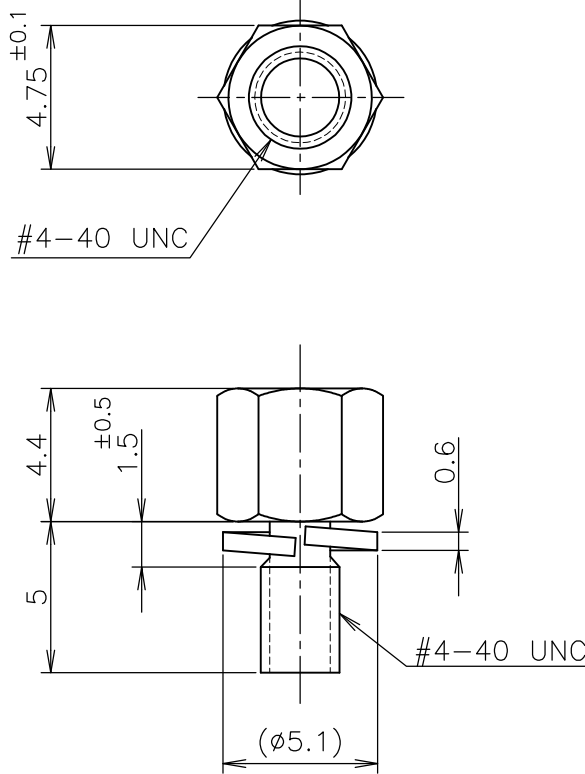

- 1 材料: 鋼
- 2 仕上げ: ニッケルめっき
- 3 スクリューロック取付け時の締め付けトルク: 49N-cm (5kgf-cm) 以下

- 1 MATERIAL: CARBON STEEL
- 2 FINISH: NICKEL PL.
- 3 SCREWLOCK TORQUE WHEN MOUNTED: 49N-cm (5kgf-cm) MAX.

GENERAL TOLERANCE
一般公差

10 ≥ ±0.2
30 ≥ >10: ±0.25
100 ≥ >30: ±0.3
ANGLES: ±3°

RELEASED FOR PUBLICATION
JUL , 1994.

ALL RIGHTS RESERVED.

ALL RIGHTS RESERVED.

BY TYCO ELECTRONICS CORPORATION.

© COPYRIGHT 1994

THIS DRAWING IS UNPUBLISHED.

DIMENSIONS: 単位: 耗 mm	DWN T.KAWAMAE	29JUL94	MATERIAL 材料	FINISH 仕上
	CHK Y.FUJIURA	29JUL94	Tyco Electronics Corporation Kawasaki, Japan	
TOLERANCES UNLESS OTHERWISE SPECIFIED: 一般公差	APVD Y.FUJIURA	29JUL94		
	0 PLC ±	PRODUCT SPEC 製品規格	SIZE A4	CAGE CODE 00779
1 PLC ±	APPLICATION SPEC 取付適用規格	WEIGHT	RESTRICTED TO	
2 PLC ±			CUSTOMER DRAWING	
3 PLC ±			SCALE 尺度 4:1	SHEET 1 OF 1
4 PLC ±				REV B
ANGLES ±				

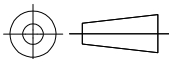

单击下面可查看定价，库存，交付和生命周期等信息

[>>TE Connectivity\(泰科\)](#)