

P	LTR	DESCRIPTION	DATE	DWN	APVD
	L	REV PER ECR 09-013993	19JUN09	JR	TM
	L1	REVISED PER ECO-16-017419	14MAR2017	RS	DR
	M	REVISED PER ECO-19-016812	20JUL2020	SG	DR

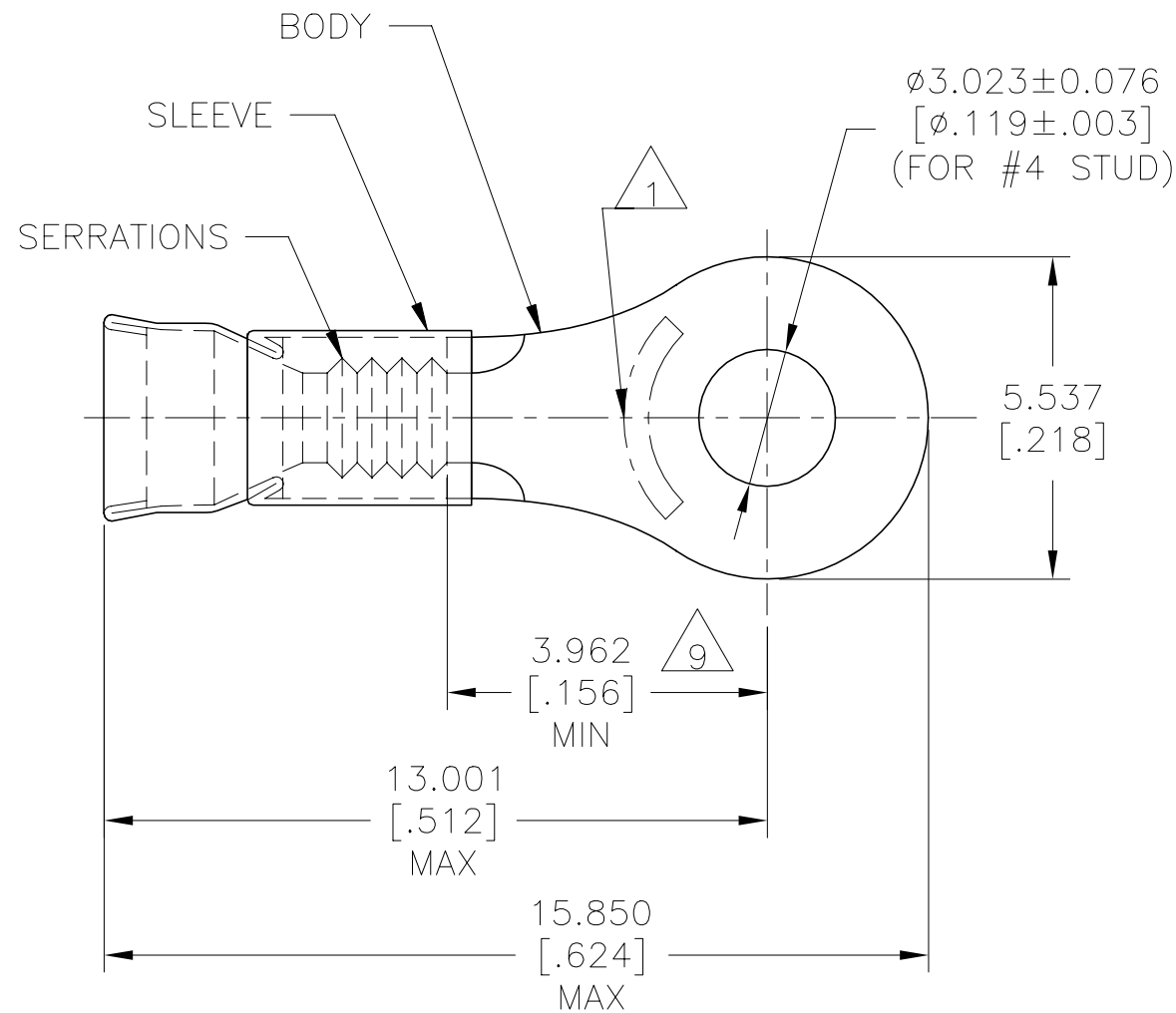

- 1 STAMP AMP 22-18\* APPROX AS SHOWN  
22-16 TERMINALS ARE STAMPED 22-18 IN  
ACCORDANCE WITH MILITARY SPEC SAE AS7928  
COMMERCIAL WIRE RANGE IS 22-16.
- 2 WIRE INSUL DIA,  $\phi 2.667 - 3.556$  [ $\phi .105 - .140$ ].
- 3 BODY MATL THK,  $0.787 \pm 0.051$  [ $.031 \pm .002$ ].
- 4 BODY, NICKEL-PLATE PER SAE AMS QQ-N-290.  
0.076 [ $.000300$ ] MIN EXT THK.
- 5 FINISH:  
BODY: GOLD PLATE  $0.00127$  [ $.000050$ ] MIN EXT THK PER  
ASTM B488, TYPE I, CODE C OVER NICKEL PLATE  
0.00127 [ $.000050$ ] MIN EXT THK PER SAE AMS QQ-N-290
- 6 MATERIAL: BODY - CU PER ASTM B152  
SLEEVE - NI SILVER PER ASTM B122.
- 7 MATERIAL: BODY & SLEEVE,  
COPPER PER ASTM B152
- 8 FINISH:  
BODY & SLEEVE: GOLD PLATE  $0.00127$  [ $.000050$ ] MIN EXT THK PER  
ASTM B488, TYPE I, CODE C OVER NICKEL PLATE  
0.00127 [ $.000050$ ] MIN EXT THK PER SAE AMS QQ-N-290
- 9 APPLIES FROM EDGE OF METAL WIRE BARREL TO CENTER OF  
STUD HOLE

260°C [500F]	8	7	1000	LOOSE PIECE	322363-2
260°C [500F]	5	6	1000	LOOSE PIECE	322363-1
343°C [649F]	4	6	1000	LOOSE PIECE	322363
MAX TEMP	FINISH	MATERIAL	QTY	PACKAGE TYPE	PART NO

<b>AMP INCORPORATED CUSTOMER SERVICE SYSTEMS</b>		MAX RECOMMENDED OPERATING TEMPERATURE: SEE CHART	THIS DRAWING IS A CONTROLLED DOCUMENT.		DWN L OLMEDA 10OCT94	<b>STE</b> TE Connectivity				
FOR ADDITIONAL PRODUCT INFORMATION OR COPIES OF DRAWINGS AND TECHNICAL DOCUMENTS	PRODUCT INFORMATION CENTER 1-800-522-6752	VOLTAGE RATING: -	DIMENSIONS: mm [INCHES]	TOLERANCES UNLESS OTHERWISE SPECIFIED:	CHK M ELLIS 10OCT94	NAME				
FOR APPLICATION TOOLING INFORMATION	TOOLING ASSISTANCE CENTER 1-800-722-1111	CIRCULAR MIL AREA: 0.26-1.65mm <sup>2</sup> [509-3260] STRANDED		0 PLC ± - 1 PLC ± - 2 PLC ± - 3 PLC ± 0.127[.005] 4 PLC ± - ANGLES ± -	APVD S BORTNER 10OCT94	TERMINAL, RING TONGUE, STRATOTHERM, DIAMOND GRIP, WIRE SIZE: 22-16 AWG				
FOR ORDER ENTRY	1-800-526-5142	THIS DRAWING IS A CONTROLLED DOCUMENT FOR AMP INCORPORATED. IT IS SUBJECT TO CHANGE AND THE CONTROLLING ENGINEERING ORGANIZATION SHOULD BE CONTACTED FOR THE LATEST REVISION.	MATERIAL SEE TABLE	FINISH SEE TABLE	PRODUCT SPEC -	APPLICATION SPEC 114-2162	SIZE A3	CAGE CODE 00779	DRAWING NO C-322363	RESTRICTED TO -
					CUSTOMER DRAWING		SCALE 6:1	SHEET 1 OF 1	REV M	

单击下面可查看定价，库存，交付和生命周期等信息

[>>TE Connectivity\(泰科\)](#)