

THIS DRAWING IS UNPUBLISHED. RELEASED FOR PUBLICATION  
 © COPYRIGHT - By - ALL RIGHTS RESERVED.

| LOC | DIST | REVISIONS |     |                           |         |     |      |
|-----|------|-----------|-----|---------------------------|---------|-----|------|
| G   | 14   | P         | LTR | DESCRIPTION               | DATE    | DWN | APVD |
|     |      |           | K2  | REVISED PER ECO-11-004820 | 11MAR11 | RK  | HMR  |

|                                |                                |                                |
|--------------------------------|--------------------------------|--------------------------------|
| <b>AMP</b><br>WIRE RANGE       | Listed<br>FILE E13288          | LR7189<br>Certified            |
| 22-16 AWG<br>SOLID OR STRANDED | 22-16 AWG<br>SOLID OR STRANDED | 22-16 AWG<br>SOLID OR STRANDED |

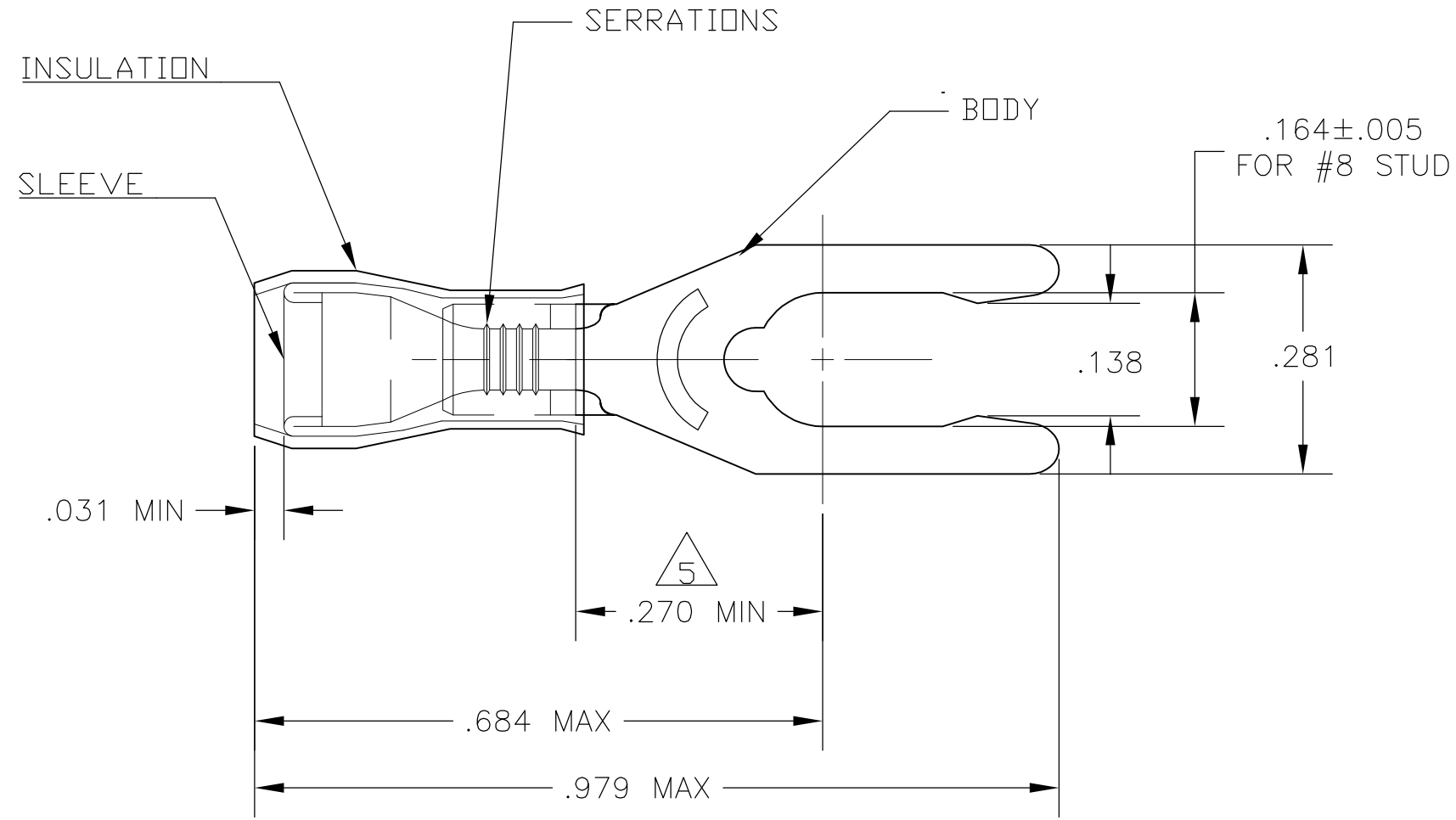

- 1 STAMP AMP 22-18\* APPROX AS SHOWN  
22-16 TERMINALS ARE STAMPED 22-18 IN ACCORDANCE WITH MILITARY SPEC MIL-T-7928  
COMMERCIAL WIRE RANGE IS 22-16
- 2 WIRE INSULATION DIA: .080-.125
- 3 TONGUE MATERIAL THK: .031±.002
- 4 MATERIAL: BODY - PHOS BRONZE PER ASTM B103  
TIN PLATE PER ASTM B545  
SLEEVE - CU PER ASTM B152  
TIN PLATE PER ASTM B545  
INSULATION - NYLON, COLOR - SEE TABLE
- 5 APPLIES FROM THE METAL EDGE OF BARREL TO CENTERLINE OF STUD.

| RED              | 100  | LOOSE PIECE, BOX    | 8-52410-1 |
|------------------|------|---------------------|-----------|
| NATURAL          | 1000 | LOOSE PIECE         | 1-52410-0 |
| RED              | 5000 | 52410 ON TAPE, REEL | 52410-1   |
| RED              | 1000 | LOOSE PIECE         | 52410     |
| INSULATION COLOR | QTY  | PACKAGING TYPE      | PART NO.  |

|  |  |
|--|--|
| <b>CUSTOMER SERVICE SYSTEMS</b>  |  |
| FOR ADDITIONAL PRODUCT INFORMATION OR COPIES OF DRAWINGS AND TECHNICAL DOCUMENTS | PRODUCT INFORMATION CENTER<br>1-800-522-6752 |
| FOR APPLICATION TOOLING INFORMATION  | TOOLING ASSISTANCE CENTER<br>1-800-722-1111  |
| FOR ORDER ENTRY  | 1-800-526-5142                               |

|  |
|--|
| MAX RECOMMENDED OPERATING TEMPERATURE:<br>105°C [221°F]            |
| VOLTAGE RATING:<br>300 V MAX                                       |
| CIRCULAR MIL AREA:<br>0.26-1.65mm² [509-3260]<br>SOLID OR STRANDED |

|  |  |
|--|--|
| THIS DRAWING IS A CONTROLLED DOCUMENT. |  |
| DIMENSIONS:<br>INCHES                  | TOLERANCES UNLESS OTHERWISE SPECIFIED:   |
|  | 0 PLC ± -<br>1 PLC ± -<br>2 PLC ± .008<br>3 PLC ± -<br>4 PLC ± -<br>ANGLES ± -<br>FINISH |
| MATERIAL                               | -4   |

|                                    |   |                                   |                    |
|------------------------------------|---|-----------------------------------|--------------------|
| DWN<br>JR RUTH<br>10DEC09          | TE Connectivity   |                                   |                    |
| CHK<br>TOM MICHIELUTTI<br>10DEC09  | NAME<br>TERMINAL, SPRING SPADE<br>PIDG, WIRE SIZE 22-16 |                                   |                    |
| APVD<br>TOM MICHIELUTTI<br>10DEC09 | PRODUCT SPEC<br>108-1034                                | APPLICATION SPEC<br>NOT AVAILABLE | RESTRICTED TO<br>- |
| SIZE<br>A3                         | CAGE CODE<br>00779                                      | DRAWING NO<br>C-52410             | SCALE<br>4:1       |
| WEIGHT<br>-                        | SHEET<br>1 OF 1   |                                   | REV<br>K2          |
| CUSTOMER DRAWING                   |   |                                   |                    |

单击下面可查看定价，库存，交付和生命周期等信息

[>>TE Connectivity\(泰科\)](#)