

LOC	DIST	REV	DATE	BY	APP'D
-	-	A	12MAR2008	JM	JM
-	-	A1	02APR2008	JM	JM
-	-	A2	26JUN2008	JM	JM

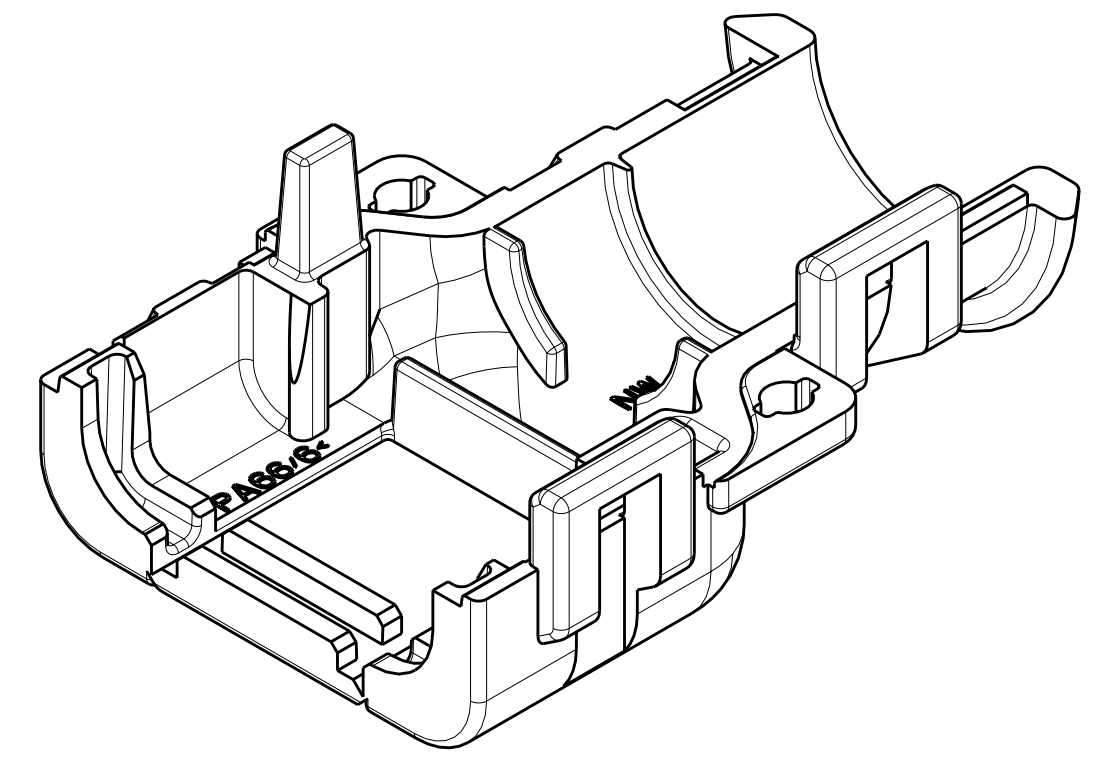

SCALE 3:1

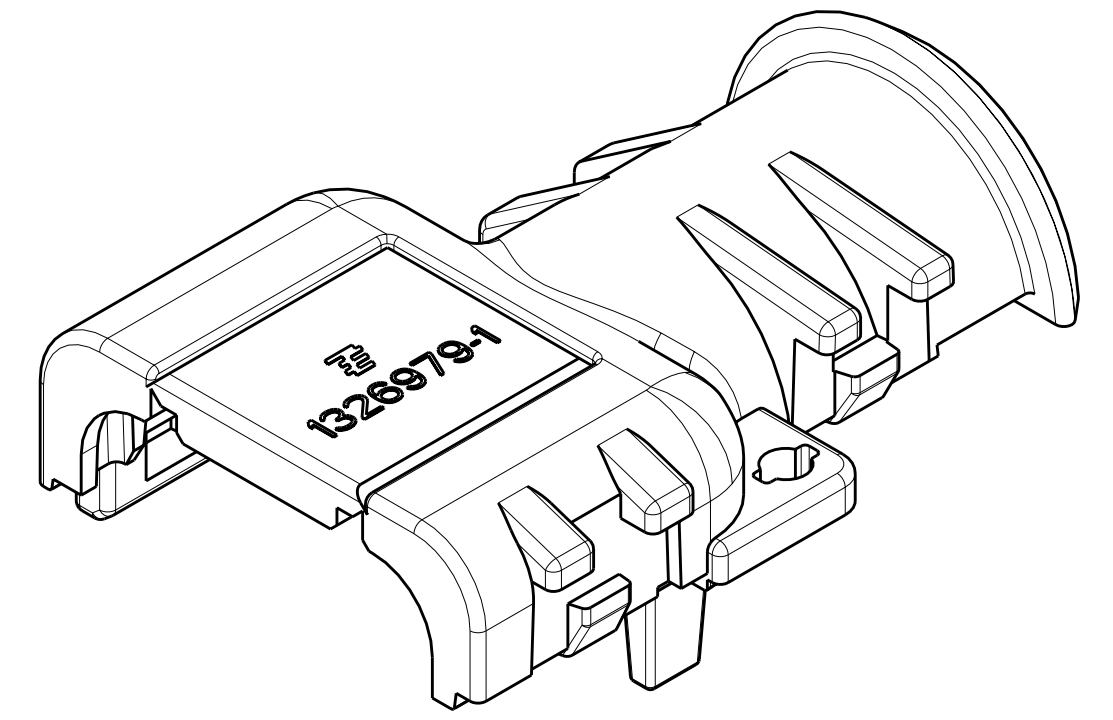

SCALE 3:1

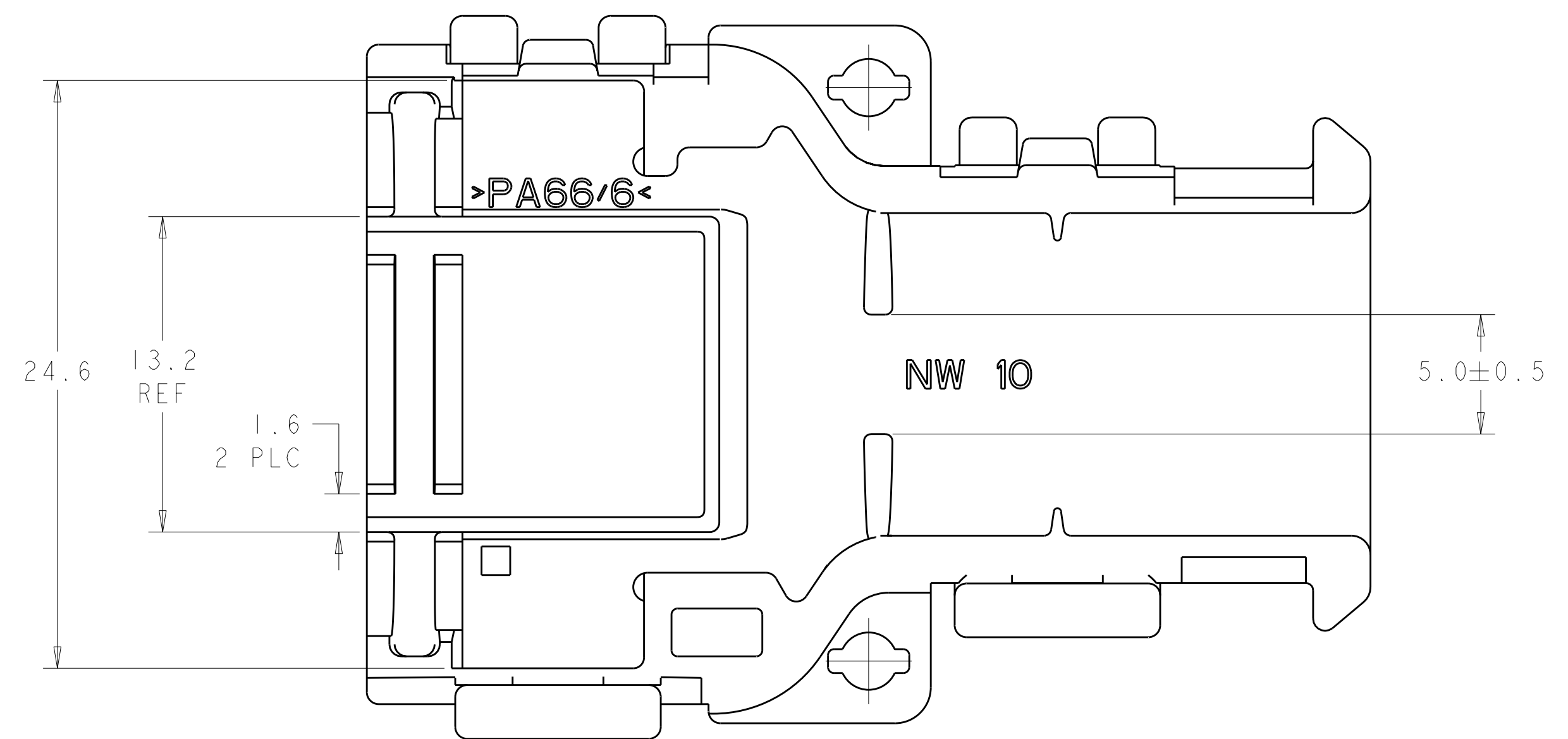
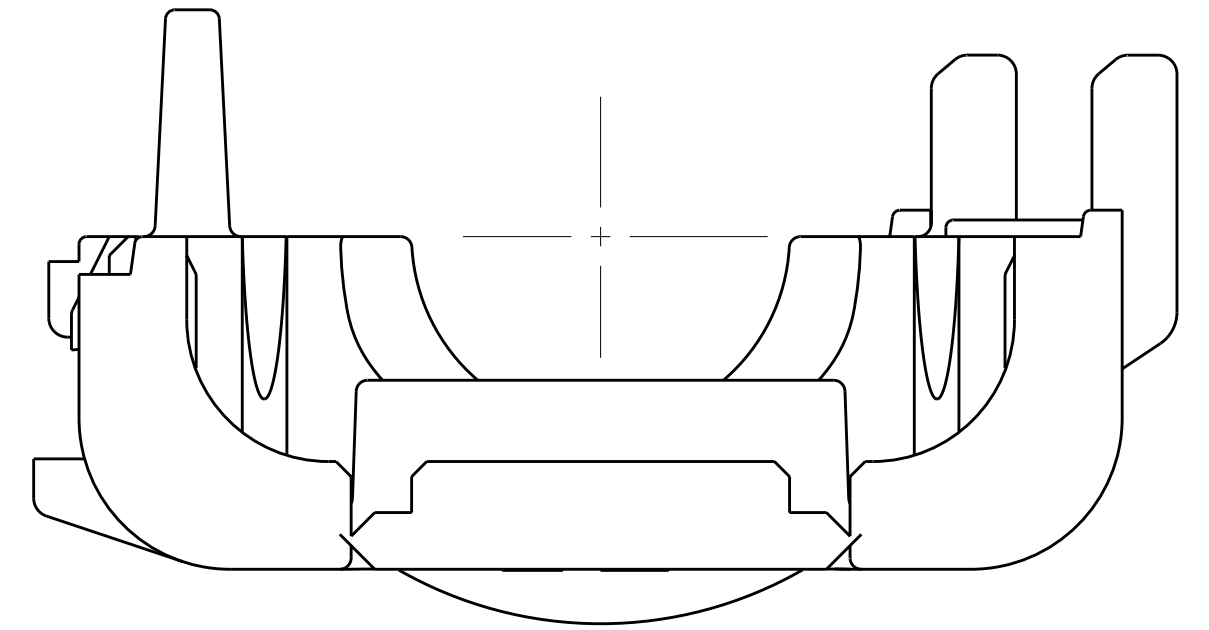

- △ MATERIAL: NYLON MOLDING COMPOUND, BLACK, PA66
- 2. FITS CONDUIT SIZE NW10/METRIC 12
- 3. BACKSHELL DESIGNED SUCH THAT TWO HALVES ATTACH TO ONE ANOTHER AND CLAMSHELL AROUND THE CONNECTOR COVER.
- △ IN ORDER TO MOUNT THE BACKSHELL TO A PLUG CONNECTOR, THIS AREA MUST BE BROKEN OUT ON 1 HALF OF THE CONNECTOR BACKSHELL.

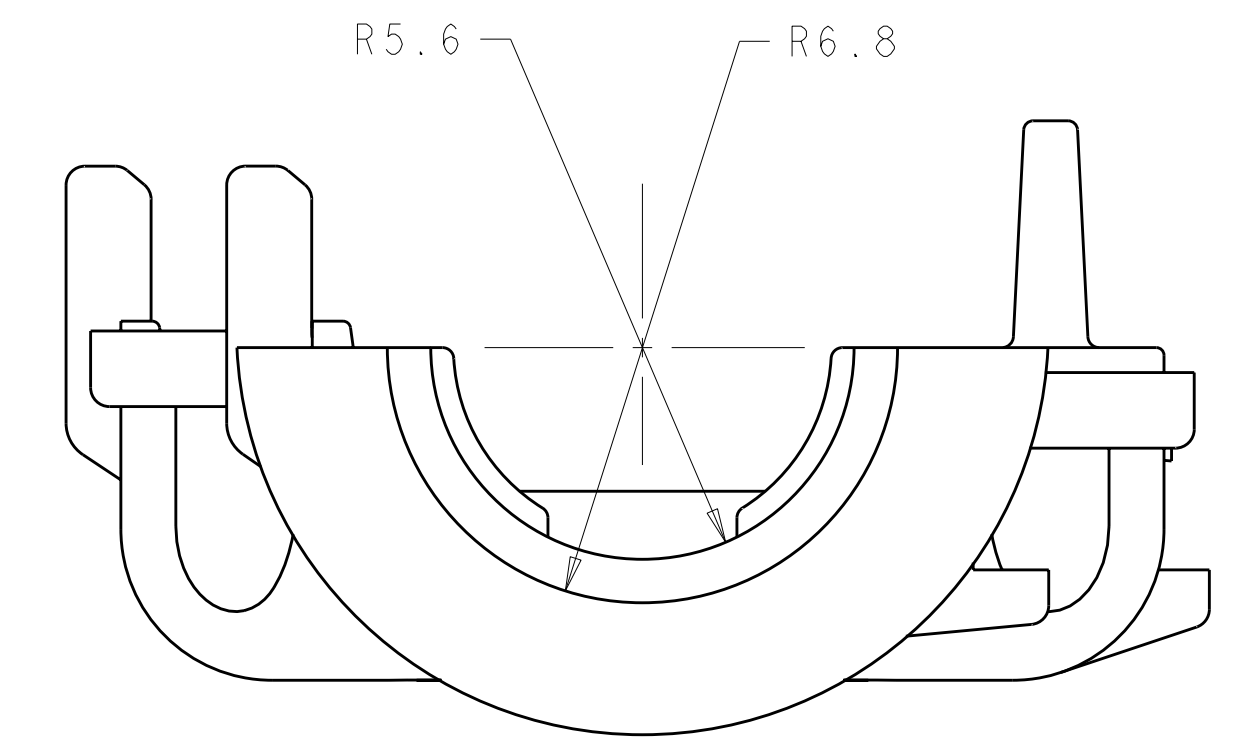
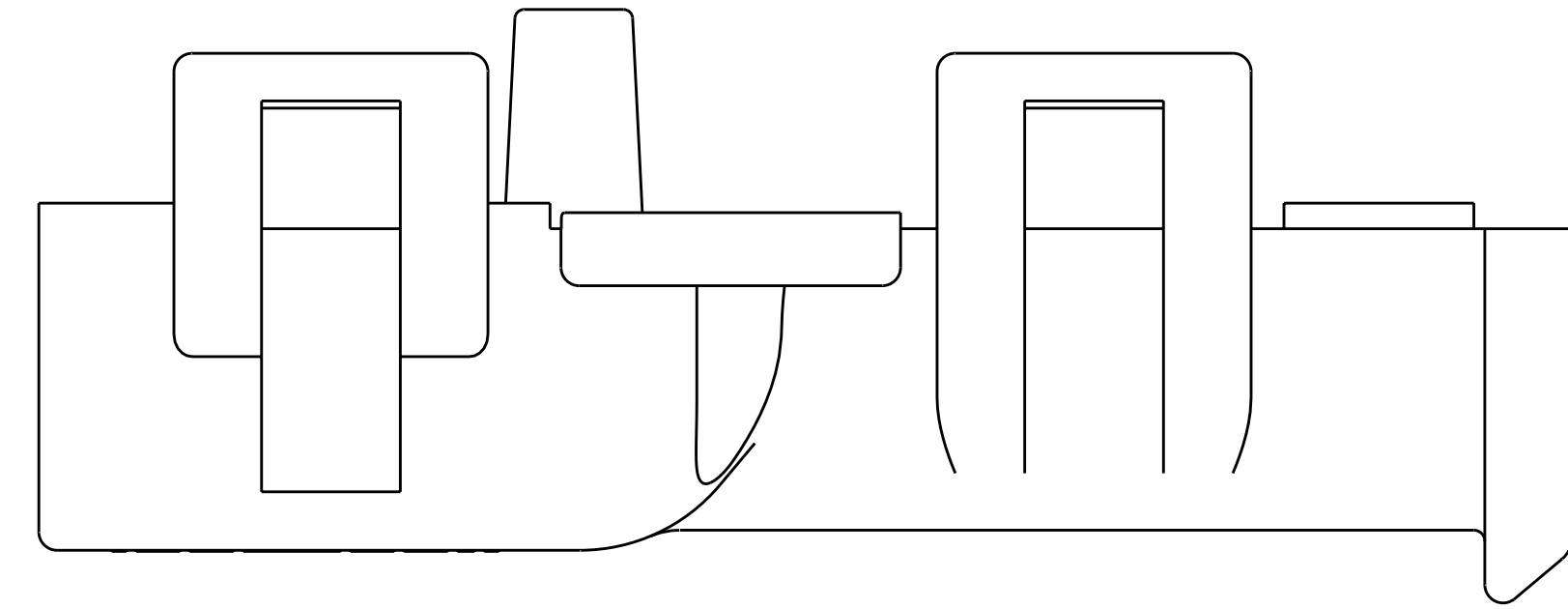

3.0 OR SMALLER TIE WRAP CAN BE USED IN THIS AREA
 5.0 OR SMALLER TIE WRAP CAN BE USED IN THIS AREA

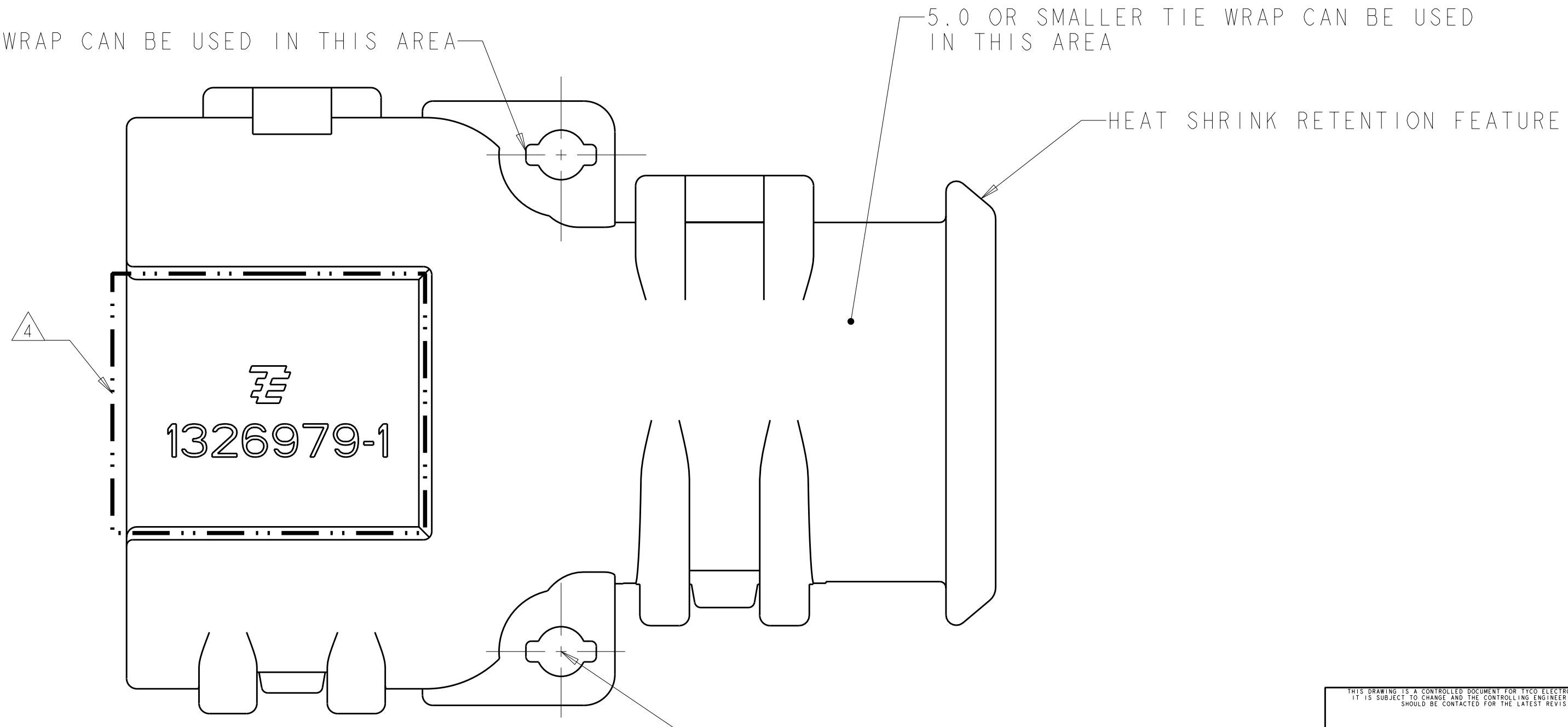

2917mm	AS SHOWN	1326979-1
VOLUME	DESCRIPTION	PART NO.

DIMENSIONS: mm TOLERANCES UNLESS OTHERWISE SPECIFIED: 0 PLC ± 1 PLC ±0.2 2 PLC ± 3 PLC ± 4 PLC ± ANGLES ± FINISH		DWN W. HOELSCHER 04AUG2005 CHK R. SIMMONS 04AUG2005 APVD DAVE KLEIN 04AUG2005 NAME: BACK SHELL, 180 DEGREE, 3 WIRE, NW10 FLEXIBLE CONDUIT, WITH SHRINK TUBE, ADAPTER, AMPSEAL 16 PRODUCT SPEC APPLICATION SPEC SIZE: A100779 CAGE CODE: C=1326979 DRAWING NO: 1326979-1 WEIGHT: - CUSTOMER DRAWING	Tyco Electronics Harrisburg, PA 17105-3608 Tyco Electronics Harrisburg, PA 17105-3608 SCALE 5:1 SHEET 1 OF 1 REV A2
--	--	--	---

单击下面可查看定价，库存，交付和生命周期等信息

[>>TE Connectivity\(泰科\)](#)