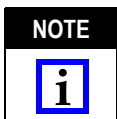

Figure 1

1. INTRODUCTION

XFP Connector 788862-[] or XFP Connector 1367500-1 and Cage Assembly 1489951-1 are used to interconnect XFP fiber optic or copper transceiver modules to host printed circuit (pc) boards. The EMI/dust cover is used to prevent contaminants from entering the chassis and confine any EMI emissions when the transceiver is not installed. See Figure 1.

In applications where heat dissipation is necessary, a heat sink can be used. Choose a heat sink that meets the need of the specific application. A sample of available heat sinks for the cage assembly are shown in Figure 2. These heat sinks are designed to be attached to the cage assembly using a clip.



Dimensions in this instruction sheet are in millimeters. Figures are not drawn to scale.

Reasons for reissue of this instruction sheet are provided in Section 6, REVISION SUMMARY.

2. DESCRIPTION

Each connector contains right-angle surface mount contacts and features a card entry slot that accepts the 1.0±0.1-mm thick integrated circuit card housed in the transceiver.

The cage assembly is a frame with compliant pins for mounting onto the host pc board. The transceiver locking latches hold the transceiver in place, and the hard stop controls the insertion depth of the transceiver. The cage assembly is designed to be bezel mounted. The front flange provides a flat surface to contact the EMI gasket (to be installed onto the perimeter of the bezel cutout) and

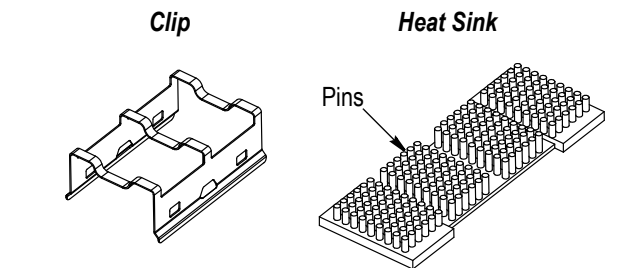

CLIP	HEAT SINK‡	
	With Short Pins	With Long Pins
1489948-1	1542656-1	1542618-1

‡ Other heat sinks are available to meet specific application needs.

Figure 2

stabilizes the cage assembly during insertion and extraction of the transceiver.

3. ASSEMBLY PROCEDURE

1. Install the connector onto the host pc board according to Application Specification 114-13096. Refer to Figure 3. Solder the connector to the board before seating the cage assembly.



The soldering process will cause damage to the cage assembly.

2. Design a pc board support fixture having a flat surface with holes or a channel wide and deep enough to receive any protruding components during seating of the cage assembly on the host pc board.

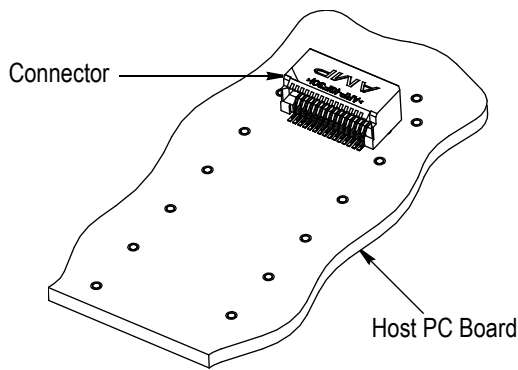

Figure 3

3. Place the host pc board on the pc board support fixture.



CAUTION A pc board support fixture must be used to provide proper support for the host pc board, and to prevent damage to the host pc board and its adjacent components.

4. Align the compliant pins of the cage assembly with the applicable holes in the host pc board. Using even pressure across the cage assembly, apply only that force necessary to seat the shoulders of the compliant pins onto the host pc board. Then remove the pc board support fixture.

5. Inspect the seated cage assembly according to Figure 4.

6. Design the bezel according to 114-13096.

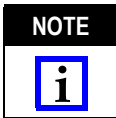

NOTE It is recommended that an EMI gasket be installed onto the back of the bezel. Follow the design requirements for the gasket also given in 114-13096.

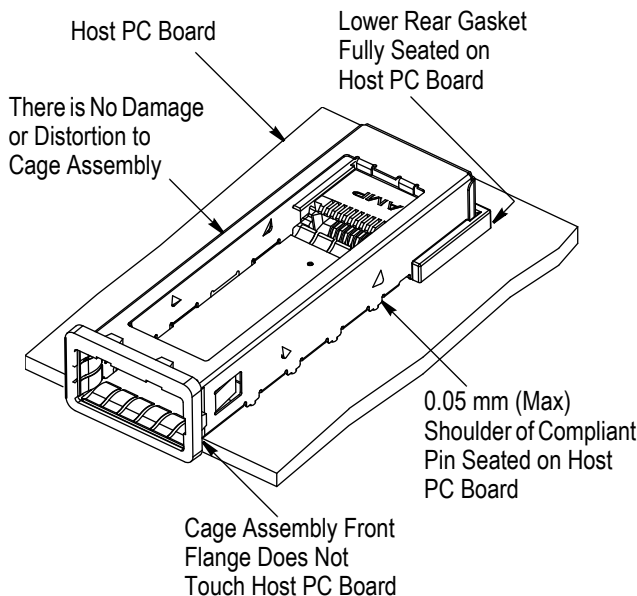

Figure 4

7. Mount the cage assembly (with the host pc board) onto the bezel. Make sure that the opening of the cage assembly is centered over the cutout of the bezel and that the front flange is against the EMI gasket. See Figure 5.



CAUTION To avoid interference with the insertion and extraction of the transceiver, IT IS IMPORTANT that the bezel and pc board be positioned in relation to each other according to Figure 5.

Cage Assembly Installed onto Bezel

Side View

Mounting Connector and Cage Assembly to One Side of Host PC Board

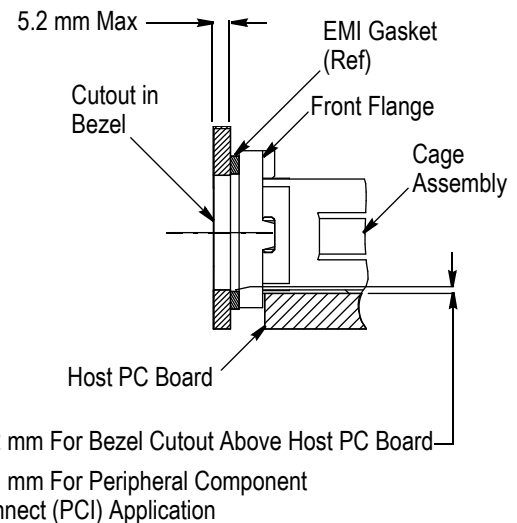

Mounting Connector and Cage Assembly to Both Sides of Host PC Board

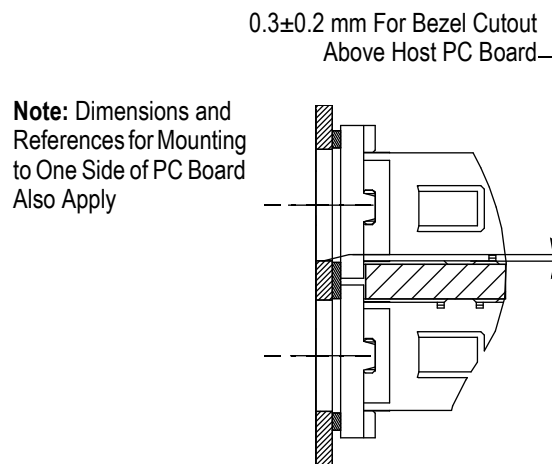

Figure 5

8. If applicable, secure the heat sink to the cage assembly as follows (refer to Figure 6):
 - a. Place the heat sink on the cage assembly so that the raised boss of the heat sink is centered in the cavity of the cage assembly and the perimeter of the heat sink is flush with the top of the frame of the cage assembly.
 - b. Position the cross bars of the clip between the groups of pins of the heat sink. Then seat the clip onto the heat sink.
 - c. Using the tip of a tool (such as a small screwdriver), push the rim of the clip just below either release aperture until the corresponding locking windows latch onto cage locking latches of cage assembly. Repeat this step at the remaining release aperture. Make sure that all four locking latches engage the clip.

Note: For Clarity, Connector, PC Board, and Bezel Are Not Shown

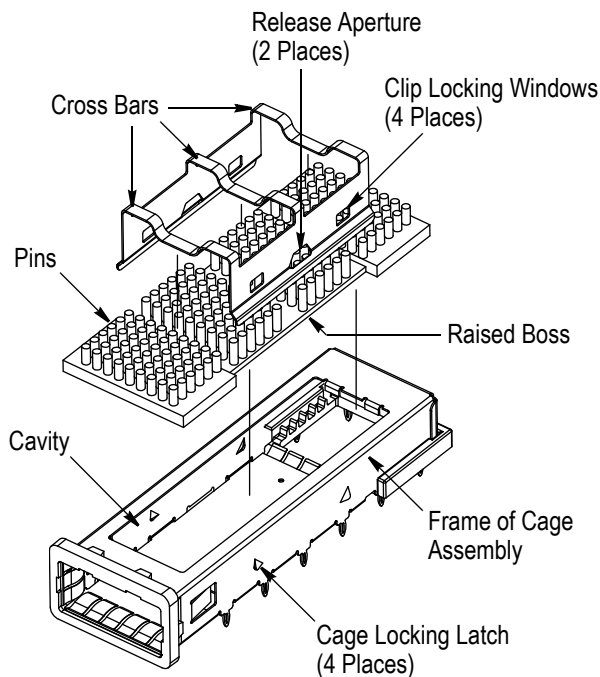

Figure 6

9. Install the transceiver according to 408-8429. If the transceiver is not being installed, install the EMI/dust cover over the opening of the cage assembly.

4. REMOVAL

4.1. Heat Sink

To remove the heat sink from the cage assembly, proceed as follows:

1. Insert the tip of a tool (such as a small screwdriver) into either release aperture of the clip, and rotate the tool until the corresponding locking windows are released from the cage locking latches of the cage assembly. Repeat this step for the remaining release aperture. Refer to Figure 6.

2. Lift the clip and heat sink from the cage assembly.

4.2. Cage Assembly

1. If used, remove the heat sink from the cage assembly according to Paragraph 4.1.

2. Partially insert the dust cover or a flat metal bar (or similar object) into the front of the cage assembly. DO NOT allow the object to touch the connector; otherwise, damage to the contacts could occur.

3. Lift the cage assembly off of the host pc board.

DO NOT re-use the cage assembly after removal.

4.3. Connector

1. Remove the cage assembly according to Paragraph 4.2. (the cage assembly must be removed before removing the connector).

2. Use standard de-soldering methods to remove the connector from the host pc board.

DO NOT re-use the connector after removal.

5. REPLACEMENT AND REPAIR

The connector and cage assembly are not repairable. DO NOT use any defective or damaged products.

6. REVISION SUMMARY

Revisions to this instruction sheet include:

- Updated instruction sheet to corporate requirements
- Changed EMI/dust cover part number and drawing

单击下面可查看定价，库存，交付和生命周期等信息

[>>TE Connectivity\(泰科\)](#)