

THIS DRAWING IS UNPUBLISHED. RELEASED FOR PUBLICATION
 © COPYRIGHT BY TYCO ELECTRONICS CORPORATION. ALL RIGHTS RESERVED.

LOC		DIST		REVISIONS			
P	LTR	DESCRIPTION		DATE	DWN	APVD	
AF	50	C		REV PER ECR 05-018400	05JAN06	JR KR	

1 SUPPLIED IN LOOSE PIECE

- 2 SLOT ACCEPTS 0.64-0.81mm [#22-#20] AWG COPPER MAGNET WIRE. SINGLE OR DOUBLE WIRE OF THE SAME SIZE AND TYPE.
- 3 SPECIAL CAVITY ANVIL LOCATION REQUIRED 4.83±0.07 [.190±.003]. REF APPLICATION SPEC. 114-2046, SEC 3.21, NOTE 7, REVISION T OR LATER.
- 4 BLACK COLORING APPLIED TO THIS SURFACE DURING LOOSE PIECE OPERATION TO PROVIDE COLOR CODING OF MAGNET WIRE RANGE.

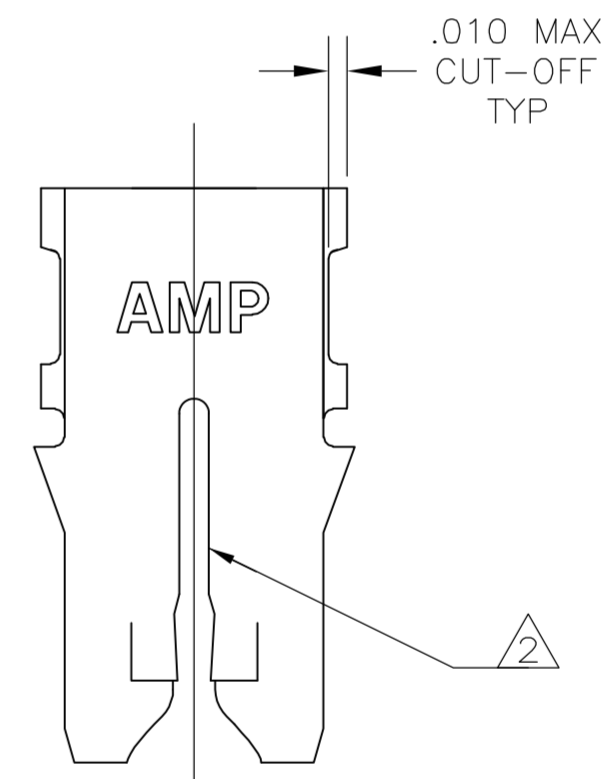
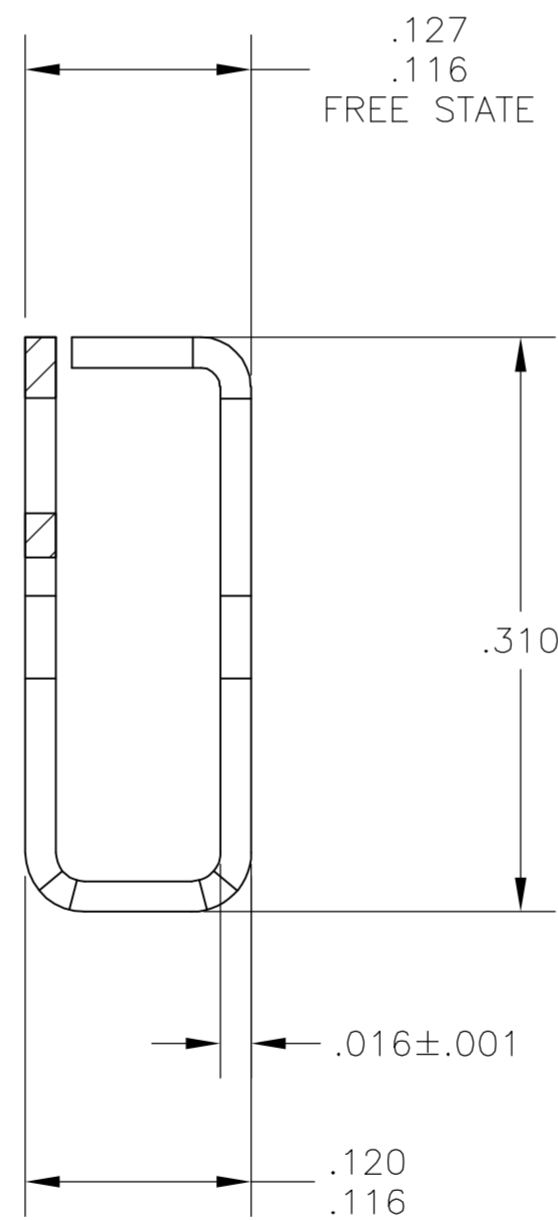
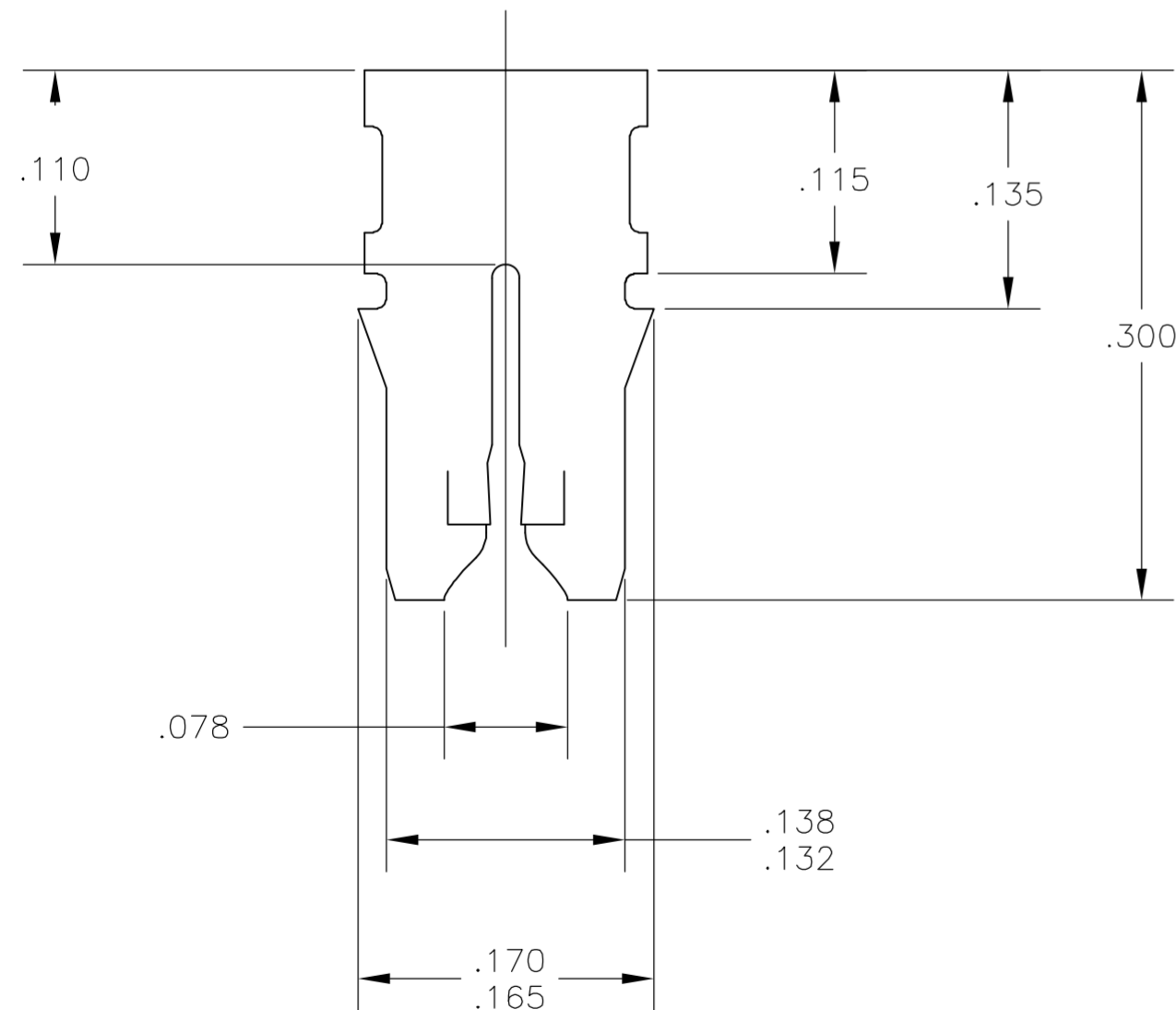
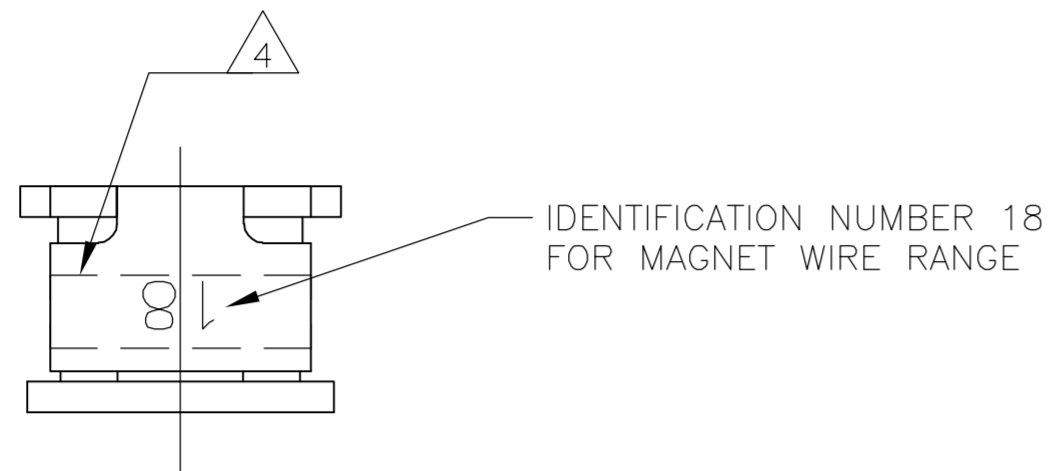

1217974-1
PART NUMBER

THIS DRAWING IS A CONTROLLED DOCUMENT.		DWN jr ruth 15JUL03	Tyco Electronics Corporation Harrisburg, PA 17105-3608	
DIMENSIONS: INCHES		CHK KURT A. RANDOLPH 15JUL03	NAME KURT A. RANDOLPH	
TOLERANCES UNLESS OTHERWISE SPECIFIED:		APVD KURT A. RANDOLPH 15JUL03	PRODUCT SPEC 108-2012	
0 PLC ± - 1 PLC ± - 2 PLC ± .010 3 PLC ± - 4 PLC ± - ANGLES ± -		APPLICATION SPEC 114-2046 3	SIZE A2	CAGE CODE 00779
MATERIAL H04 PHOS BRONZE	FINISH .000080 MIN TIN	WEIGHT -	DRAWING NO 1217974	RESTRICTED TO -
CUSTOMER DRAWING			SCALE 10:1	SHEET 1 of 1
			REV C	

单击下面可查看定价，库存，交付和生命周期等信息

[>>TE Connectivity\(泰科\)](#)