

P	LTR	DESCRIPTION	DATE	DWN	APVD
6		REVISED PER ECR-20-010947	04AUG2020	GK	AK

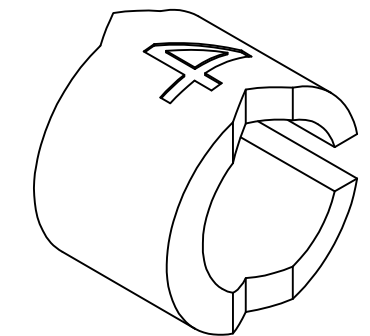

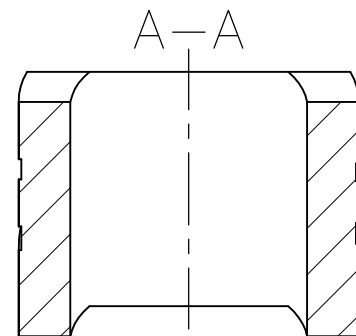
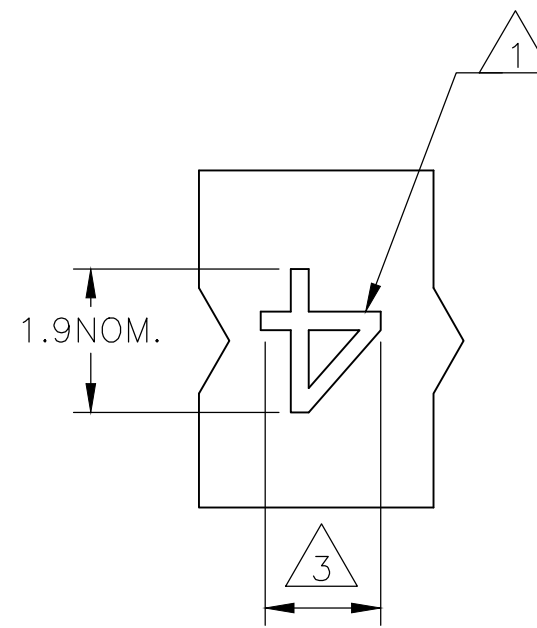
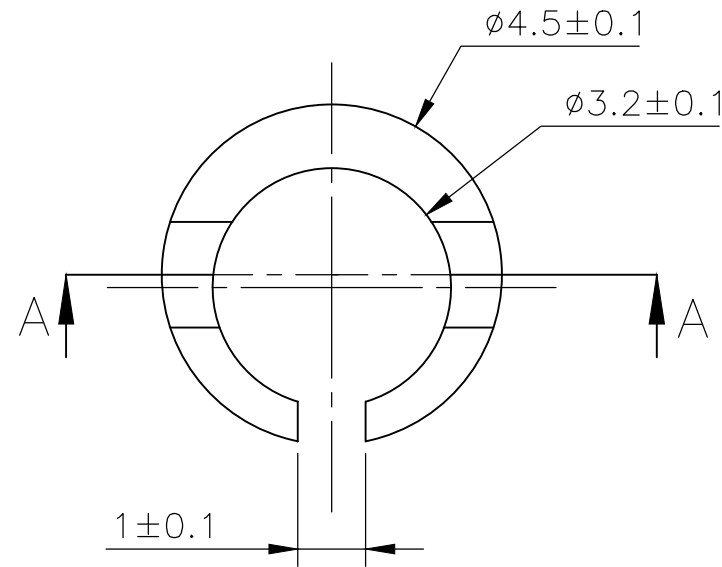
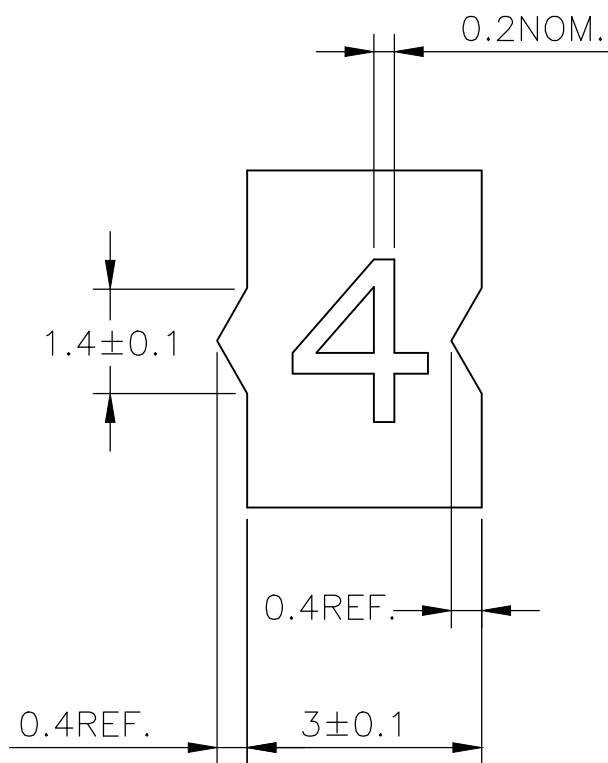

NOTES:

- △1 FOR PART NUMBERS SEE SHEET 3 OF 3.
- △2 MARK SHOULD BE CENTRALLY POSITIONED ± 0.1 mm
- △3 WIDTH OF MARK DEPENDS ON CHARACTER PRINTED

THIS DRAWING IS A CONTROLLED DOCUMENT.		DWN RAGHAVENDRA K 23MAR2013	TE Connectivity														
		CHK KEAN ALAN 23MAR2013															
DIMENSIONS: mm		APVD MARIO APPELLO 23MAR2013	NAME SNAP-ON MARKER STB/STD SIZE 09 WITH APPLICATOR														
TOLERANCES UNLESS OTHERWISE SPECIFIED:		PRODUCT SPEC	-														
<table border="0"> <tr><td>0 PLC</td><td>± -</td></tr> <tr><td>1 PLC</td><td>± -</td></tr> <tr><td>2 PLC</td><td>± -</td></tr> <tr><td>3 PLC</td><td>± -</td></tr> <tr><td>4 PLC</td><td>± -</td></tr> <tr><td>ANGLES</td><td>± -</td></tr> </table>		0 PLC	± -	1 PLC	± -	2 PLC	± -	3 PLC	± -	4 PLC	± -	ANGLES	± -	APPLICATION SPEC	-		
0 PLC	± -																
1 PLC	± -																
2 PLC	± -																
3 PLC	± -																
4 PLC	± -																
ANGLES	± -																
MATERIAL		WEIGHT	SIZE	CAGE CODE	DRAWING NO	RESTRICTED TO											
-		-	A3	C2290	C-1-1198185-1	-											
CUSTOMER DRAWING			SCALE	SHEET	REV												
			NTS	1 OF 3	6												

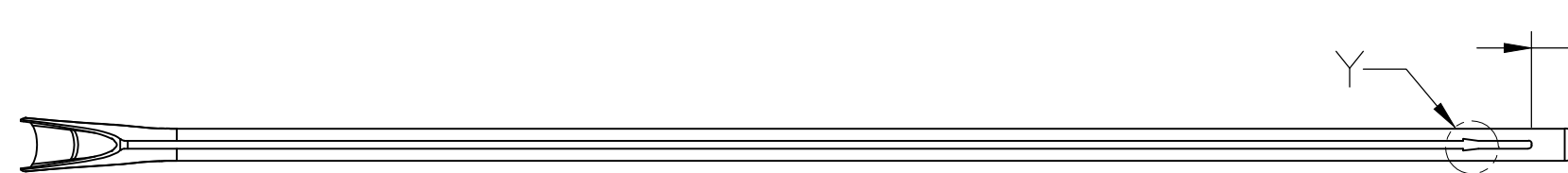
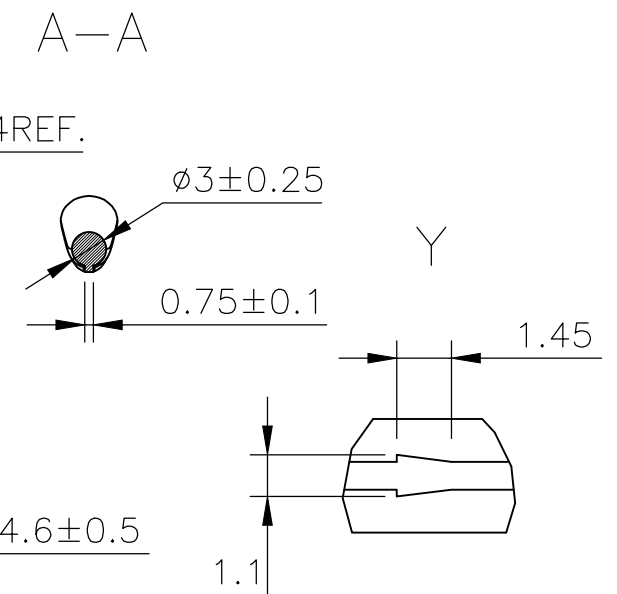
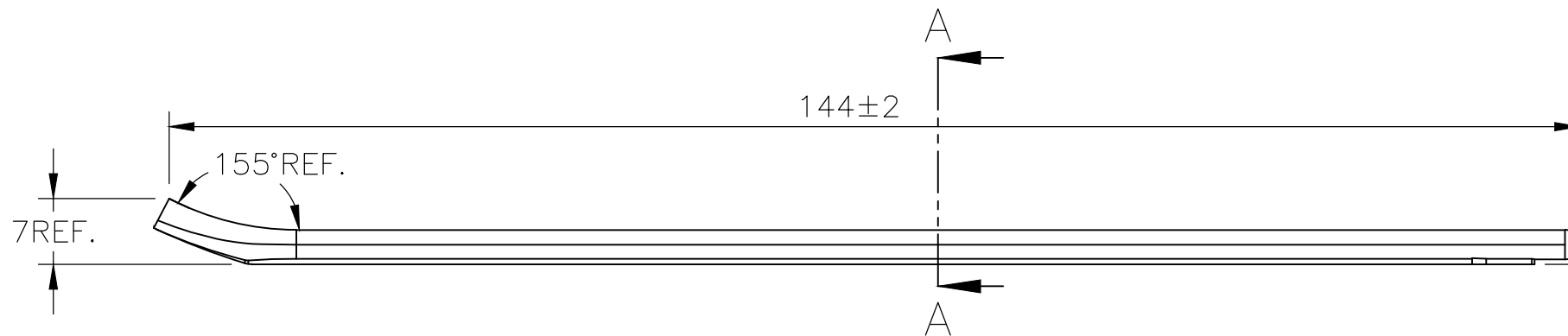
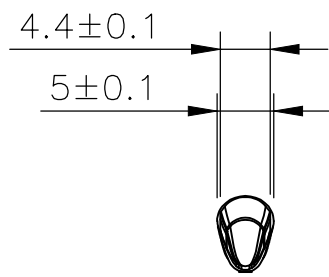
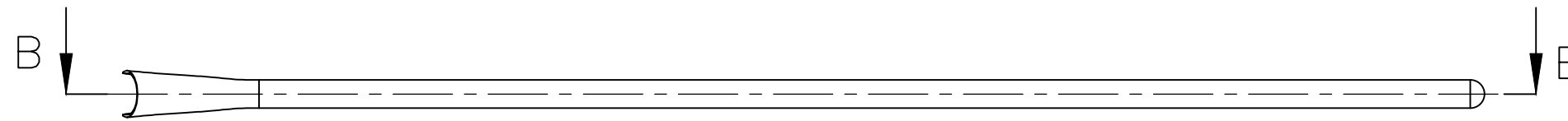
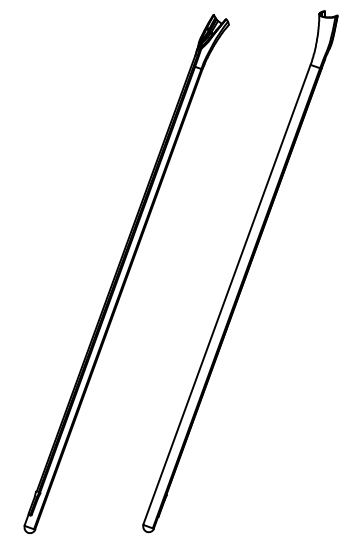
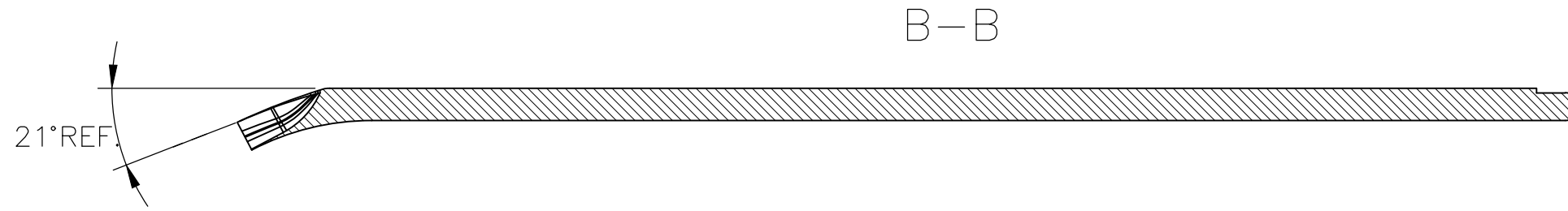
P	LTR	DESCRIPTION	DATE	DWN	APVD
-	-	SEE SHEET 1	-	-	-



THIS DRAWING IS A CONTROLLED DOCUMENT.		DWN RAGHAVENDRA K 23MAR2013	 TE Connectivity		
DIMENSIONS: mm		CHK KEAN ALAN 23MAR2013			
TOLERANCES UNLESS OTHERWISE SPECIFIED: 0 PLC ± - 1 PLC ± - 2 PLC ± - 3 PLC ± - 4 PLC ± - ANGLES ± -		APVD MARIO APPELLO 23MAR2013	NAME SNAP-ON MARKER STB/STD SIZE 09 WITH APPLICATOR		
MATERIAL -		FINISH -	PRODUCT SPEC -	APPLICATION SPEC -	RESTRICTED TO -
		WEIGHT -	SIZE A3	CAGE CODE C2290	DRAWING NO G-1-1198185-1
CUSTOMER DRAWING			SCALE NTS	SHEET 2 OF 3	REV 6

REVISIONS

P	LTR	DESCRIPTION	DATE	DWN	APVD
	-	SEE SHEET 1	-	-	-

DESCRIPTION	PART NO.
STB09-0-0	1768039-4
STB09-1-1	1768039-6
STB09-2-2	1768039-9
STB09-3-3	1-1768039-2
STB09-5-5	1-1768039-6
STB09-6-6	1-1768039-8
STB09-7-7	1-1768039-9
STB09-8-8	2-1768039-0
STB09-BLANK-0	2-1768039-4
STB09-BLANK-1	2-1768039-5
STB09-BLANK-2	2-1768039-6
STB09-BLANK-3	2-1768039-7
STB09-BLANK-5	2-1768039-8
STB09-BLANK-6	2-1768039-9
STB09-BLANK-7	3-1768039-0
STB09-BLANK-8	3-1768039-1
STD09W/1-12	7-1768710-9
STD09W/SA	3-1768044-5
STD09W/SAB	3-1768044-6
STD09W-0	808756-000
STD09W-1	564314-000
STD09W-2	881128-000
STD09W-3	451612-000
STD09W-4	776688-000
STD09W-5	411220-000
STD09W-6	062724-000
STD09W-7	638470-000
STD09Y-SLASH	792924-000
STB09-C-2	3-1768039-2
STB09-T-2	4-1768039-2
STD09W-AC	3-1768044-8
STD09Y/SA	5-1768044-7

4

4

4

4

4

DESCRIPTION	PART NO.
STD09W-8	671050-000
STD09W-9	519158-000
STD09W-A	317872-000
STD09W-A-LC	3-1768044-9
STD09W-B	929926-000
STD09W-BLANK	4-1768044-0
STD09W-B-LC	4-1768044-1
STD09W-C	595148-000
STD09W-COLON	950990-000
STD09W-D	535494-000
STD09W-D-LC	4-1768044-2
STD09W-DOT	4-1768044-3
STD09W-E	318782-000
STD09W-EARTH	4-1768044-4
STD09W-F	778086-000
STD09W-G	362886-000
STD09W-H	659958-000
STD09W-I	234392-000
STD09W-J	429560-000
STD09W-K	594054-000
STD09W-K-LC	5-1768044-0
STD09W-L	591020-000
STD09W-L-LC	5-1768044-1
STD09W-M	853188-000
STD09W-MINUS	5-1768044-2
STD09W-N	547972-000
STD09W-P	294582-000

4 OBSOLETE PART

DESCRIPTION	PART NO.
STD09W-PLUS	5-1768044-5
STD09W-Q	702368-000
STD09W-R	071620-000
STD09W-S	701134-000
STD09W-SLASH	190726-000
STD09W-T	594256-000
STD09W-U	588548-000
STD09W-V	651644-000
STD09W-W	910358-000
STD09W-X	697154-000
STD09W-Y	068920-000
STD09W-Z	952914-000
STD09Y-0	047316-000
STD09Y-1	064090-000
STD09Y-2	700690-000
STD09Y-3	410908-000
STD09Y-4	422172-000
STD09Y-5	131226-000
STD09Y-6	746782-000
STD09Y-7	007980-000
STD09Y-8	634544-000
STD09Y-9	645636-000
STD09Y-A	862816-000
STD09Y-AC	6-1768044-0
STD09Y-B	036610-000
STD09Y-BLANK	6-1768044-2
STD09Y-C	452642-000

DESCRIPTION	PART NO.
STD09Y-COLON	6-1768044-4
STD09Y-D	281690-000
STD09Y-DOT	6-1768044-6
STD09Y-E	882530-000
STD09Y-EARTH	6-1768044-7
STD09Y-F	017172-000
STD09Y-G	112902-000
STD09Y-H	075034-000
STD09Y-I	769976-000
STD09Y-J	327448-000
STD09Y-K	672532-000
STD09Y-L	509762-000
STD09Y-M	205508-000
STD09Y-MINUS	7-1768044-5
STD09Y-N	667860-000
STD09Y-P	597516-000
STD09Y-PLUS	7-1768044-8
STD09Y-Q	247002-000
STD09Y-R	920140-000
STD09Y-S	590022-000
STD09Y-T	497634-000
STD09Y-U	491394-000
STD09Y-V	423154-000
STD09Y-W	365646-000
STD09Y-X	523918-000
STD09Y-Y	362942-000
STD09Y-Z	322370-000

THIS DRAWING IS A CONTROLLED DOCUMENT.

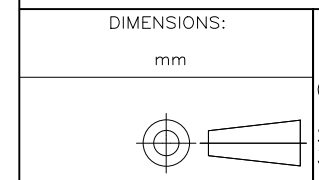

DIMENSIONS:	TOLERANCES UNLESS OTHERWISE SPECIFIED:
mm	
0 PLC	± -
1 PLC	± -
2 PLC	± -
3 PLC	± -
4 PLC	± -
ANGLES	± -
FINISH	

DWN	23MAR2013	RAGHAVENDRA K
CHK	23MAR2013	KEAN ALAN
APVD	23MAR2013	MARIO APPELLO
PRODUCT SPEC		
APPLICATION SPEC		
WEIGHT		-



NAME SNAP-ON MARKER STB/STD SIZE 09 WITH APPLICATOR

SIZE	CAGE CODE	DRAWING NO	RESTRICTED TO
A3	C2290	C-1-1198185-1	-

单击下面可查看定价，库存，交付和生命周期等信息

[>>TE Connectivity\(泰科\)](#)