

THIS DRAWING IS UNPUBLISHED. RELEASED FOR PUBLICATION FEB ,1997.
 © COPYRIGHT 1997 By - ALL RIGHTS RESERVED.

LOC	DIST	REVISIONS					
J		P	LTR	DESCRIPTION	DATE	DWN	APVD
			C	REVISED ECR-12-004537	21MAR2012	I.T	S.Y

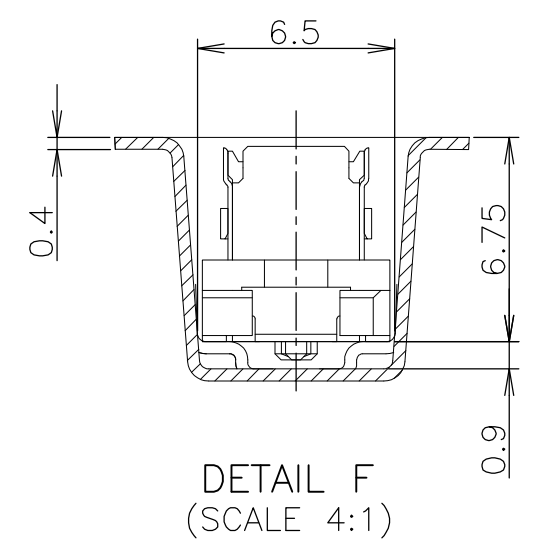

CONNECTOR DETAIL

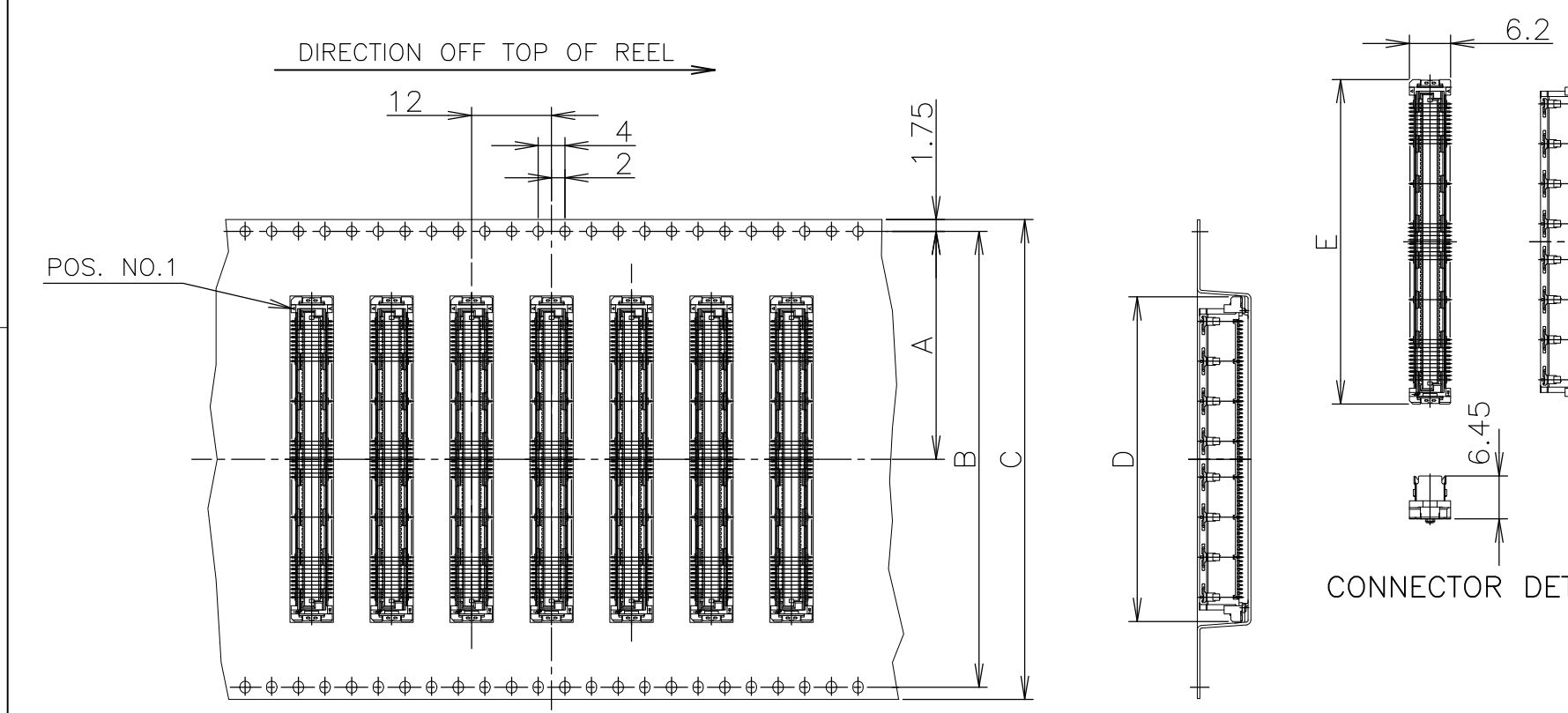
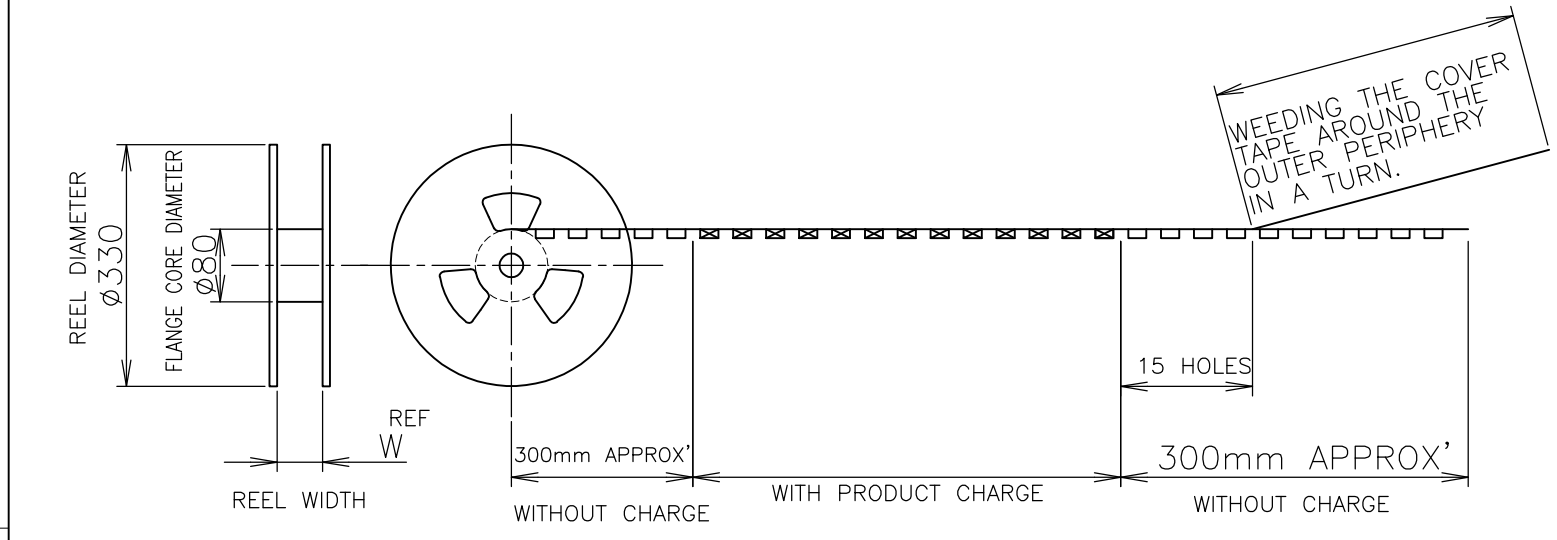
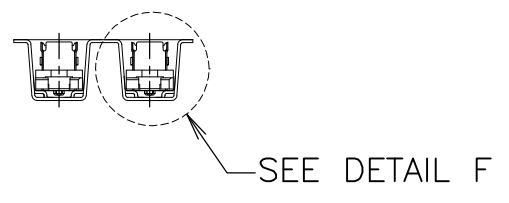

SEALANT	TOOLING STATUS	QTY.	W	E	D	C	B	A	POS.	PART NO.
NOT AVAILABLE		700	77.5	54.7	55	72	68.4	34.2	160	6-5353831-1
			77.5	48.7	49	72	68.4	34.2	140	6- -0
			61.5	42.7	43	56	52.4	26.2	120	5- -9
			61.5	36.7	37	56	52.4	26.2	100	5- -8
			61.5	33.7	34	56	52.4	26.2	90	5- -7
			49.5	27.7	28	44	40.4	20.2	70	5- -5
			49.5	24.7	25	44	40.4	20.2	60	5- -4
			37.5	21.7	22	32	28.4	14.2	50	5- -3
			37.5	18.7	19	32	28.4	14.2	40	5- -2
NOT AVAILABLE		700	29.5	15.7	16	24	11.5		30	5-5353831-1
NON SEALANT			77.5	54.7	55	72	68.4	34.2	160	1-5353831-1
			77.5	48.7	49	72	68.4	34.2	140	1- -0
			61.5	42.7	43	56	52.4	26.2	120	-9
	AVAILABLE		61.5	36.7	37	56	52.4	26.2	100	-8
	NOT AVAILABLE		61.5	33.7	34	56	52.4	26.2	90	-7
	NOT AVAILABLE		49.5	27.7	28	44	40.4	20.2	70	-5
			49.5	24.7	25	44	40.4	20.2	60	-4
			37.5	21.7	22	32	28.4	14.2	50	-3
			37.5	18.7	19	32	28.4	14.2	40	-2
NOT AVAILABLE		700	29.5	15.7	16	24	11.5		30	5353831-1

THIS PRODUCT WAS COATED BY FLUX-PENETRATION INHIBITING AGENT.

GENERAL TOLERANCE 一般公差

10 ≥	±0.2
30 ≥	>10: ±0.25
100 ≥	>30: ±0.3
ANGLES: ±3°	

THIS DRAWING IS A CONTROLLED DOCUMENT.

DIMENSIONS: 单位: 耗 mm

TOLERANCES UNLESS OTHERWISE SPECIFIED: 一般公差

0 PLC	± -
1 PLC	± -
2 PLC	± -
3 PLC	± -
4 PLC	± -
ANGLES	± -

FINISH 仕上

MATERIAL 材料

DWN HAWKING HE 08DEC04

CHK STEVEN YAO 08DEC04

APVD I.ENOMOTO 08DEC04

NAME 名称

PRODUCT SPEC 製品規格

108-60047

APPLICATION SPEC 取付適用規格

114-5255

WEIGHT

CUSTOMER DRAWING

SCALE 尺度 1:1

SHEET 1 OF 3

REV C

STE TE Connectivity

EMBOSS ASSY

FH 0.6BTB CONNECTOR

PLUG 7H WITH G-PLATE

SIZE A3

CAGE CODE 00779

DRAWING NO 番号 G-5353831

RESTRICTED TO

THIS DRAWING IS UNPUBLISHED. RELEASED FOR PUBLICATION FEB, 1997.
 © COPYRIGHT 1997 By - ALL RIGHTS RESERVED.

LOC		DIST		REVISIONS			DATE	DWN	APVD
J				P	LTR	DESCRIPTION			
					-	SEE SHEET 1	-	-	-

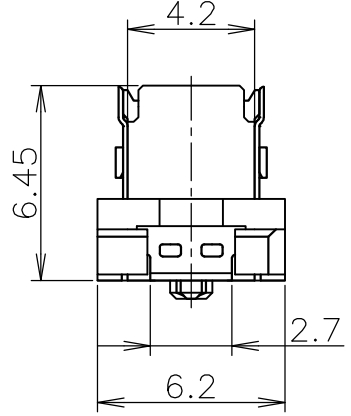
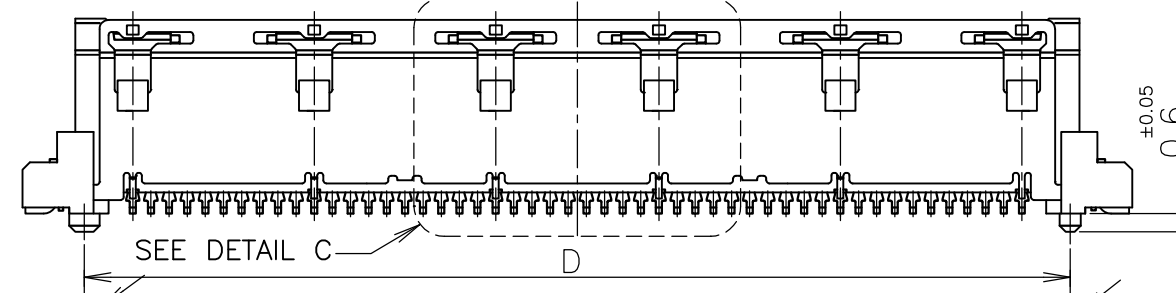
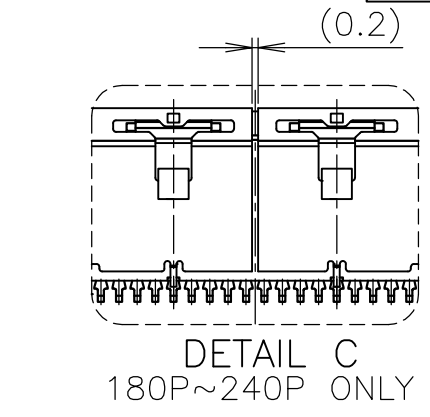
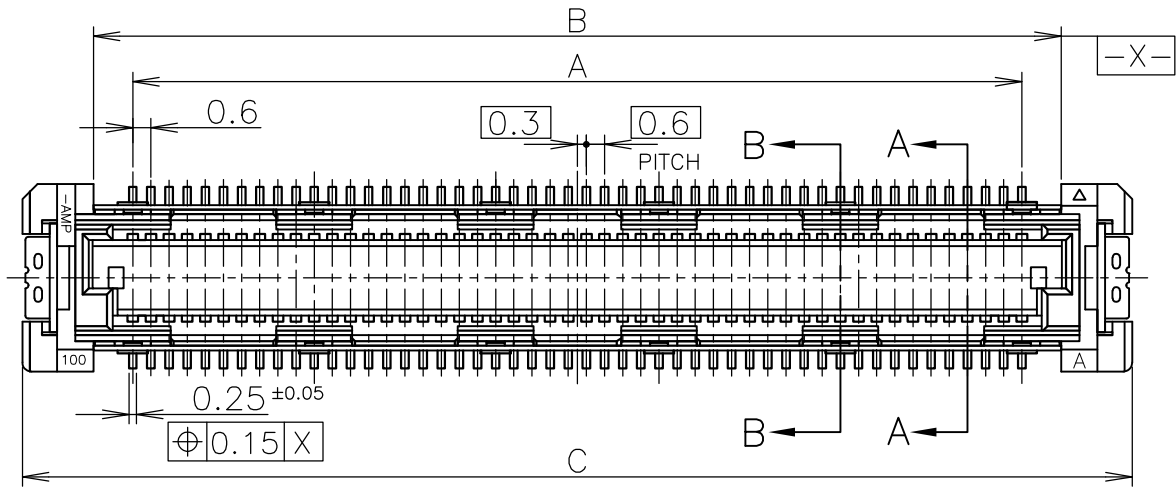

- ① MATERIAL ; HOUSING : HIGH TEMP THERMO PLASTIC UL94V-0
CONTACT : COPPER ALLOY
- ② FINISH ; UNDER PL Ni 0.0013mm MIN ALL OVER.
CONTACT AREA 0.0002 MIN Au PL.
SOLDERING AREA 0.001 MIN TIN PL.
- ③ THIS POSITION IS GROUND CIRCUIT.
- ④ THIS POSITION ITEM IS SECIAL.(FOR CUSTUM MADE)

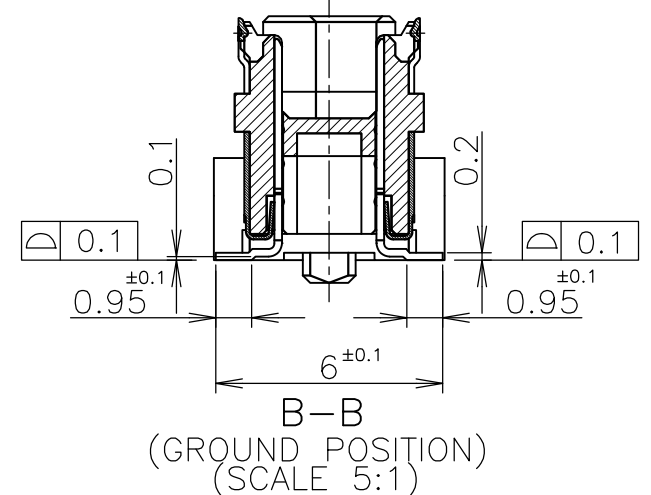
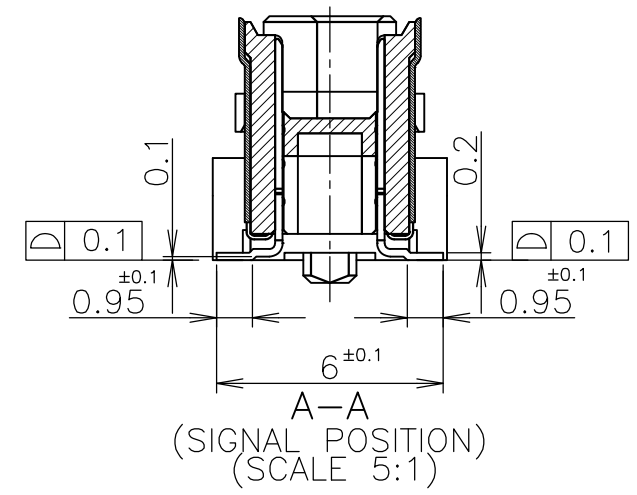
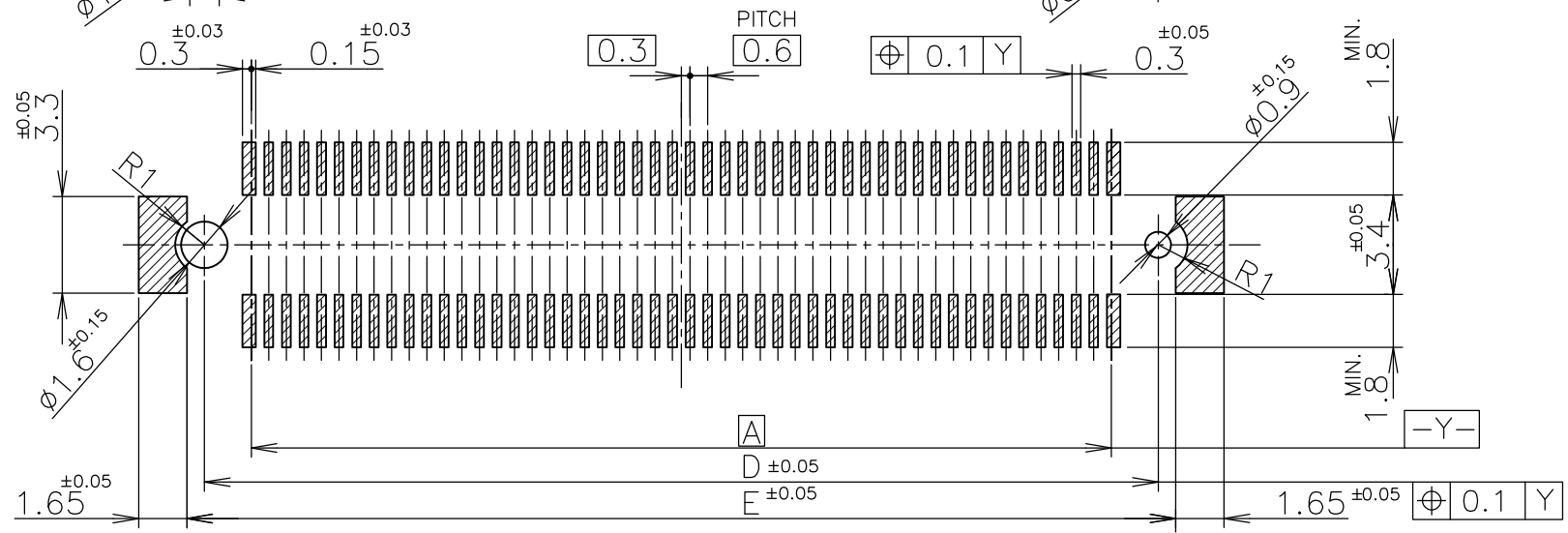

REFERENCE P.C.BOARD LAYOUT

NOT AVAILABLE	75.8	74.6	78.7	74	71.4	240	④
NOT AVAILABLE	51.8	50.6	54.7	50	47.4	160	
NOT AVAILABLE	45.8	44.6	48.7	44	41.4	140	
NOT AVAILABLE	39.8	38.6	42.7	38	35.4	120	
AVAILABLE	33.8	32.6	36.7	32	29.4	100	
NOT AVAILABLE	30.8	29.6	33.7	29	26.4	90	
NOT AVAILABLE	24.8	23.6	27.7	23	20.4	70	
	21.8	20.6	24.7	20	17.4	60	
	19.8	17.6	21.7	17	14.4	50	
	15.8	14.6	18.7	14	11.4	40	
NOT AVAILABLE	12.8	11.6	15.7	11	8.4	30	
TOOLING STATUS	E	D	C	B	A	POS	

GENERAL TOLERANCE
 一般公差
 10≥:±0.2
 30≥ >10:±0.25
 100≥ >30:±0.3
 ANGLES:±3°

THIS DRAWING IS A CONTROLLED DOCUMENT.

DIMENSIONS: 單位: 耗 mm	TOLERANCES UNLESS OTHERWISE SPECIFIED: 一般公差	DWN	TE Connectivity					
	0 PLC ±- 1 PLC ±- 2 PLC ±- 3 PLC ±- 4 PLC ±- ANGLES ±-	CHK				NAME 名稱		
		APVD				EMBOSS ASSY FH 0.6BTB CONNECTOR PLUG 7H WITH G-PLATE		
		PRODUCT SPEC 製品規格				SIZE	CAGE CODE	DRAWING NO 番号
MATERIAL 材料	FINISH 仕上	APPLICATION SPEC 取付適用規格	WEIGHT	A300779	C-5353831			
CUSTOMER DRAWING			SCALE 尺度 4:1	SHEET 2 OF 3	REV C			

THIS DRAWING IS UNPUBLISHED. RELEASED FOR PUBLICATION FEB , 1997.
 © COPYRIGHT 1997 By - ALL RIGHTS RESERVED.

LOC	DIST	REVISIONS		
J		变更	DESCRIPTION	DATE
		P	LTR	DWN
		SEE SHEET 1		
				APVD

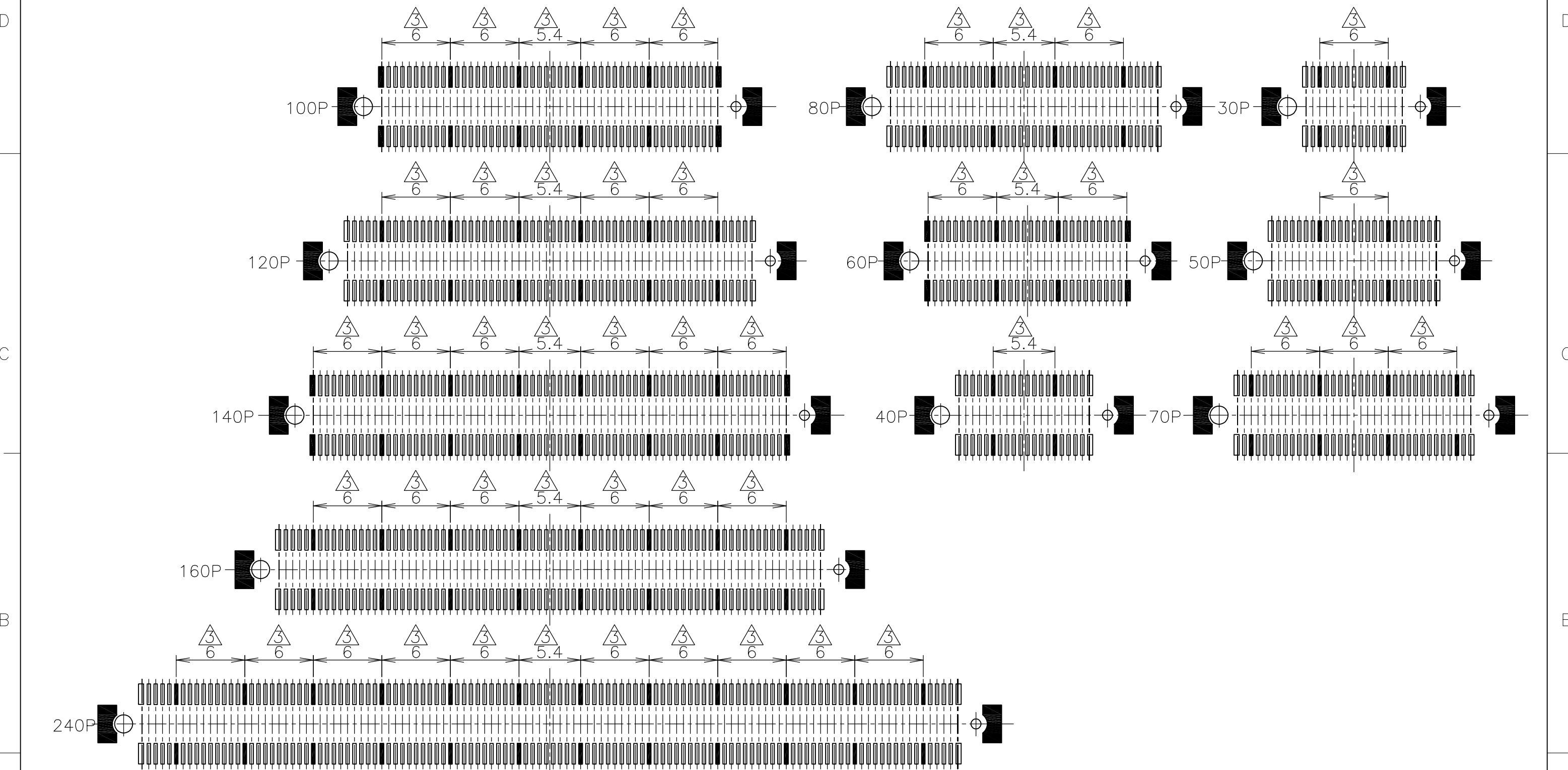

GENERAL TOLERANCE
一般公差

10 ≥	±0.2
30 ≥	>10: ±0.25
100 ≥	>30: ±0.3
ANGLES: ±3°	

THIS DRAWING IS A CONTROLLED DOCUMENT.

DIMENSIONS: 单位: 耗 mm	TOLERANCES UNLESS OTHERWISE SPECIFIED: 一般公差
	0 PLC ± -
	1 PLC ± -
	2 PLC ± -
	3 PLC ± -
	4 PLC ± -
	ANGLES ± -
MATERIAL 材料	FINISH 仕上

DWN	
CHK	
APVD	
PRODUCT SPEC 製品規格	
APPLICATION SPEC 取付適用規格	
WEIGHT	
CUSTOMER DRAWING	

STE TE Connectivity			
NAME 名称			
EMBOSS ASSY FH 0.6BTB CONNECTOR PLUG 7H WITH G-PLATE			
SIZE	CAGE CODE	DRAWING NO 番号	RESTRICTED TO
A3	00779	G-5353831	
SCALE 尺度 3:1		SHEET 3 OF 3	REV C

单击下面可查看定价，库存，交付和生命周期等信息

[>>TE Connectivity\(泰科\)](#)