

THIS DRAWING IS UNPUBLISHED. RELEASED FOR PUBLICATION  
 © COPYRIGHT BY TYCO ELECTRONICS CORPORATION. ALL INTERNATIONAL RIGHTS RESERVED.

LOC	DIST	REVISIONS			
P	LTR	DESCRIPTION	DATE	DWN	APVD
AG	53	C1	REVISED PER ECO-08-021128	02SEP08	DH DB

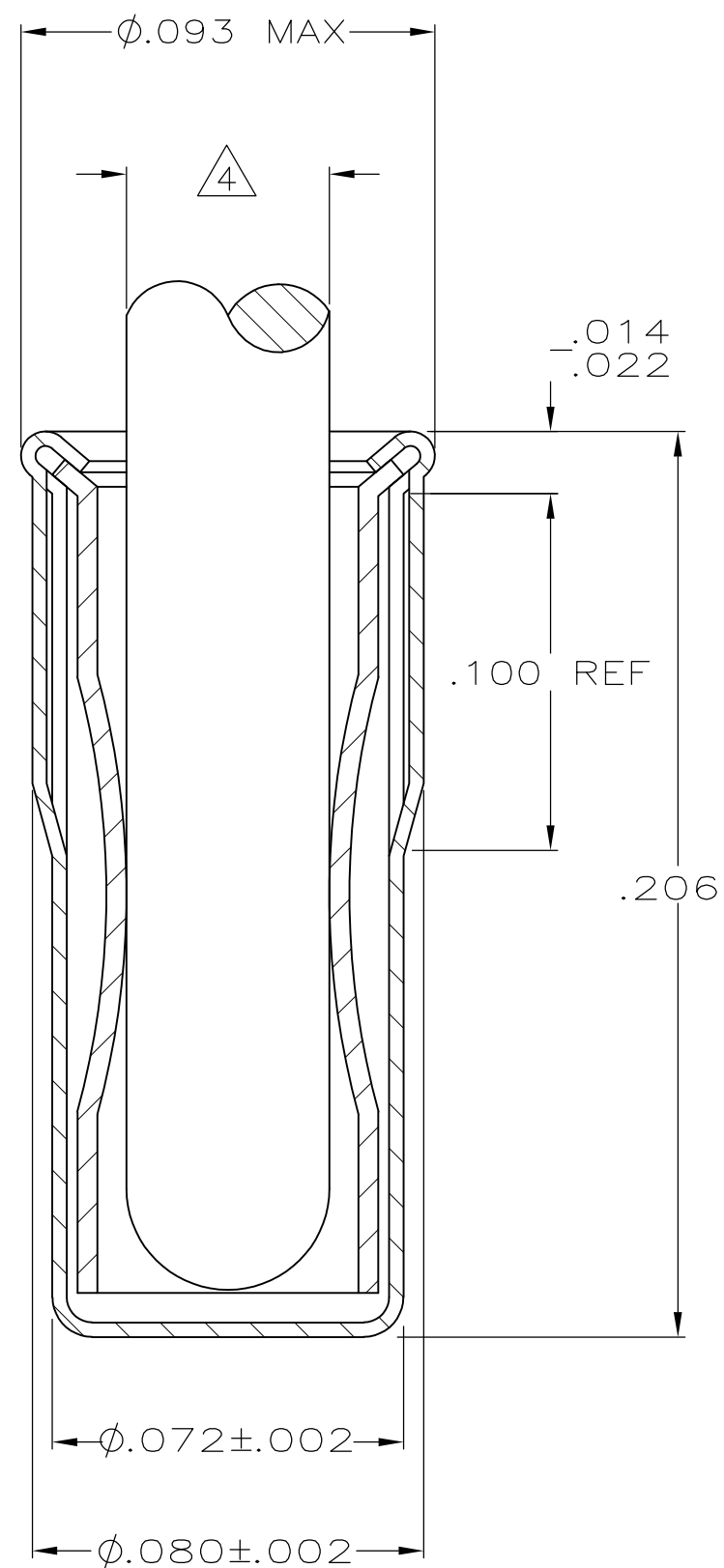
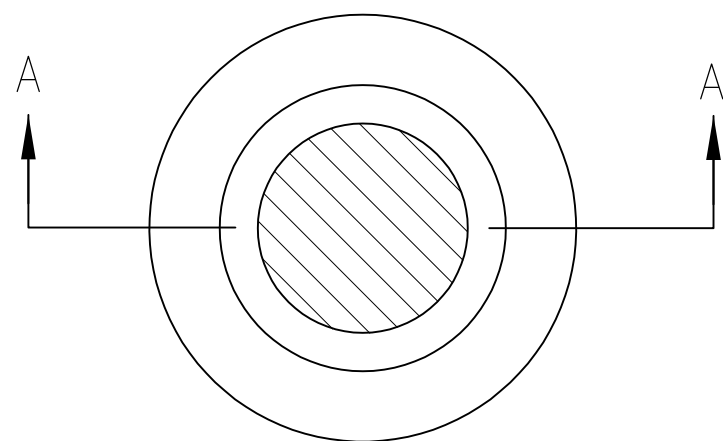

SECTION A-A

- 1 PLATING:  
 SPRING:  
 NICKEL UNDERPLATE ALL OVER, MATING SURFACES PLATED TO MEET PERFORMANCE REQUIREMENTS OF TYCO ELECTRONICS SPECIFICATION 108-14008.  
 EYELET:  
 TIN .000100 THK MIN PER MIL-T-10727.
- 2. RECOMMENDED HOLE SIZES PLATED OR UNPLATED:  
 HAND OR MACHINE INSERTION; .075-.078.
- 3. TO INSURE PROPER SPRING TENSION DO NOT EXCEED A .002 DIFFERENCE IN PIN DIA WHEN CHANGING TO A SMALLER PIN.
- 4. RECOMMENDED PIN DIA .040.

645508-1  
 PART NUMBER

THIS DRAWING IS A CONTROLLED DOCUMENT.		DWN	R.TALLEY	2-19-90	Tyco Electronics Corporation Harrisburg, PA 17105-3608			
DIMENSIONS: INCHES		CHK	R.MILLER	2-20-90				
TOLERANCES UNLESS OTHERWISE SPECIFIED:		APVD	F.BOYD	2-20-90				
0 PLC ± - 1 PLC ± - 2 PLC ± - 3 PLC ± .008 4 PLC ± - ANGLES ± -		PRODUCT SPEC	NAME			ASSEMBLY, SOCKET, SPRING, MINIATURE		
MATERIAL: BERYLLIUM COPPER SPRING: QQ-C-533 EYELET: COPPER QQ-C-576		FINISH	WEIGHT		SCALE	CAGE CODE	DRAWING NO	RESTRICTED TO
		1		A2		00779	C=645508	-
CUSTOMER DRAWING		SCALE		SHEET		REV		
		NTS		1 OF 1		C1		

单击下面可查看定价，库存，交付和生命周期等信息

[>>TE Connectivity\(泰科\)](#)