

Figure 1

1. INTRODUCTION

This instruction sheet provides assembly and disassembly procedures for the AMP* Category 1 Automotive Plug Connector Assembly shown in Figure 1.

NOTE

All dimensions are in millimeters.

Reason for reissue of this sheet are provided in Section 6, REVISION SUMMARY.

2. DESCRIPTION

The plug assemblies are shipped as one piece, with the terminal position assurance (TPA) lock in the (open) position. The assembly consists of a housing, and a TPA lock.

Contacts are available only in strip form. 18 to 20 AWG contacts crimped with AMP manual Applicator 680124-2, or use 680125-2 for 22 AWG contacts. AMP Hand Tool 58587-1 is intended for limited prototyping and not production quantities.

3. ASSEMBLY PROCEDURES

Check to be sure the TPA lock is in the open, or as-shipped, position (see Figure 1). If the TPA lock is Closed, see Section 4 (Steps 1 and 2 only). Proceed as follows:

1. Insert a terminated contact by pushing it straight into the appropriate circuit cavity as far as it will go. See Figure 2.
2. Pull back lightly on the wire and contact to ensure the retention finger is holding the contact.

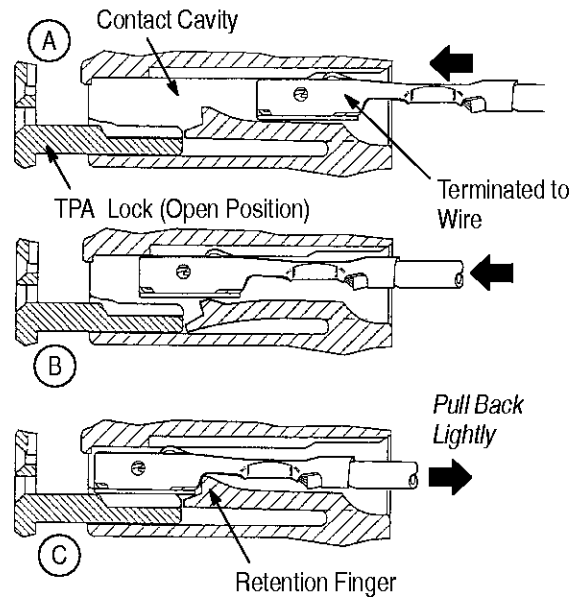

Figure 2

3. After all required contacts have been inserted, the TPA lock must be closed (see Figure 3). To close the TPA lock, push evenly across the TPA lock with a flat surface to secure all contacts in position. The TPA lock should be flush with plug housing.

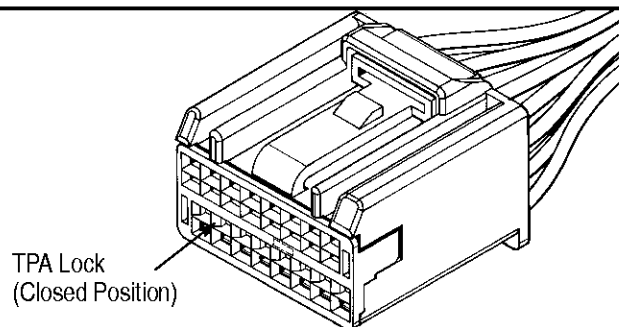

Figure 3

4. DISASSEMBLY PROCEDURES (Contact Removal)

Before removing contacts from the plug housing, the TPA lock must be completely removed. To remove the TPA lock and remove contacts proceed as follows:

1. Insert a 4 mm flat-blade screwdriver between the TPA latch tab and plug housing as shown in Figure 4.
2. Rotate the screwdriver **CLOCKWISE 90°**. Remove the screwdriver and repeat steps 1 and 2 on the opposite side of the plug housing.

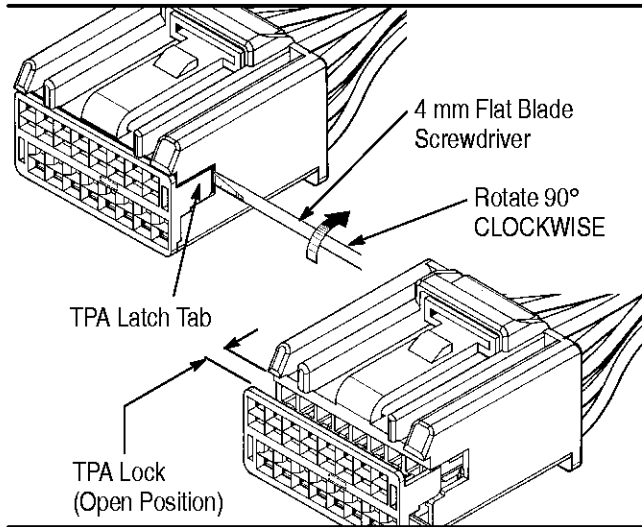

Figure 4

3. Remove TPA lock from the plug housing. Grasp the lock by the top and the bottom, and pull lightly until it is free from the plug housing, exposing the retention fingers. See Figure 5.

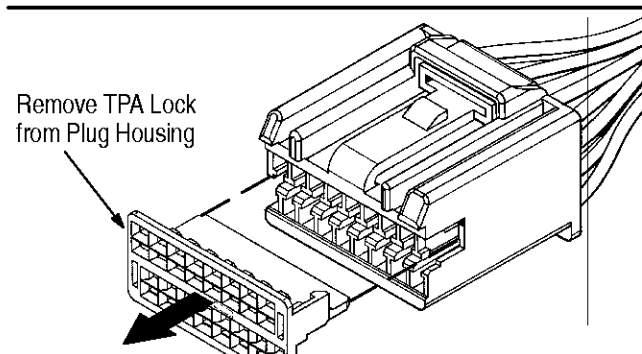

Figure 5

NOTE *The TPA lock must be removed from the plug assembly before removing contacts.*

4. Insert a 1 mm flat-blade screwdriver into the selected exposed contact cavity, as shown in Figure 6A.
5. Grasp the wire of the contact to be removed and push the contact forward until it stops.
6. Using 1 mm screwdriver, gently deflect retention finger (Figure 6B), then pull wire and contact from the plug housing.

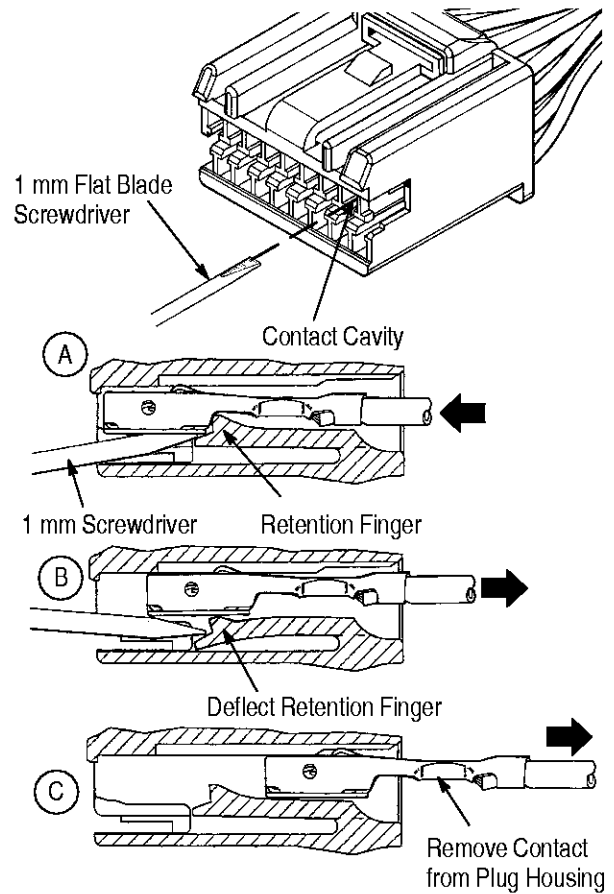

Figure 6

7. Follow steps 4 through 6 for remaining contacts.

NOTE *To re-assemble the plug assembly, the TPA lock must be installed and in the open position before insertion of terminated contacts.*

NOTE *To orient TPA for hybrid plug assemblies, align larger openings in plug for Category 2 receptacles.*

5. ADDITIONAL INFORMATION

For information on contact crimping, refer to the instructions packaged with the tooling. For inspection information on crimped contacts, refer to Application Specification 114-6063.

6. REVISION SUMMARY

Since the previous release of this instruction sheet, the following changes have been made:

Per EC 0990-0907-97

- Removed table from Figure 1
- Added note to Section 4, Step 7

单击下面可查看定价，库存，交付和生命周期等信息

[>>TE Connectivity\(泰科\)](#)