

| LOC | DIST | REV | DATE | BY | CHK | APPV |
|-----|------|-----|-----------|----|-----|------|
| GP | 00 | 1 | 20APR2009 | RG | RL | |
| | | 2 | 23APR2009 | RG | RL | |

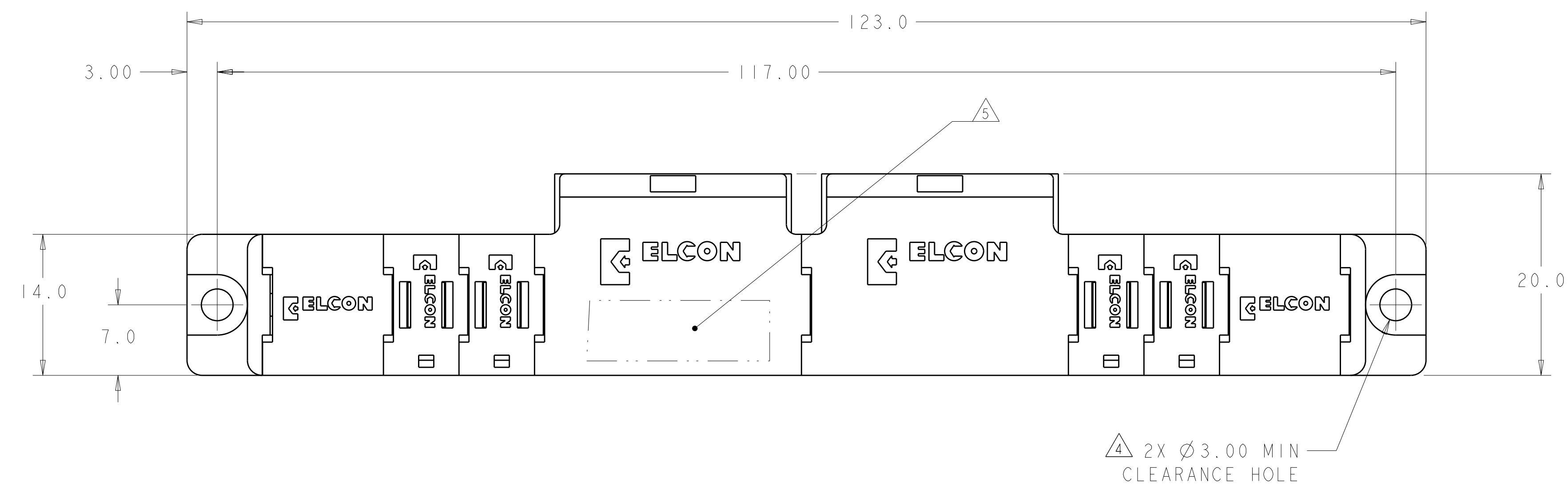

1. PART NUMBER CHANGES AND OR DESIGN CHANGES AFFECTING ITEM INTERCHANGEABILITY REQUIRE PRIOR TYCO ELECTRONICS APPROVAL AND AUTHORIZATION BY REVISION TO THIS DRAWING.

2 MATERIAL:
 INSULATORS - THERMOPLASTIC, GLASS REINFORCED,
 COLOR: BLACK, UL94V-0 FLAMMABILITY RATED.
 POWER CONTACTS - PHOSPHOR BRONZE ALLOY,
 COPPER ALLOY
 SOLDER SIGNAL PINS-BRASS ALLOY
 CROWN BAND-BERYLLIUM COPPER ALLOY

3 FINISH:
 CONTACTS - GOLD PLATE 0.76µm MIN. THK., OVER
 NICKEL 1.27µm MIN. THK
 SOLDER TAILS, TIN 3.05µm MIN. THK. OVER
 NICKEL 1.27µm MIN THK.

4 MOUNTING FLANGES ACCEPT M3 OR #4-40 SCREWS, (USER SUPPLIED)

5 ITEMS PROVIDED TO THIS SPECIFICATION TO BE PERMANENTLY IDENTIFIED PER THE FOLLOWING IDENTIFIER LABEL

TYCO ELECTRONICS P/N DATE CODE YEAR WEEK
 XXXXXXXX-X XXXX 1 1

6. CONNECTOR MATES WITH PN 2085239-1

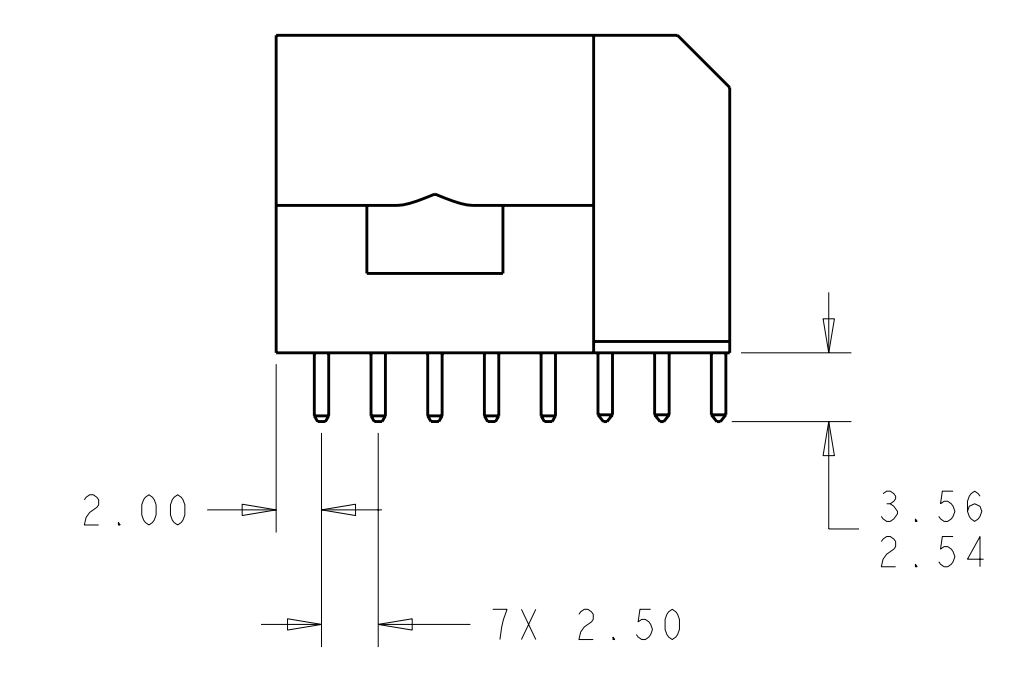
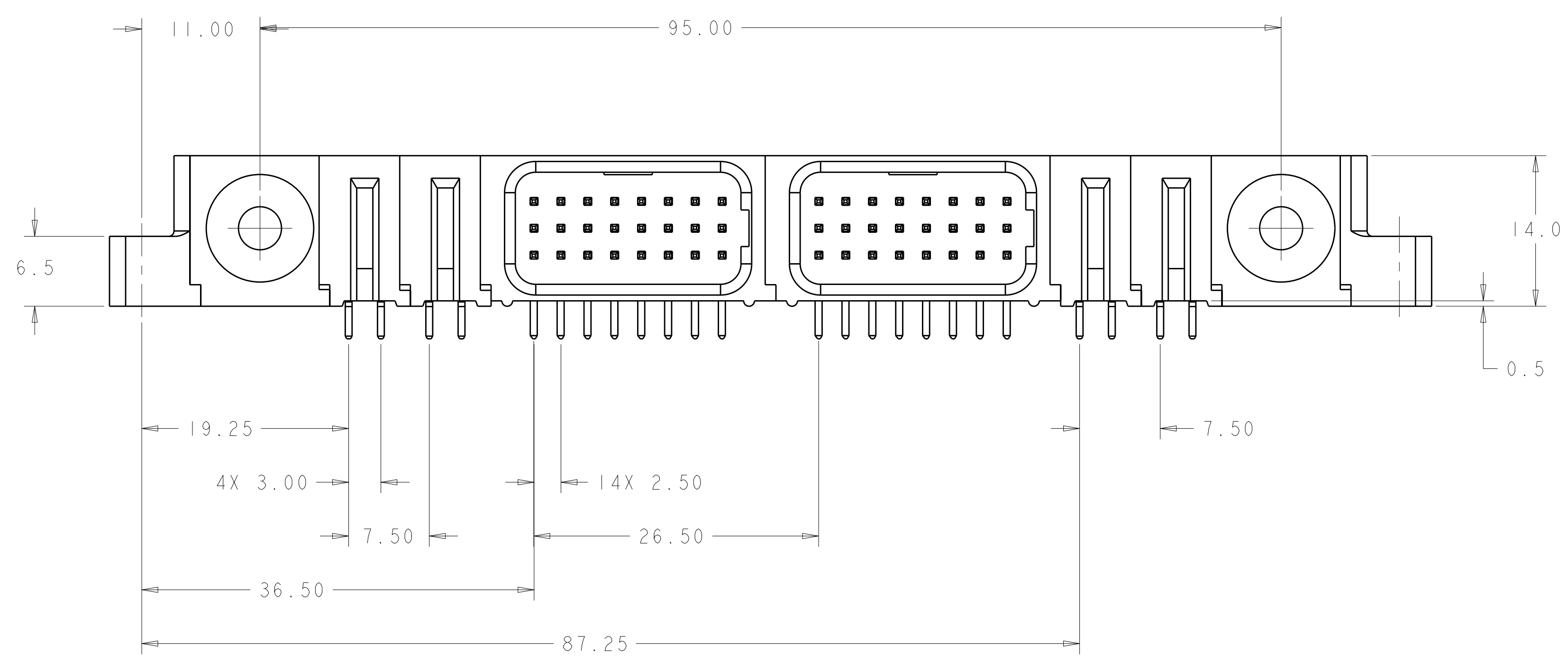

THIS PRINT IS
PRELIMINARY
 UNQUALIFIED PRODUCT
 CONTACT PRODUCT ENGINEERING
 BEFORE USING THIS PRINT

THIS DRAWING HAS BEEN
 REVIEWED AND APPROVED BY:
 SIGNED: _____
 DATE: _____
 THIS DRAWING IS A PRELIMINARY COPY AND CANNOT BE
 USED FOR MANUFACTURING UNTIL APPROVED BY CUSTOMER

| | |
|-------------|-------------|
| AS SHOWN | 2085238-1 |
| DESCRIPTION | PART NUMBER |

ELCON **FLATPAQ**

| | | | | | | | |
|-----------------------|--|-----------------------------------------------------------------------------------------------------------------|--|------------------------------------------------------------------------------------------------------------------------------------------------------------|--|----------------------------------------------------------------------------------------------------------------------------------------------------------------------------------|--|
| DIMENSIONS: mm | | TOLERANCES UNLESS OTHERWISE SPECIFIED: 9 PLC ±.5 5 PLC ±.25 4 PLC ±. ANGLES ±.5 FINISH 2 3 | | DWN: R. GRZYBOWSKI 20APRIL09 CHK: R. LONDON 20APRIL09 APPV: M. PERCHERIE 20APRIL09 PRODUCT SPEC APPLICATION SPEC WEIGHT CUSTOMER DRAWING | | Tyco Electronics Harrisburg, PA 17105-3608 NAME: PIN CONNECTOR, RIGHT ANGLE SOLDER TAILS SIZE: A100779 CAGE CODE: C=2085238 SCALE: 3:1 SHEET: 1 OF 3 REV: 2 | |
|-----------------------|--|-----------------------------------------------------------------------------------------------------------------|--|------------------------------------------------------------------------------------------------------------------------------------------------------------|--|----------------------------------------------------------------------------------------------------------------------------------------------------------------------------------|--|

| LOC | DIST | REV | DATE | BY | APPD |
|-----|------|-----|------|----|------|
| GP | 00 | | | | |

| REVISIONS | | | |
|-----------|------|----|------|
| REV | DATE | BY | APPD |
| - | - | - | - |
| - | - | - | - |

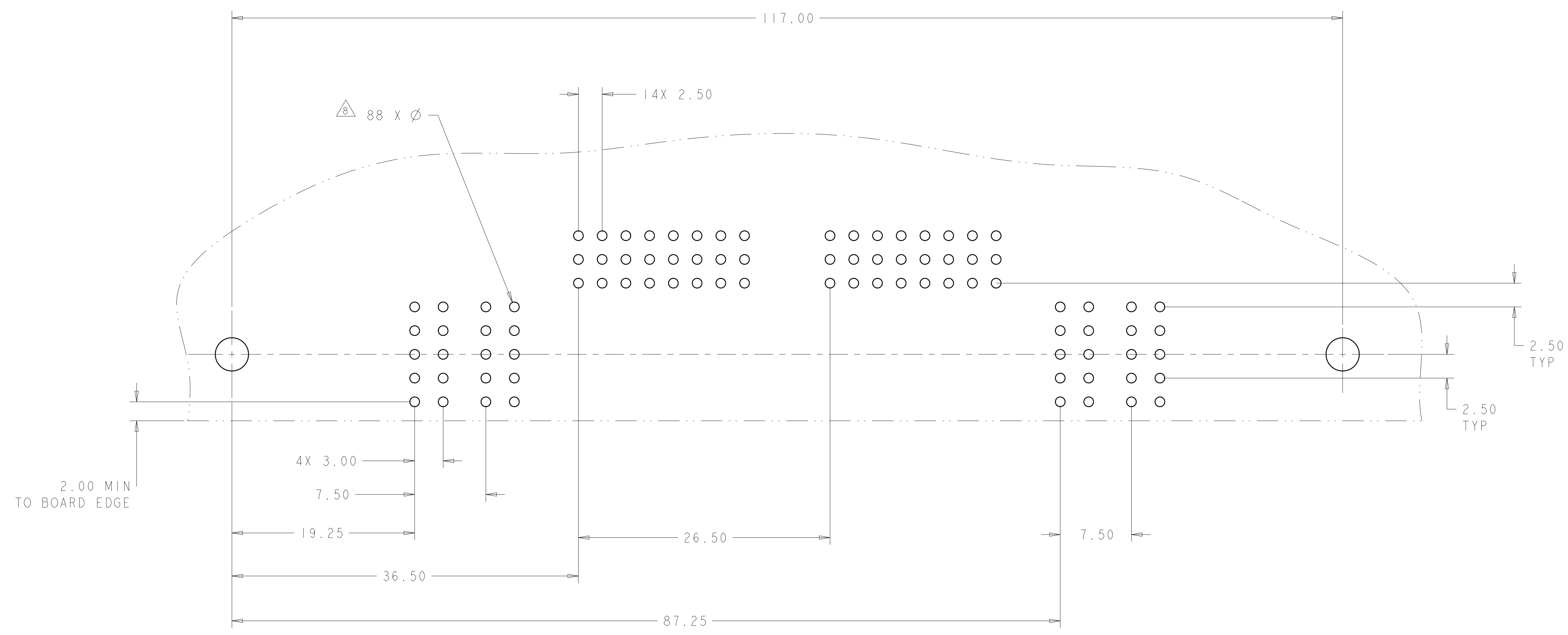

PRINTED CIRCUIT LAYOUT
 COMPONENT SIDE

THIS PRINT IS
PRELIMINARY
 UNQUALIFIED PRODUCT
 CONTACT PRODUCT ENGINEERING
 BEFORE USING THIS PRINT

| CONNECTOR | EQUIVALENT CATALOG MODULE # | MODULE QTY | CONTACT QTY | SIZE NO. | MATING PIN | MAX. CURRENT (PER CONTACT) | CONTACT SPACING | VOLTAGE RATING |
|-----------|-----------------------------|------------|-------------|----------|--------------------------|----------------------------|-----------------|----------------|
| PIN | FP104 | 4 | 4 | 8 | 1.25 X 7.00 | 35 amps | 7.5 | 250 |
| | FP302 | 2 | 48 | 22 | .64 SQ. | 3 amps | 2.50 | 125 VOLTS |
| | FP506 | 2 | - | - | RIGHT ANGLE GUIDE SOCKET | | | |
| | FP500 | 1 | - | - | LEFT MOUNTING FLANGE | | | |
| | FP501 | 1 | - | - | RIGHT MOUNTING FLANGE | | | |

ELCON FLATPAQ

| | | | | | | | |
|-----------------------|--|----------------------------------------------------------------------------------------------------------------------------------|--|-----------------------------------------------------------------------------------------------------------------------------------------------------------------|--|-----------------------------------------------------------------------------------------------------------------------------------------------|--|
| DIMENSIONS: mm | | TOLERANCES UNLESS OTHERWISE SPECIFIED: 9 PLC ±.5 1 PLC ±.5 2 PLC ±.25 3 PLC ±.5 4 PLC ±.5 ANGLES ±.5 FINISH | | DWN R. GRZYBOWSKI 20APRIL09 CHK R. LONDON 20APRIL09 APVD M. PERCHERIE 20APRIL09 NAME PRODUCT SPEC APPLICATION SPEC WEIGHT CUSTOMER DRAWING | | Tyco Electronics Harrisburg, PA 17105-3608 SIZE CAGE CODE DRAWING NO. RESTRICTED TO A100779C-2085238 SCALE 3:1 SHEET 2 OF 3 REV 2 | |
|-----------------------|--|----------------------------------------------------------------------------------------------------------------------------------|--|-----------------------------------------------------------------------------------------------------------------------------------------------------------------|--|-----------------------------------------------------------------------------------------------------------------------------------------------|--|

| LOC | DIST | REVISIONS | | | | | |
|-----|------|-----------|-----|-------------|------|-----|------|
| GP | 00 | P | LTB | DESCRIPTION | DATE | DWN | APVD |
| | | - | - | SEE SHEET 1 | - | - | - |
| | | | | | | | |
| | | | | | | | |

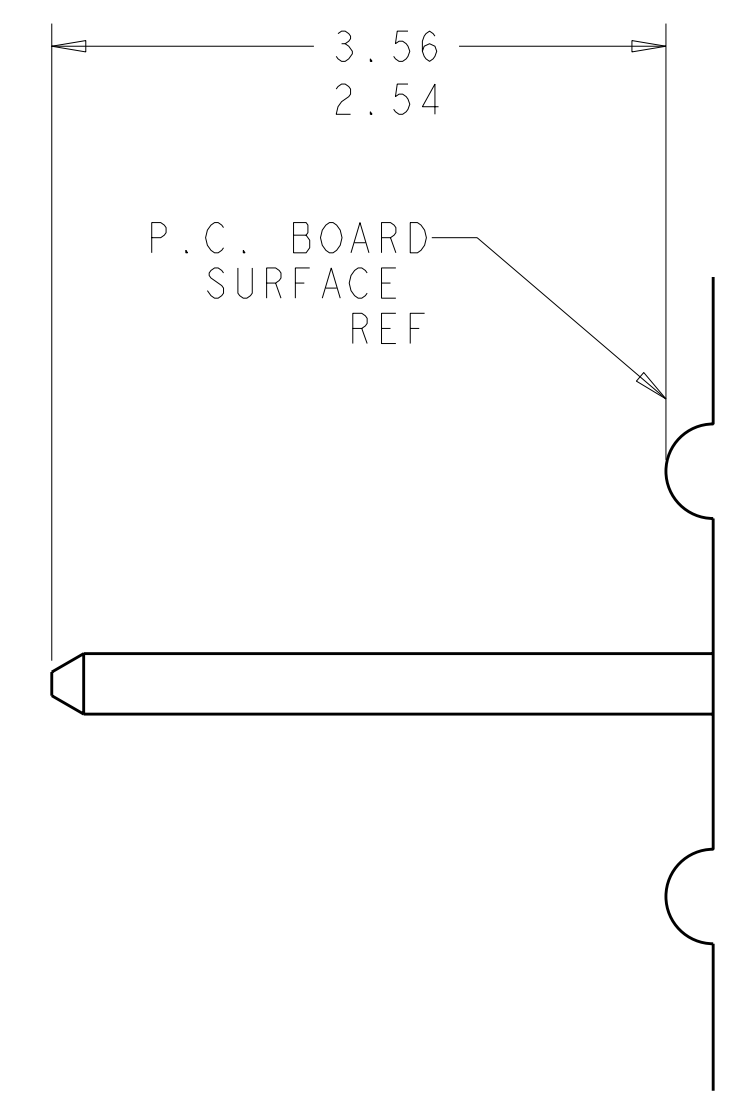

7. SOLDER PIN DETAIL
SCALE 10:1

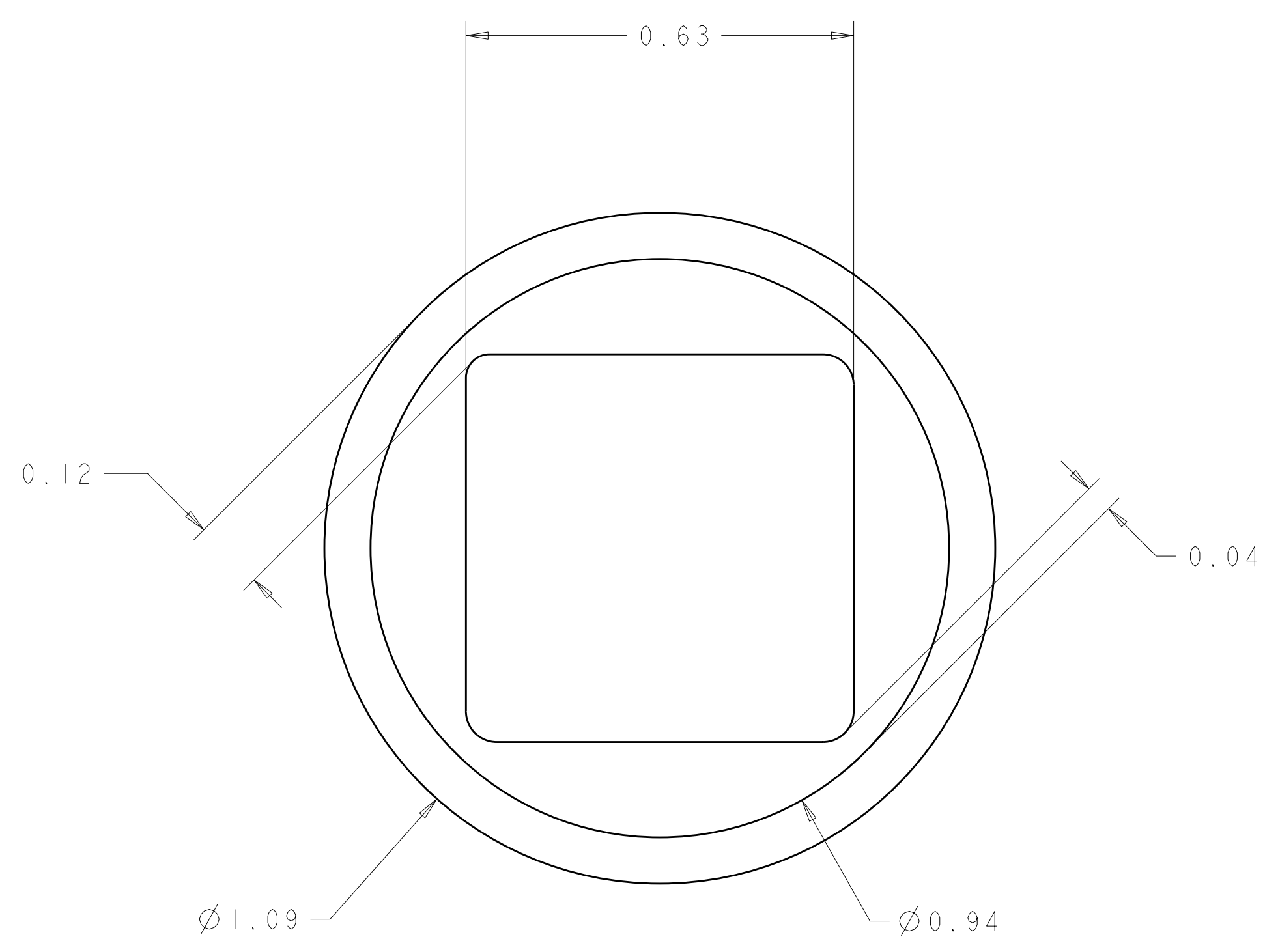

8 SOLDER TERMINATION AREA
 SCALE 40:1
 RECOMMENDED PRINTED CIRCUIT SOLDER HOLE
 FINISHED HOLE: Ø1.02 ±.08
 DRILLED HOLE: Ø1.15 ±.013
 COPPER PLATE: .025 MIN.
 TIN PLATE: .008 MIN. (PER SURFACE)

THIS PRINT IS
PRELIMINARY
 UNQUALIFIED PRODUCT
 CONTACT PRODUCT ENGINEERING
 BEFORE USING THIS PRINT

ELCON FLATPAQ

| | | | |
|----------------------------------------------------------------------------------------------------------------------------|-----------------------------------------------------------------------------------------------------------------------------------|---------------------------------------------------------------------------------------|-------------------------------------------------------------------------------------------------------------------------------------|
| <small>THIS DRAWING IS UNPUBLISHED. RELEASED FOR PUBLICATION BY TYCO ELECTRONICS CORPORATION. ALL RIGHTS RESERVED.</small> | | DWN R. GRZYBOWSKI 20APRIL09 CHK R. LONDON 20APRIL09 APVD M. PERCHERIE 20APRIL09 | Tyco Electronics Harrisburg, PA 17105-3608 |
| DIMENSIONS: mm | TOLERANCES UNLESS OTHERWISE SPECIFIED: 9 PLC ±.5 1 PLC ±.5 2 PLC ±.25 3 PLC ±.25 4 PLC ±.5 ANGLES ±.5 FINISH | NAME PRODUCT SPEC APPLICATION SPEC WEIGHT CUSTOMER DRAWING | NAME PIN CONNECTOR, RIGHT ANGLE SOLDER TAILS SIZE CAGE CODE DRAWING NO A100779C-2085238 SCALE 3:1 SHEET 3 OF 3 REV 2 |

单击下面可查看定价，库存，交付和生命周期等信息

[>>TE Connectivity\(泰科\)](#)