

- 1 AMP TRADEMARK LOCATED IN APPROX AREA SHOWN.
- 2 STANDOFFS: POSN 10 (8) STANDOFFS AS SHOWN.
 POSN 14 (11) STANDOFFS, 3 PER DIAGONAL ROW.
 POSN 18 (14) STANDOFFS, 3 PER DIAGONAL ROW.
 POSN 22 (17) STANDOFFS, 3 PER DIAGONAL ROW.
 POSN 26 (20) STANDOFFS, 3 PER DIAGONAL ROW.
 POSN 30 (23) STANDOFFS, 3 PER DIAGONAL ROW.
 POSN 34 (26) STANDOFFS, 3 PER DIAGONAL ROW.
 POSN 38 (29) STANDOFFS, 3 PER DIAGONAL ROW.
 POSN 42 (32) STANDOFFS, 3 PER DIAGONAL ROW.
 POSN 46 (35) STANDOFFS, 3 PER DIAGONAL ROW.
 POSN 50 (38) STANDOFFS, 3 PER DIAGONAL ROW.
 POSN 54 (41) STANDOFFS, 3 PER DIAGONAL ROW.
 POSN 58 (44) STANDOFFS, 3 PER DIAGONAL ROW.
- 3 FINISH: BRIGHT TIN-LEAD .000100-.000200 THK OVER NICKEL .000050 MIN THK.
- 4 HEIGHT AFTER TERMINATION IS .238 REF.
- 5 FINISH: BRIGHT TIN .000100-.000200 THK OVER NICKEL .000050 MIN THK.

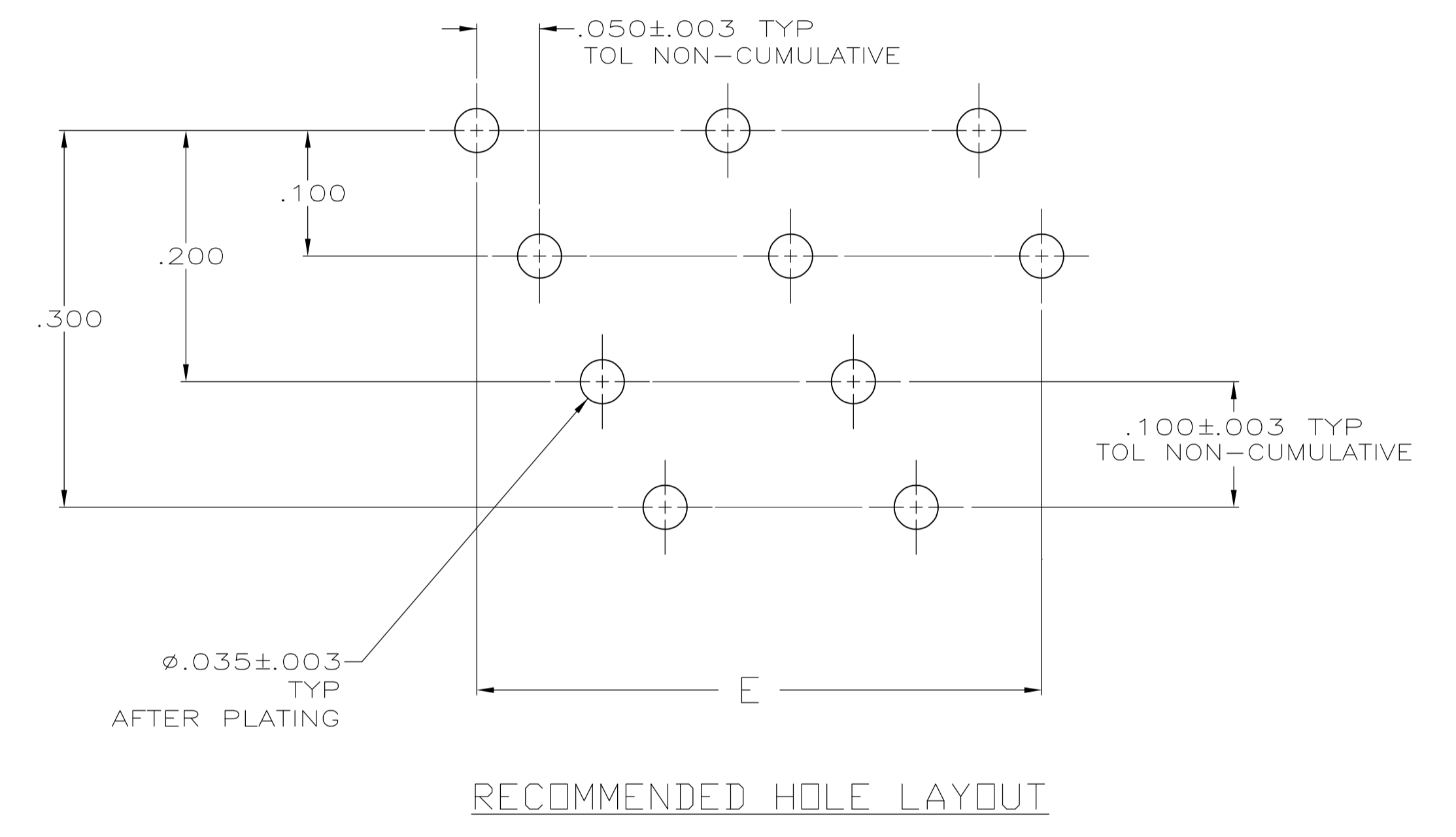

	5	4	3	2	1	50	49	PART NUMBER
	2.450	2.450	2.774	2.450	2.450	49	50	6-111037-1
	1.650	1.650	1.974	1.650	1.650	33	34	5-111037-7
	1.450	1.450	1.774	1.450	1.450	29	30	5-111037-6
	1.250	1.250	1.574	1.250	1.250	25	26	5-111037-5
	.650	.650	.974	.650	.650	13	14	5-111037-2
	.450	.450	.774	.450	.450	9	10	5-111037-1
OBSOLETE	2.850	2.850	3.174	2.850	2.850	57	58	1-111037-3
OBSOLETE	2.650	2.650	2.974	2.650	2.650	53	54	1-111037-2
	2.450	2.450	2.774	2.450	2.450	49	50	1-111037-1
OBSOLETE	2.250	2.250	2.574	2.250	2.250	45	46	1-111037-0
OBSOLETE	2.050	2.050	2.374	2.050	2.050	41	42	111037-9
OBSOLETE	1.850	1.850	2.174	1.850	1.850	37	38	111037-8
	1.650	1.650	1.974	1.650	1.650	33	34	111037-7
	1.450	1.450	1.774	1.450	1.450	29	30	111037-6
	1.250	1.250	1.574	1.250	1.250	25	26	111037-5
OBSOLETE	1.050	1.050	1.374	1.050	1.050	21	22	111037-4
OBSOLETE	.850	.850	1.174	.850	.850	17	18	111037-3
	.650	.650	.974	.650	.650	13	14	111037-2
	.450	.450	.774	.450	.450	9	10	111037-1
FINISH	F	E	D	C	B	A	NO OF POSN	PART NUMBER

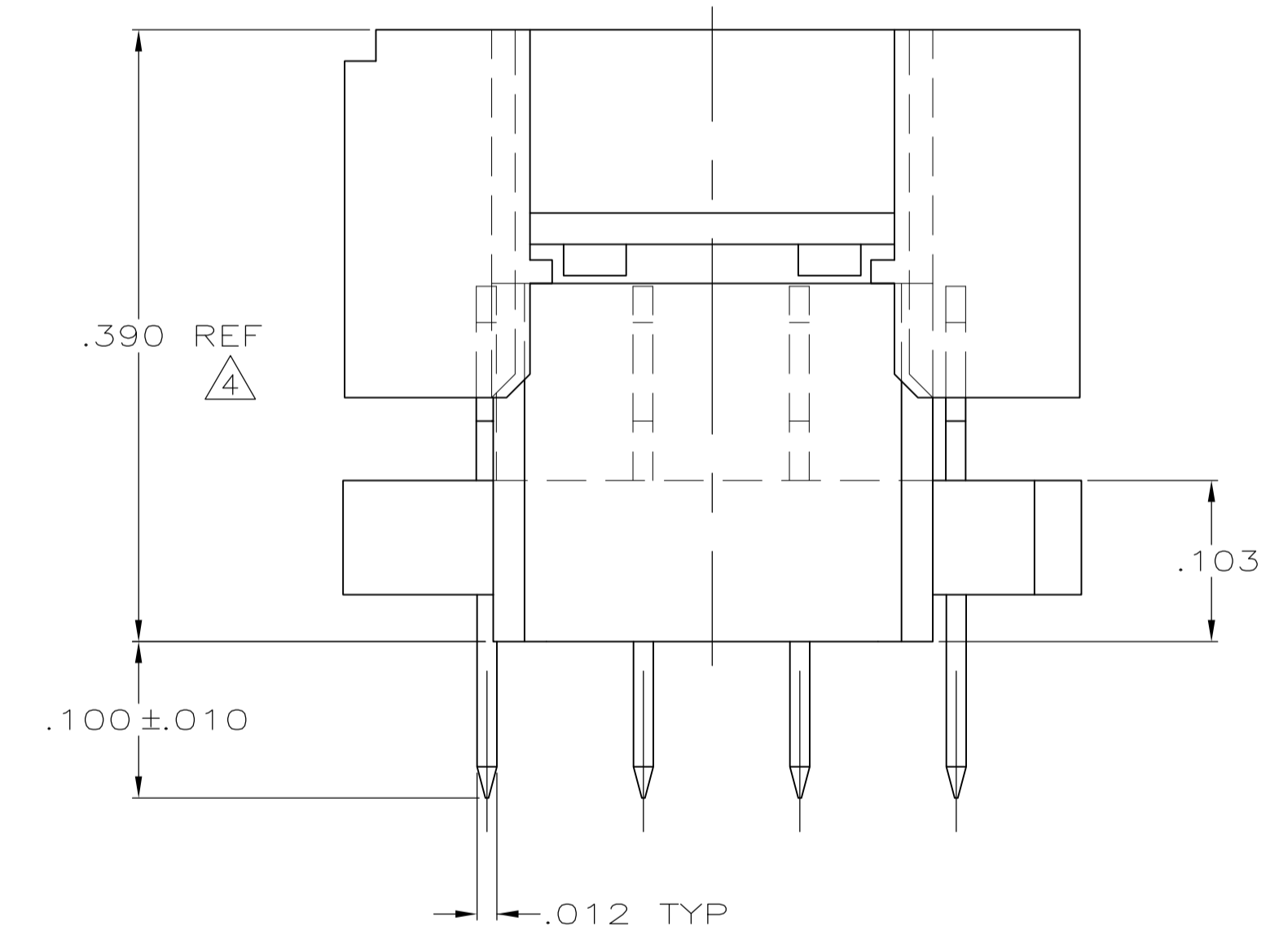
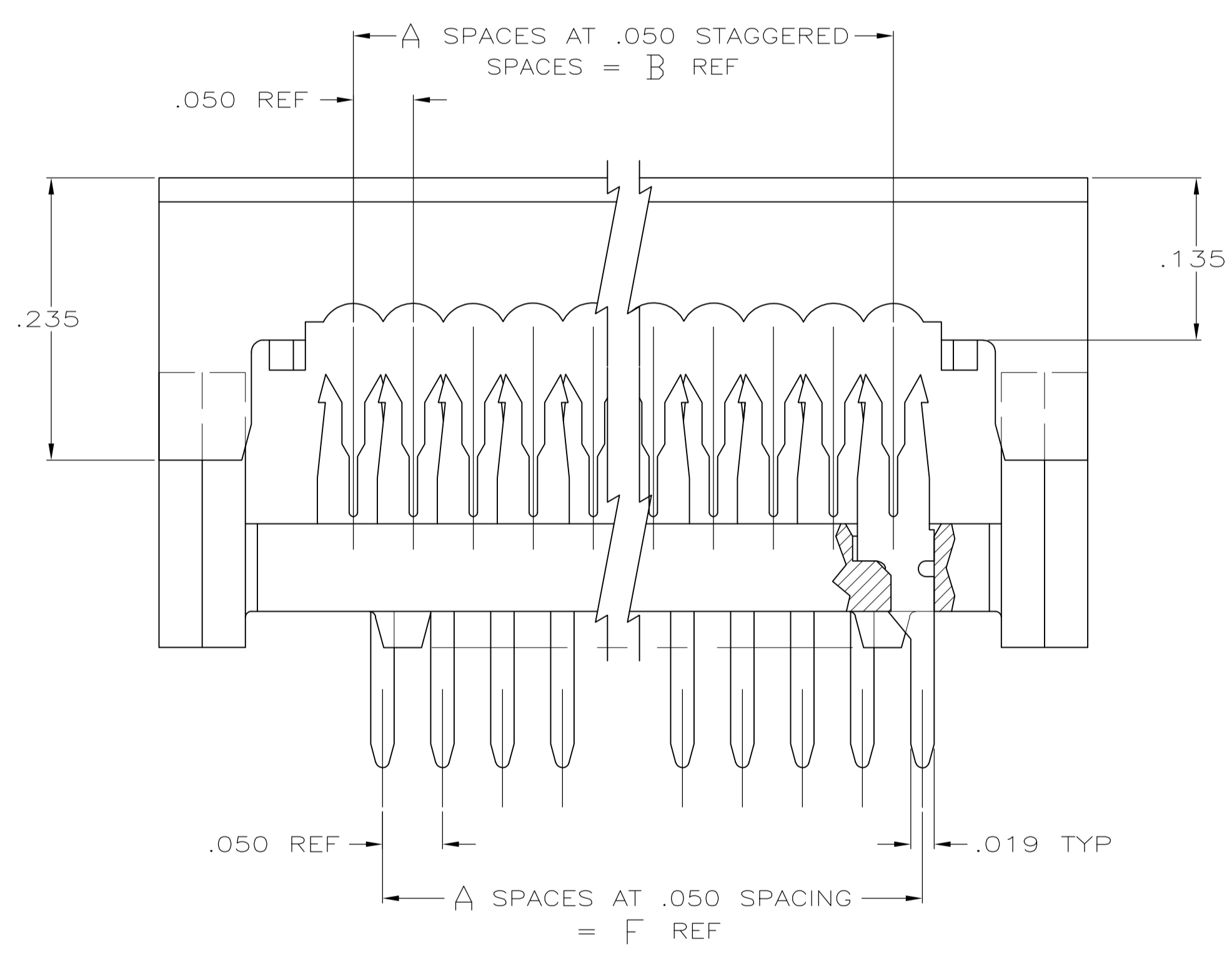
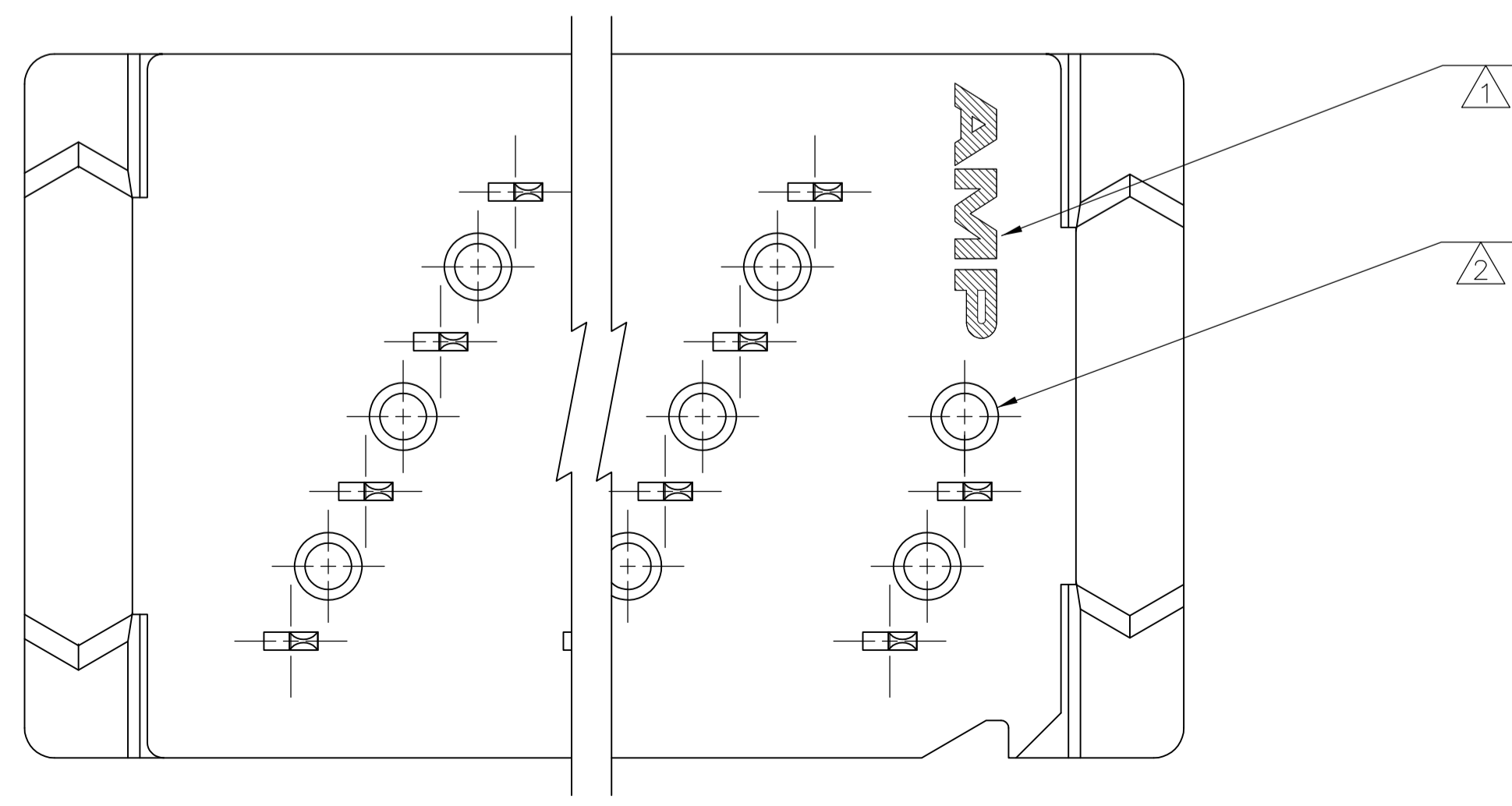

THIS DRAWING IS A CONTROLLED DOCUMENT. DIN J. PEACHEY 05-MAR-86
 CHK M. SCULLY 23-MAY-86
 APPV D. HOFFMAN 23-MAY-86 NAME

STE TE Connectivity

KIT, AMP-LATCH PADDLEBOARD
 PREASSEMBLED, .100 LONG POSTS
 SHORT END, FULL TIN PLATED CONTACTS

SIZE CAGE CODE DRAWING NO. RESTRICTED TO
 A1 00779 C=111037

MATERIAL MILDED PARTS: 94V-0 RATED THERMOPLASTIC, COLOR BLACK CONTACTS PH BRZ PER QS-B-750 FINISH CONTACTS

WEIGHT - A1 00779 C=111037 SCALE 10:1 SHEET 1 OF 1 REV J

单击下面可查看定价，库存，交付和生命周期等信息

[>>TE Connectivity\(泰科\)](#)