

4

3

2

1

THIS DRAWING IS UNPUBLISHED. RELEASED FOR PUBLICATION
 © COPYRIGHT - By - ALL RIGHTS RESERVED.

REVISIONS					
P	LTR	DESCRIPTION	DATE	DWN	APVD
	C1	REVISED PER ECO-15-006978	06JUN2015	NK	MM
	C2	REVISED PER ECO-17-008806	20FEB2018	RS	DR

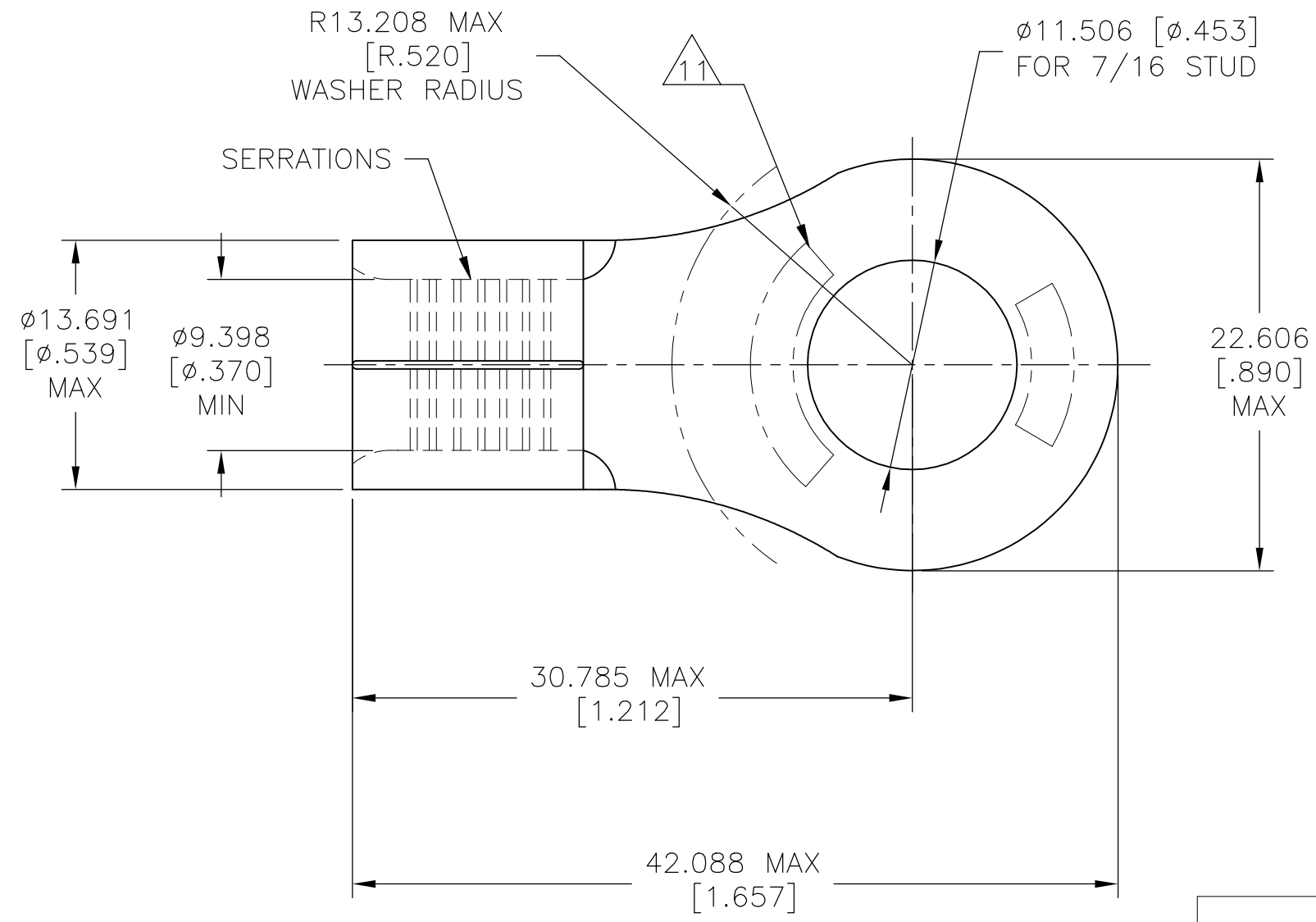

- 1 BODY MATERIAL THICKNESS IS 1.778±0.050[.070±.002].
- 2 COPPER PER ASTM B152, ANNEALED.
- 3 TIN PLATE 0.00254[.000100] MIN EXT THK PER ASTM B545.
- 4 NOTE DELETED
- 5 MEETS MS20659-148, CLASS 2
- 6 NICKEL PLATE 0.00762[0.000300] MIN EXT THK PER QQ-N-290.
- 7 26.7-42.4 sq-mm [52,600-83,700] CIR MILS, SOLID OR STRANDED.
- 8 UL LISTED, FILE E13288.
- 9 CSA CERTIFIED, FILE LR7189.
- 10 PRELIMINARY - NOT FOR PRODUCTION.
- 11 STAMP AMP 2W* 60-75 APPROX AS SHOWN
- 12 UL 486 A-B OR SAE AS 7928

-	343°C MAX	50	LOOSE PIECE	6	320741-1
5 8 9	170°C MAX	50	LOOSE PIECE	3	320741
APPROVALS	TEMPERATURE	QTY	PACKAGING TYPE	FINISH	PART NO

THIS DRAWING IS A CONTROLLED DOCUMENT.		DWN jr ruth 03OCT03	STE TE Connectivity Ltd.		
DIMENSIONS: mm [INCHES]		CHK MJ SPICER 03OCT03			
TOLERANCES UNLESS OTHERWISE SPECIFIED:		APVD MJ SPICER 03OCT03	NAME TERMINAL, SOLISTRAND, RING TONGUE, WIRE SIZE : 2 AWG		
0 PLC ± - 1 PLC ± - 2 PLC ± - 3 PLC ± 0.127[.005] 4 PLC ± - ANGLES ± 5°		PRODUCT SPEC 12			
MATERIAL 2	FINISH SEE TABLE	APPLICATION SPEC -	SIZE A3	CAGE CODE 00779	DRAWING NO C-320741
CUSTOMER DRAWING			RESTRICTED TO -	SCALE 3:1	SHEET 1 OF 1
			REV C2		

单击下面可查看定价，库存，交付和生命周期等信息

[>>TE Connectivity\(泰科\)](#)