

THIS DRAWING IS UNPUBLISHED. RELEASED FOR PUBLICATION 20  
 © COPYRIGHT 20 ALL RIGHTS RESERVED.

LOC		DIST		REVISIONS			
P	LTR	DESCRIPTION	DATE	DWN	APVD		
		B11	REVISED PER ECO-11-005027	18MAY2011	RK	HMR	

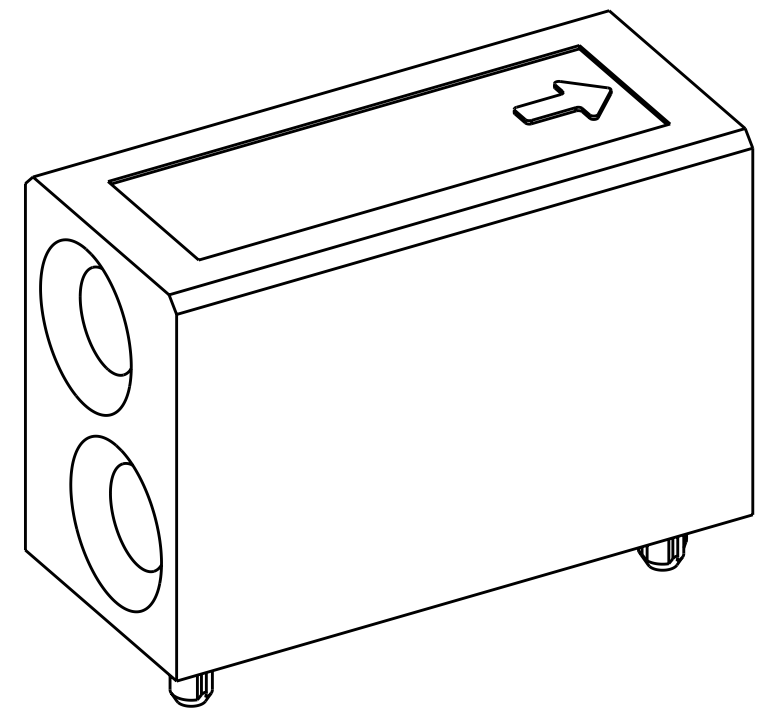
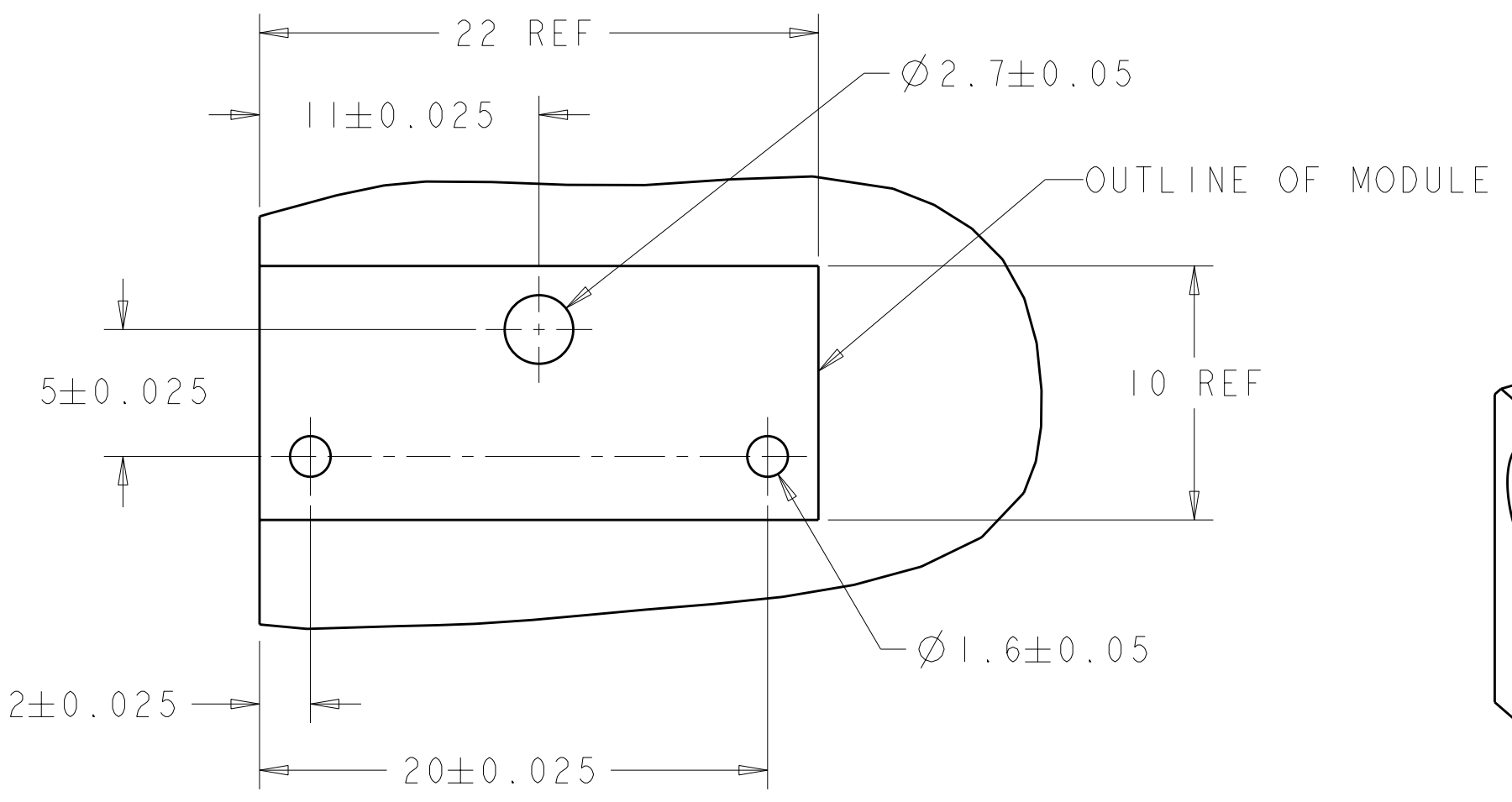

- NOTES:
- RECOMMENDED MOUNTING HARDWARE - M2.5 X 0.45 SCREW, 7.0MM LONG UP TO 2.9 MM THICK PCB, 8.0MM LONG FOR 3.0 TO 4.0 MM THICK PCB, 10.0MM FOR 4.1 TO 6.0MM THICK PCB, 12.0MM FOR 6.1 TO 8.0MM THICK PCB. (HARDWARE NOT SUPPLIED WITH PART NUMBER)
  - ENHANCED VERSION AVAILABLE FOR NEB'S DROP TEST. REFERENCE DRAWING 1469959.

PCB LAYOUT

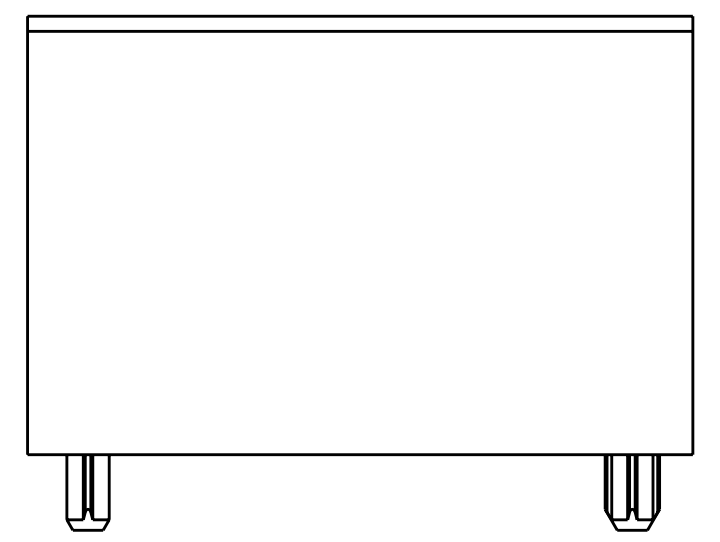
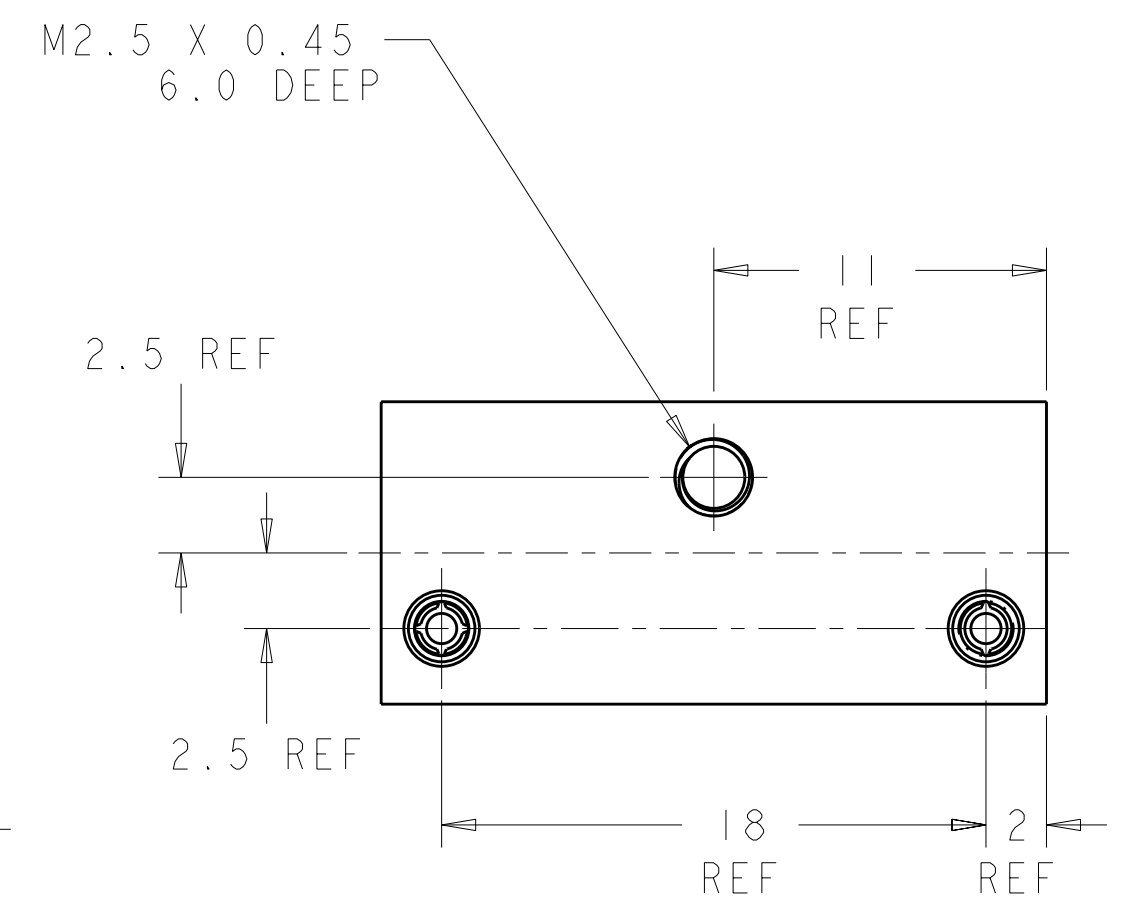
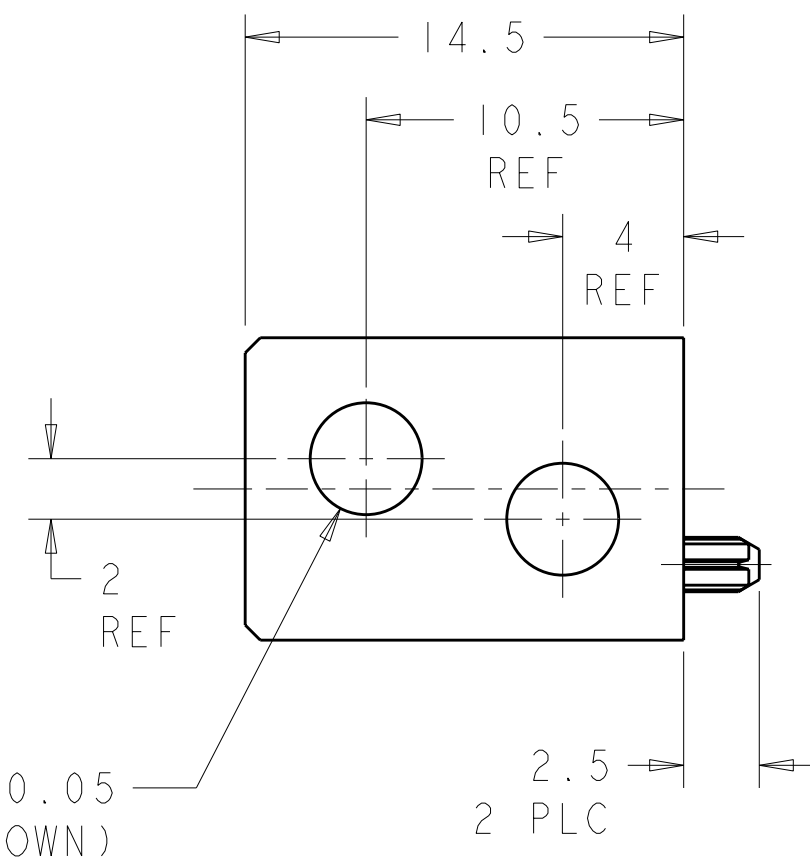
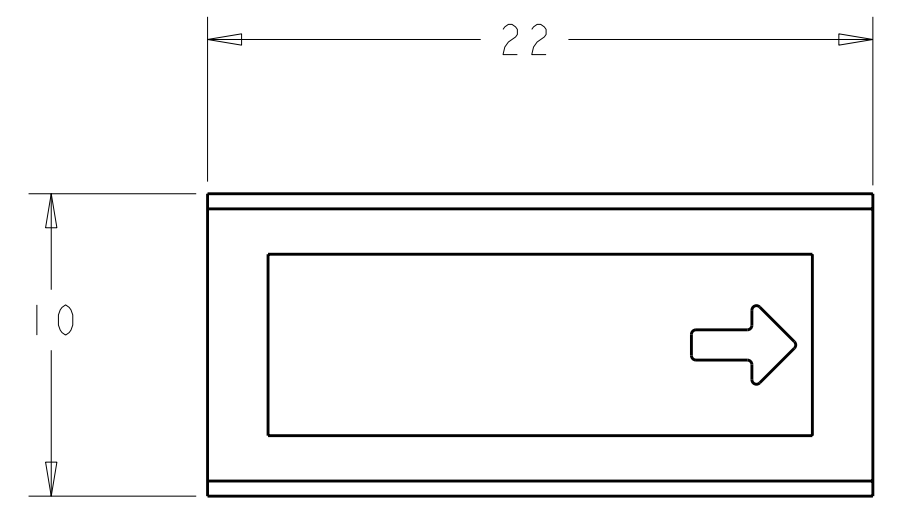
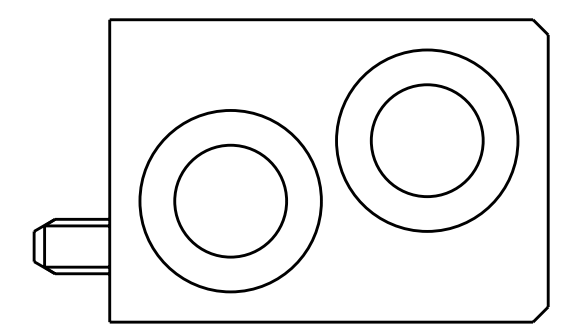

1469374-1  
PART NUMBER

THIS DRAWING IS A CONTROLLED DOCUMENT.		DWN D. SZCZESNY 17DEC02	TE Connectivity	
DIMENSIONS: mm		CHK R. PATTERSON 14SEP04		
TOLERANCES UNLESS OTHERWISE SPECIFIED:		APVD R. PATTERSON 14SEP04	NAME ATCA GUIDE MODULE (REAR TRANSITION MODULE - rKI)	
0 PLC ±0.2 1 PLC ±0.5 2 PLC ±0.13 3 PLC ±0.013 4 PLC ±0.0001 ANGLES ±0.5 FINISH		PRODUCT SPEC -	SIZE A200779	DRAWING NO C-1469374
MATERIAL ZAMAK 3		APPLICATION SPEC -	WEIGHT -	RESTRICTED TO -
		CUSTOMER DRAWING	SCALE 4:1	SHEET 1 OF 1 REV B1

单击下面可查看定价，库存，交付和生命周期等信息

[>>TE Connectivity\(泰科\)](#)