

THIS DRAWING IS UNPUBLISHED. RELEASED FOR PUBLICATION
 © COPYRIGHT - By - ALL RIGHTS RESERVED.

LOC	DIST	REVISIONS			
P	LTR	DESCRIPTION	DATE	DWN	APVD
AF	50	C	REVISED PER ECR-18-009392	28MAR2019	BDA SV

- 1 CONTINUOUS STRIP ON REELS WITH TERMINALS LOCATED ON 5.59±0.08 [.220±.003] CENTERS
- 2 SLOT ACCEPTS A 0.43-0.51mm [#25.5-#24] AWG COPPER MAGNET WIRE.
- 3 MATES WITH STANDARD MAG-MATE STYLED POKE-IN TAB TERMINAL.
- 4 WHEN FREE STATE IS COMPRESSED TO 3.23 [.127] DIMENSION GAP BETWEEN SPRING AND CARRIER IS TO BE 0.30 [.012] MAX.
- 5 0.0010 [.000040] MIN TIN
- 6 ANTI-FRETTING LUBRICANT APPLIED.
- 7 0.00382 [.000150] MIN SILVER PLATE OVER 0.00127 [.000050] MIN NICKEL UNDERPLATE.
- 8 PRELIMINARY - NOT FOR PRODUCTION.

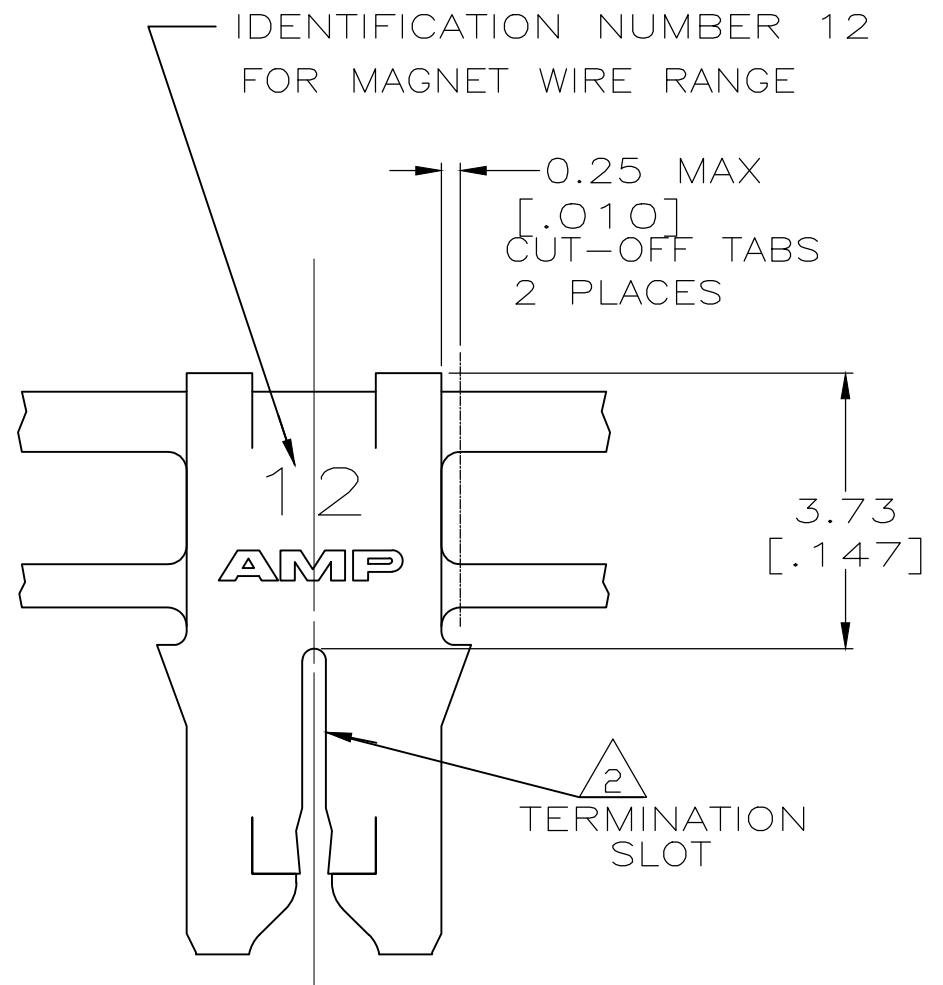
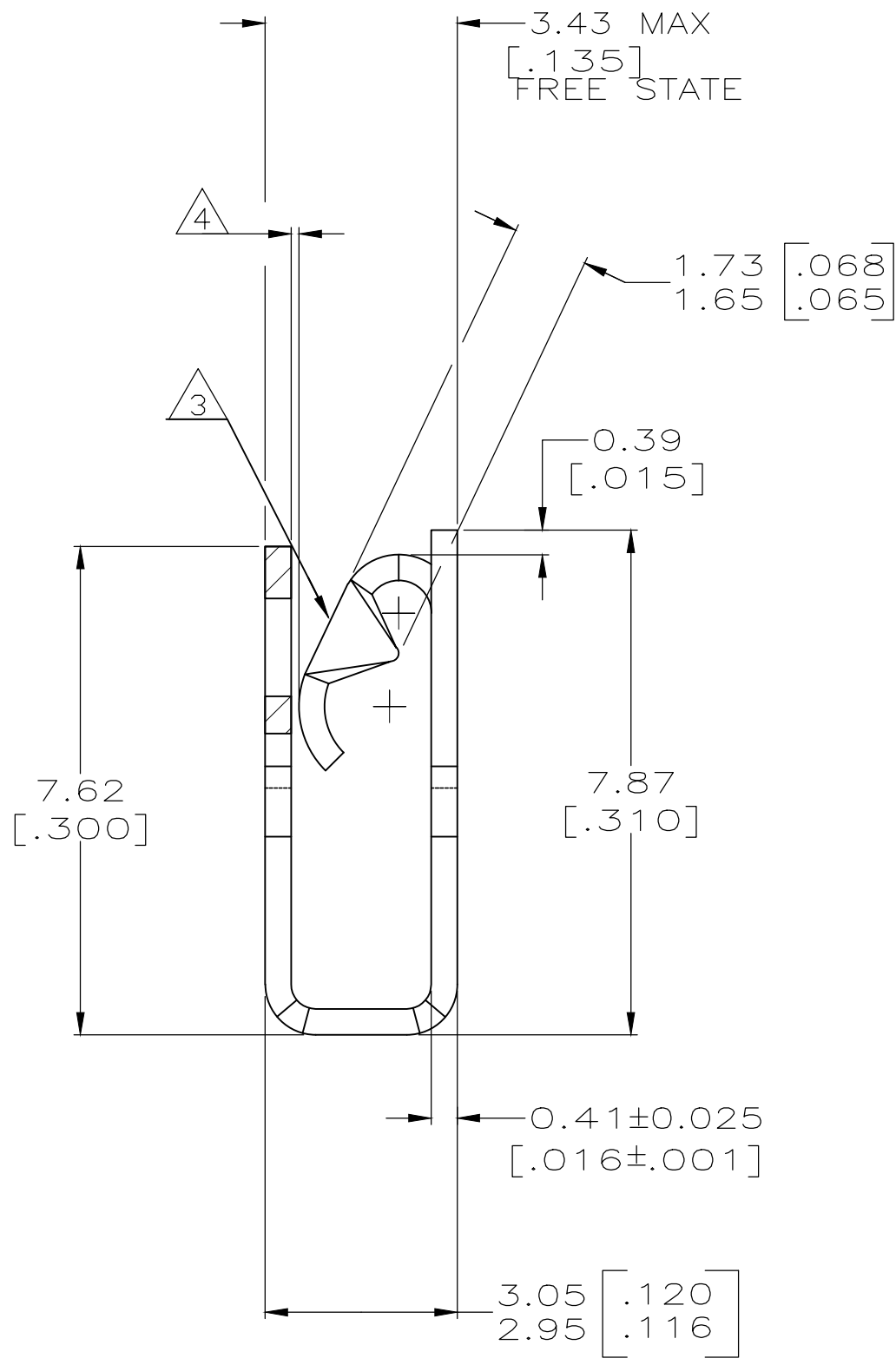
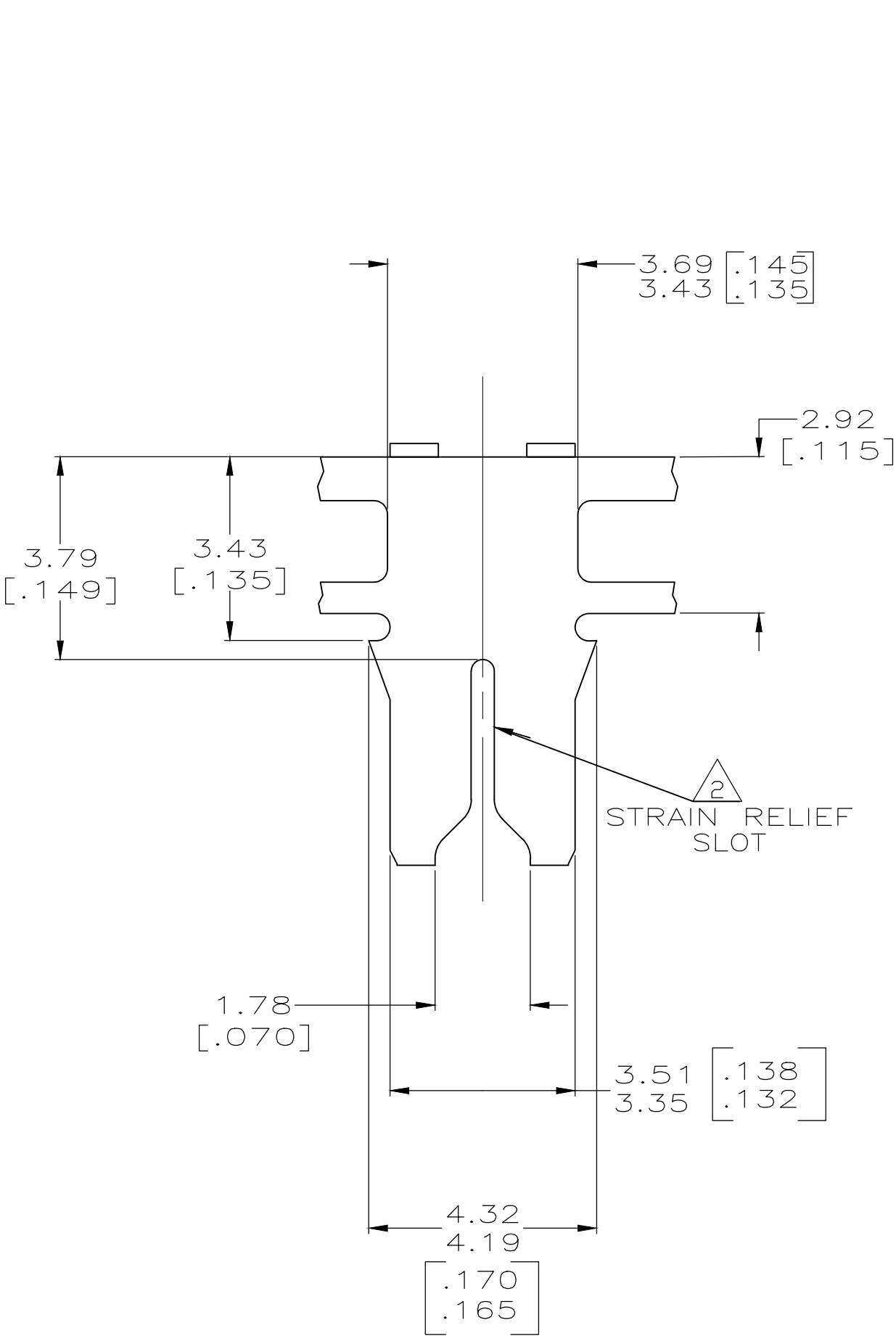
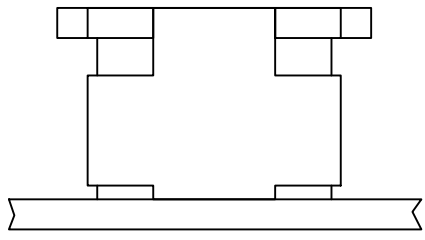

FINISH	MATERIAL	PART NUMBER
7	4M BRASS	8 1217690-4
5 6	H04 PHOSPHOR BRONZE	8 1217690-3
5 6	4M BRASS	8 1217690-2
5	4M BRASS	1217690-1

THIS DRAWING IS A CONTROLLED DOCUMENT.

DWN	15OCT2001	MICHAEL S. FEHER		TE Connectivity		
CHK	17OCT2001	KURT A. RANDOLPH		SPECIAL LEAF CONTACT, 300 SERIES MAG-MATE™		
APVD	17OCT2001	KURT A. RANDOLPH		SIZE	CAGE CODE	DRAWING NO
PRODUCT SPEC	108-2012	114-2046		A2	00779	C=1217690
APPLICATION SPEC	114-2046	WEIGHT	CUSTOMER DRAWING		RESTRICTED TO	
MATERIAL	FINISH	SEE TABLE	SCALE	10:1	SHEET 1 OF 1	
SEE TABLE		SEE TABLE	REV	C		

单击下面可查看定价，库存，交付和生命周期等信息

[>>TE Connectivity\(泰科\)](#)