

THIS DRAWING IS UNPUBLISHED. RELEASED FOR PUBLICATION  
 © COPYRIGHT - BY TYCO ELECTRONICS CORPORATION. ALL RIGHTS RESERVED.

LOC	DIST	REVISIONS					
GP	00	P	LTR	DESCRIPTION	DATE	DWN	APVD
			0	RELEASED AS PER EC OS13-0226-05	09AUG05	BL	JG

- ① ZINC PLATED .000200-.000400 THICK, YELLOW CHROMATE COATING.
- ② ZINC PLATED .000200-.000400 THICK, CLEAR CHROMATIC COATING.
- ③ UNDERCUT MAY OR MAY NOT BE PRESENT IN THIS AREA.

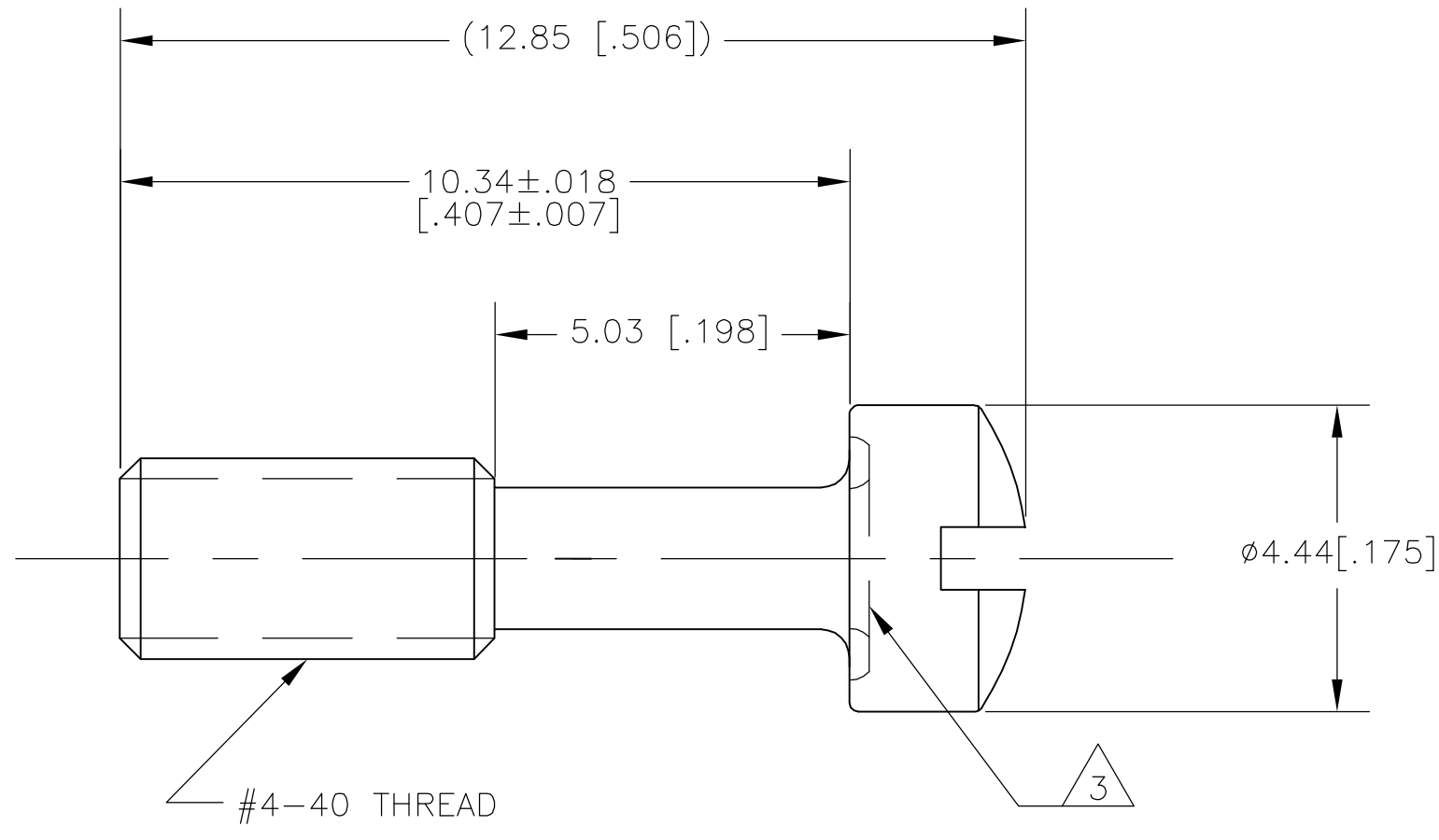

②	5747971-3
①	5747971-2
FINISH	PART NUMBER

THIS DRAWING IS A CONTROLLED DOCUMENT.		DWN B. LATTUCA	09AUG05	Tyco Electronics Corporation Harrisburg, Pa 17105-3608			
DIMENSIONS: MM [INCHES]		CHK C. ROHDE	09AUG05				
TOLERANCES UNLESS OTHERWISE SPECIFIED:		APVD M. WALMSLEY	09AUG05	NAME MOUNTING SCREW, #4-40, AMPLIMITE			
0 PLC ± - 1 PLC ± - 2 PLC ± - 3 PLC ± .005 4 PLC ± - ANGLES ± 1°		PRODUCT SPEC -		APPLICATION SPEC -			
MATERIAL CARBON STEEL	FINISH SEE TABLE	WEIGHT -		SIZE A3	CAGE CODE 00779	DRAWING NO C-5747971	RESTRICTED TO -
CUSTOMER DRAWING				SCALE 10:1	SHEET 1 OF 1	REV 0	

单击下面可查看定价，库存，交付和生命周期等信息

[>>TE Connectivity\(泰科\)](#)