

THIS DRAWING IS UNPUBLISHED. RELEASED FOR PUBLICATION
 © COPYRIGHT - By - ALL RIGHTS RESERVED.

LOC	DIST	REVISIONS			
P	LTR	DESCRIPTION	DATE	DWN	APVD
GP	00	AE7	REVISED PER ECO-15-006593	27APR2015	LL SH

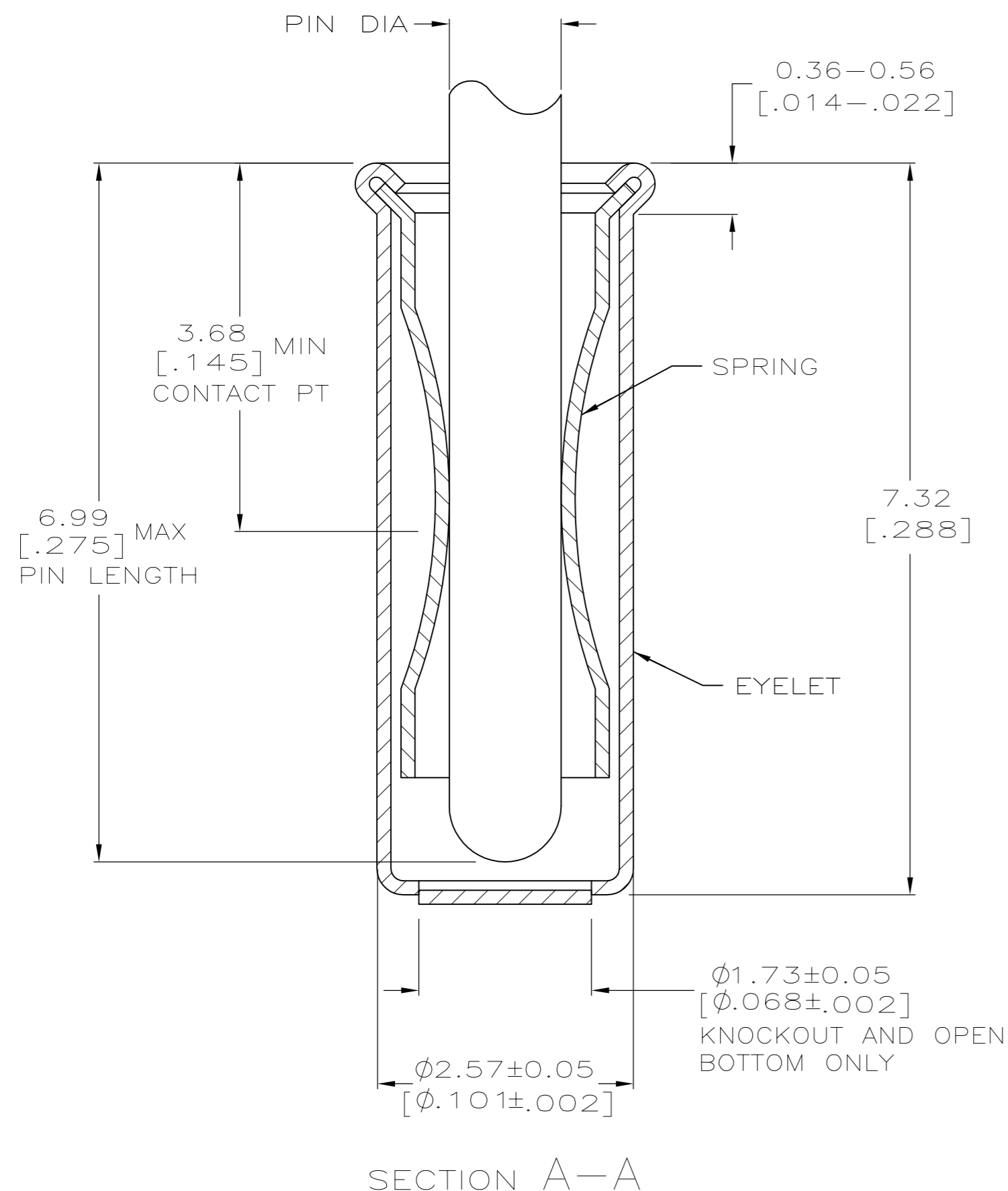
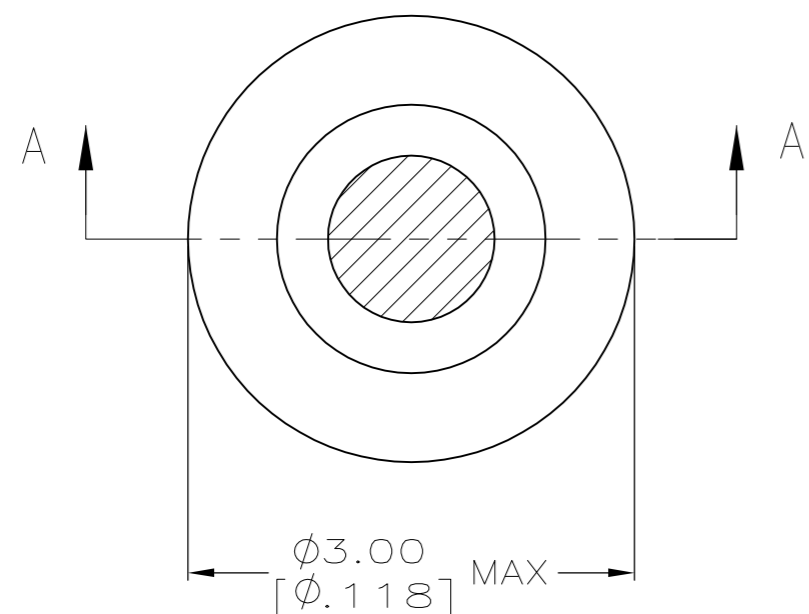

- 1. TIN PER MIL-T-10727 OR TIN LEAD .000254 [.000100] MIN THK.
- 2. GOLD PER MIL-G-45204, TYPE II, 0.00076 [.000030] MIN THK OVER NICKEL PER QQ-N-290 0.00028 [.000011] MIN THK ON CONTACT AREA.
- 3. GOLD FLASH PER MIL-G-45204, TYPE II, 0.13µm [.000005] MIN THK. OVER NICKEL PLATE PER QQ-N-290 0.51µm-1.52µm
- 4. RECOMMENDED HOLE SIZE, PLATED OR UNPLATED: m [.000020-.000060] EXT THK.
 MACHINE INSERTION: 2.56±0.08 [.101±.003]
 HAND INSERTION: 2.62^{+0.10}/_{-0.00} [.103^{+0.04}/_{-0.000}]
- 5. APPLICATION TOOL PART NUMBER:
 MACHINE NO. 682127-6
 INSERTION HEAD NO. 682039-5
- 6. TO INSURE PROPER SPRING TENSION DO NOT EXCEED A 0.05 [.002] DIFFERENCE IN PIN DIA WHEN CHANGING TO A SMALLER PIN.
- 7. BOTTOM PLUG KNOCKOUT TOOL PART NUMBER 69729 WITH TIP PART NUMBER 69728-3.
- 8. TIN PER ASTM B 545, 0.00254 [.000100] MIN THK.
- 9. MATERIAL: SPRING: BERYLLIUM COPPER, QQ-C-533.
 EYELET: COPPER, QQ-C-576.
- 10. PACKAGE: MAYLAR STRIP.

10						
	CLOSED	1.27-1.45 [.050-.057]	GOLD 3	GOLD 2		7-50871-3
	CLOSED	1.07-1.24 [.042-.049]	TIN 8	TIN 8		6-50871-8
	CLOSED	1.07-1.24 [.042-.049]	TIN 8	TIN 1		3-50871-0
SUPSD BY 1-50871-4	CLOSED	1.27-1.45 [.050-.057]			GOLD 2	2-50871-8
SUPSD BY 50871-5						2-50871-7
OBSOLETE						2-50871-6
OBSOLETE	KNOCKOUT		TIN 1	TIN 1		2-50871-5
OBSOLETE	OPEN					2-50871-4
OBSOLETE	CLOSED	1.42-1.65 [.056-.065]				2-50871-3
OBSOLETE	KNOCKOUT		GOLD 3		GOLD 2	2-50871-2
	OPEN		TIN 1			2-50871-1
OBSOLETE			TIN 1			1-50871-9
OBSOLETE	CLOSED	1.27-1.45 [.050-.057]	GOLD 3			1-50871-8
OBSOLETE			TIN 1	TIN 1		1-50871-7
	OPEN					1-50871-4
	CLOSED	1.27-1.45 [.050-.057]	GOLD 3	GOLD 2		1-50871-3
	OPEN					1-50871-0
	CLOSED		TIN 1	TIN 1		50871-8
	OPEN					50871-6
OBSOLETE	CLOSED	1.07-1.24 [.042-.049]				50871-5
	KNOCKOUT		GOLD 3		GOLD 2	50871-4
	OPEN		TIN 1			50871-3
OBSOLETE			GOLD 3			50871-1
						50871
	BOTTOM TYPE	RECOMMENDED PIN DIA 6	EYELET	SPRING		PART NO
			FINISH			

THIS DRAWING IS A CONTROLLED DOCUMENT. DWN R. TALLEY 20SEP05
 CHK R. MILLER 8-22-91

DIMENSIONS: mm [INCHES] TOLERANCES UNLESS OTHERWISE SPECIFIED:
 0 PLC ± -
 1 PLC ± -
 2 PLC ± 0.20 [.008]
 3 PLC ± -
 4 PLC ± -
 ANGLES ± -

MATERIAL FINISH

PRODUCT SPEC
 APPLICATION SPEC
 WEIGHT

SCALE 20:1 SHEET 1 of 1 REV AE7

STE TE Connectivity
 MINIATURE SPRING SOCKET ASSEMBLY
 SERIES 5

SIZE A2 CAGE CODE 00779 DRAWING NO C-50871 RESTRICTED TO

CUSTOMER DRAWING

单击下面可查看定价，库存，交付和生命周期等信息

[>>TE Connectivity\(泰科\)](#)