

EJECTION LATCHES OMITTED IN THIS VIEW FOR CLARITY

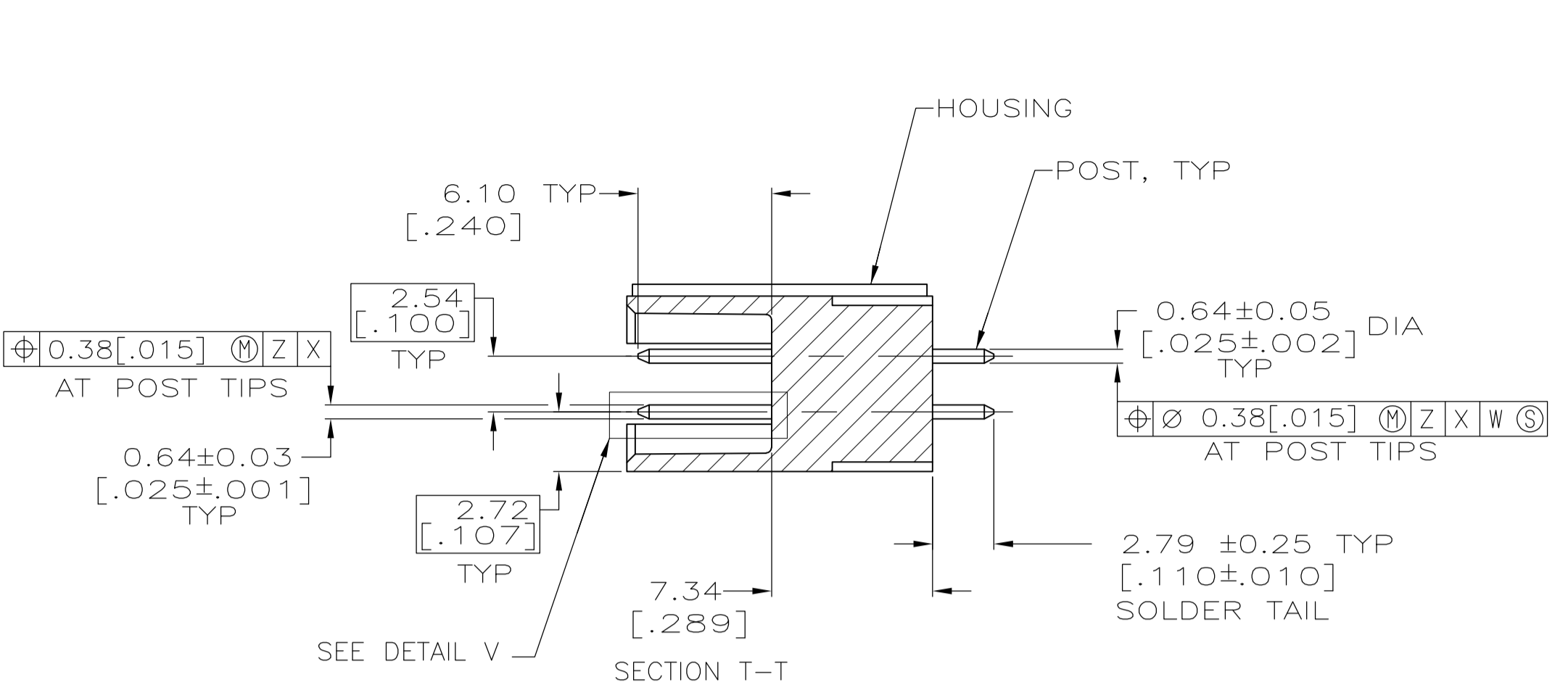

- 1. COORDINATE DIMENSION APPLIES FROM BASIC LOCATION.
- 2. 10 AND 14 POSITION SIZES CONTAIN ONLY ONE SLOT FOR SNAP-IN POLARIZER (MILITARY POLARIZATION) LOCATED AS SHOWN.
- 3. 10 POSITION SIZES CONTAIN ONLY ONE SLOT FOR DUAL POLARIZATION, LOCATED AS SHOWN.
- 4. RECOMMENDED PRINTED CIRCUIT BOARD THICKNESS IS 1.57 [.062].
- 5. DISTANCE REQUIRED BY EJECTION LATCHES IN THE OPEN POSITION.
- 6. POSTS:
GOLD FLASH OVER PALLADIUM-NICKEL PLATE, 0.38µm [.000015] MIN TOTAL ON THE LOCALIZED PLATE AREA,
2.54µm [.000100] MIN TIN-LEAD PLATE ON THE SOLDER-TAIL,
1.27µm [.000050] MIN NICKEL UNDERPLATE ON THE ENTIRE POST.
OR
0.38µm [.000015] MIN GOLD PLATE ON THE LOCALIZED PLATE AREA,
2.54µm [.000100] MIN TIN-LEAD PLATE ON THE SOLDER-TAIL,
1.27µm [.000050] MIN NICKEL UNDERPLATE ON THE ENTIRE POST.
- 7. MATERIAL:
HOUSING: GLASS FILLED NYLON OR POLYESTER, 94V-0 RATED, BLACK.
POSTS: PHOSPHOR BRONZE OR BRASS.

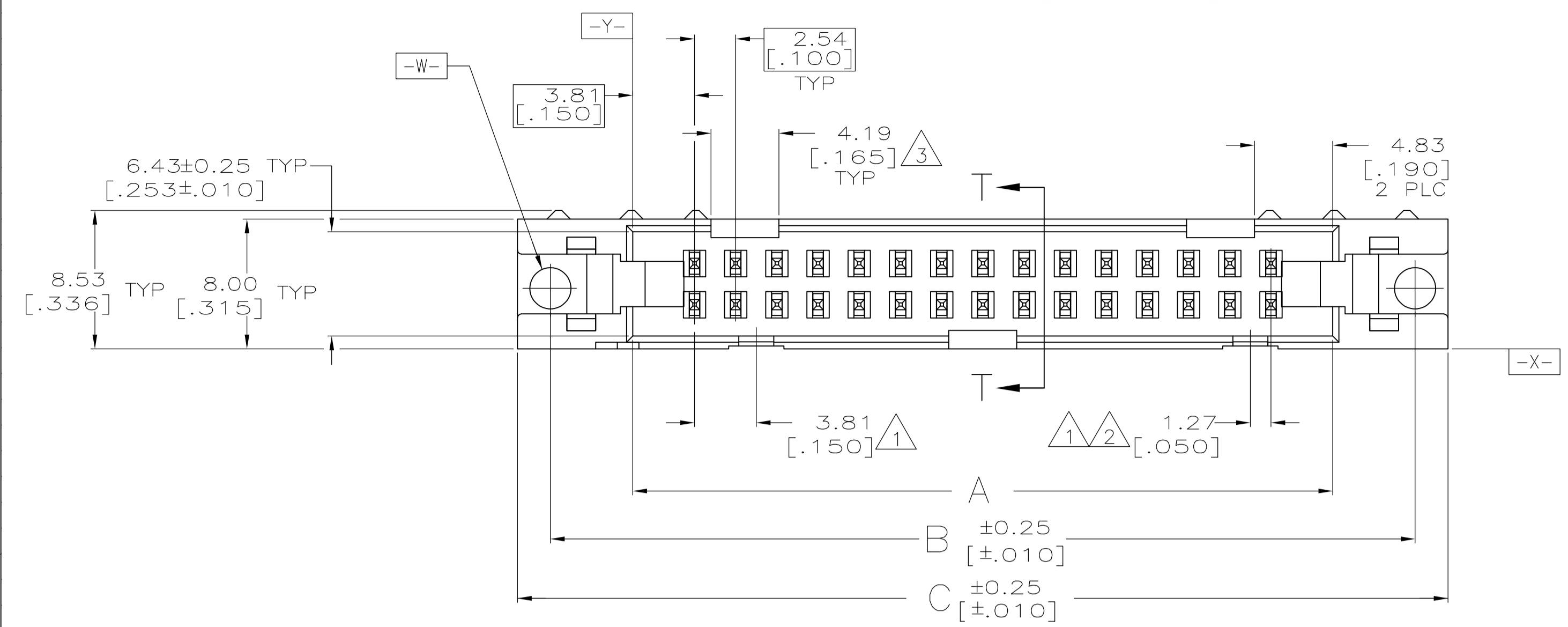
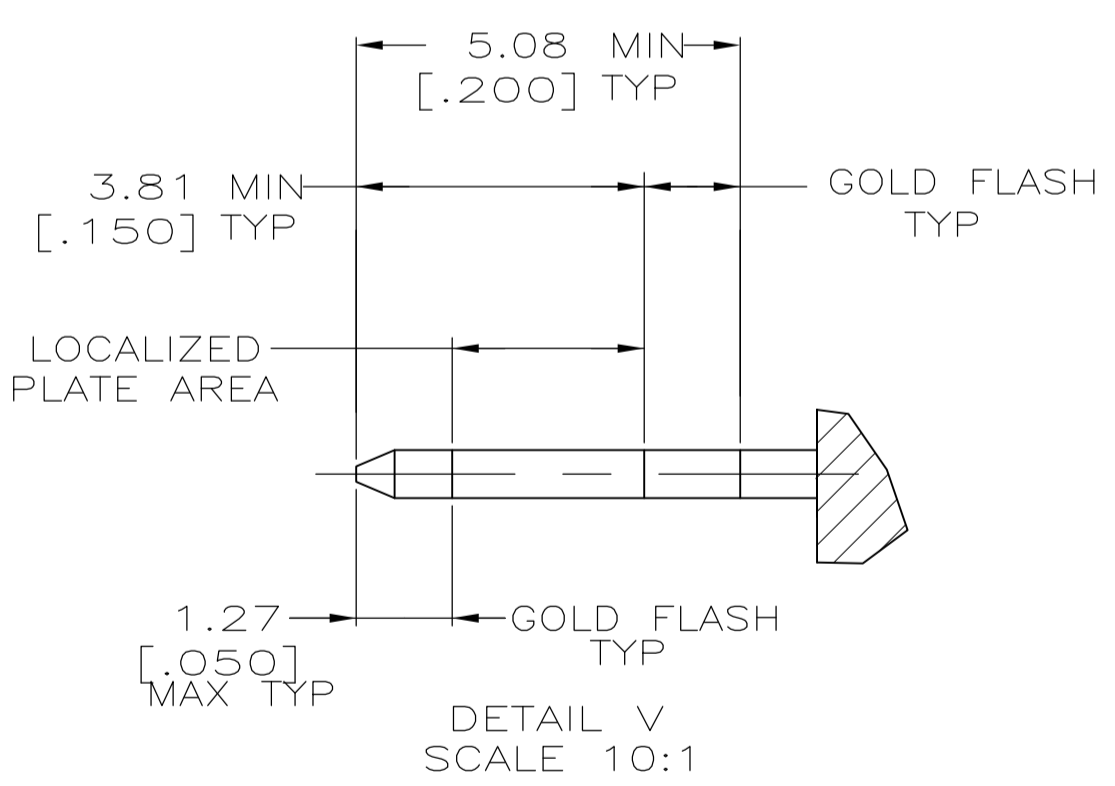
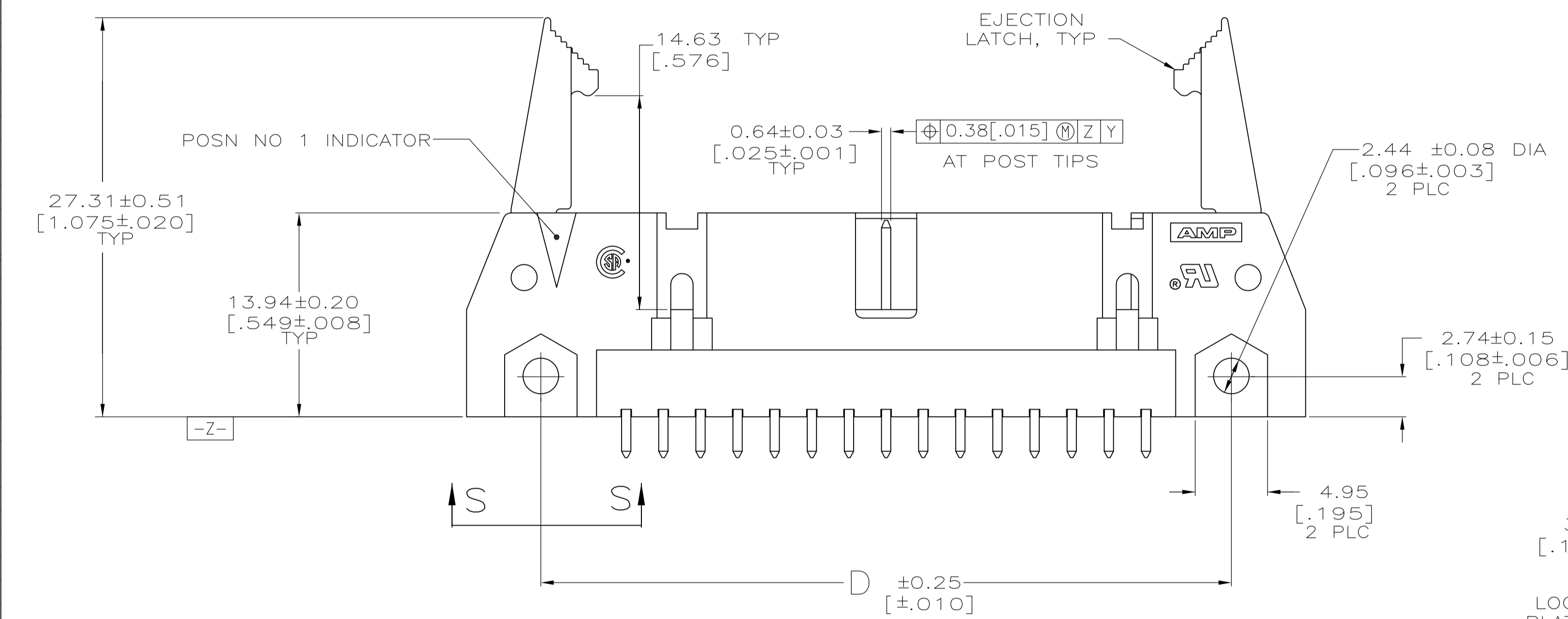

OBSELETE	53.34	71.12	65.02	75.18	71.12	60.96		
	[2.100]	[2.800]	[2.560]	[2.960]	[2.800]	[2.400]	44	1-499922-3
	78.74	96.52	90.42	100.58	96.52	86.36	64	1-499922-2
	[3.100]	[3.800]	[3.560]	[3.960]	[3.800]	[3.400]	60	1-499922-1
	73.66	91.44	85.34	95.50	91.44	81.28	50	1-499922-0
	[2.900]	[3.600]	[3.360]	[3.760]	[3.600]	[3.200]	40	499922-9
	60.96	78.74	72.64	82.80	78.74	68.58	34	499922-8
	[2.400]	[3.100]	[2.860]	[3.260]	[3.100]	[2.700]	30	499922-7
	48.26	66.04	59.94	70.10	66.04	55.88	26	499922-6
	[1.900]	[2.600]	[2.360]	[2.760]	[2.600]	[2.200]	24	499922-5
	40.64	58.42	52.32	62.48	58.42	48.26	20	499922-4
	[1.600]	[2.300]	[2.060]	[2.460]	[2.300]	[1.900]	16	499922-3
	35.56	53.34	47.24	57.40	53.34	43.18	14	499922-2
	[1.400]	[2.100]	[1.860]	[2.260]	[2.100]	[1.700]	10	499922-1
	30.48	48.26	42.16	52.32	48.26	38.10		
	[1.200]	[1.900]	[1.660]	[2.060]	[1.900]	[1.500]		
	27.94	45.72	39.62	49.78	45.72	35.56		
	[1.100]	[1.800]	[1.560]	[1.960]	[1.800]	[1.400]		
	22.86	40.64	34.54	44.70	40.64	30.48		
	[.900]	[1.600]	[1.360]	[1.760]	[1.600]	[1.200]		
	17.78	35.56	29.46	39.62	35.56	25.40		
	[.700]	[1.400]	[1.160]	[1.560]	[1.400]	[1.000]		
	15.24	33.02	26.92	37.08	33.02	22.86		
	[.600]	[1.300]	[1.060]	[1.460]	[1.300]	[.900]		
	10.16	27.94	21.84	32.00	27.94	17.78		
	[.400]	[1.100]	[.860]	[1.260]	[1.100]	[.700]		
	F	E	D	C	B	A	NO OF POSN	PART NUMBER

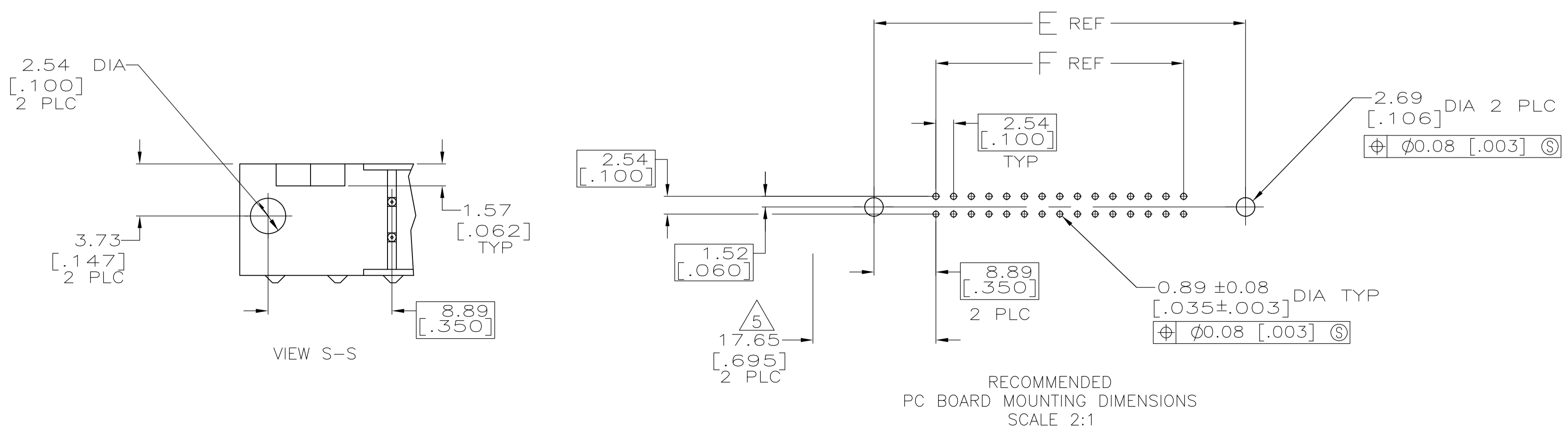

THIS DRAWING IS A CONTROLLED DOCUMENT.

DIMENSIONS: mm [INCHES]	TOLERANCES UNLESS OTHERWISE SPECIFIED:	DIN H. MOLL 4-23-90	STE TE Connectivity
0 PLC ± -	1 PLC ± -	11/28/90	NAME
2 PLC ± -	3 PLC ± 0.13[.005]		PRODUCT SPEC
4 PLC ± -	ANGLES ± -		108-40018
			APPLICATION SPEC
MATERIAL	FINISH	WEIGHT	SIZE CASE CODE DRAWING NO
		A1	00779 499922
		CUSTOMER DRAWING	RESTRICTED TO
		SCALE 4:1	SHEET 1 OF 1 REV H1

单击下面可查看定价，库存，交付和生命周期等信息

[>>TE Connectivity\(泰科\)](#)